



US00D411140S

United States Patent [19]

[11] Patent Number: Des. 411,140

Meryman et al.

[45] Date of Patent: ** Jun. 22, 1999

[54] TRUCK BODY

[75] Inventors: Roy L. Meryman, Renton; Wayne K. Simons, Kent, both of Wash.

[73] Assignee: PACCAR Inc, Bellevue, Wash.

[**] Term: 14 Years

[21] Appl. No.: 29/053,898

[22] Filed: May 1, 1996

[51] LOC (6) Cl. 12-08

[52] U.S. Cl. D12/96

[58] Field of Search D12/96, 97; 296/190; 180/89.1, 89.11, 89.12

[56] References Cited

U.S. PATENT DOCUMENTS

D. 312,805	12/1990	Marlowe et al.	D12/96
D. 320,583	10/1991	Simons et al.	D12/96
D. 328,273	7/1992	Kerney et al.	D12/96
D. 366,638	1/1996	Tucker et al.	D12/173
5,308,134	5/1994	Stanesu	296/91

OTHER PUBLICATIONS

- “Kenworth’s T600: Ten Years of Innovation”, Kenworth Truck Company brochure, Kirkland, WA (Jun. 1995).
- “Kenworth T600”, Kenworth Truck Company brochure, Kirkland WA.
- “Kenworth T600A, The Conventional Made Extraordinary”, Kenworth Truck Company Brochure, Kirkland, WA.
- “Kenworth T800”, Kenworth Truck Company brochure, Kirkland, WA.
- “Kenworth T800B”, Kenworth Truck Company brochure, Kirkland, WA.
- “Kenworth W900”, Kenworth Truck Company brochure, Kirkland, WA.
- “Kenworth W900L Aerocab”, Kenworth Truck Company brochure, Kirkland, WA.
- “Kenworth Construction Trucks”, Canadian Kenworth Truck Company brochure, Mississauga, Ontario.
- “Kenworth Aerocab”, Kenworth Truck Company brochure, Kirkland, WA.

- “Last Year, One Idea Changed A Lot of Attitudes About Driver Retention—Aerocab”, Kenworth Truck Company brochure, Kirkland, WA.
- “Kenworth Studio Sleeper”, Kenworth Truck Company brochure, Kirkland, WA.
- “Kenworth The World’s Best.”, Kenworth Truck Company brochure, Kirkland, WA.
- “Kenworth: Historical Background”, Kenworth Truck Company brochure, Kirkland, WA.
- “Kenworth K100E”, Canadian Kenworth Truck Company brochure, Mississauga, Ontario.
- “Kenworth T300”, Kenworth Truck Company brochure, Kirkland, WA.
- “Kenworth T400B T450B”, Kenworth Truck Company brochure, Kirkland, WA.
- “Kenworth C500B The Ultimate Survivor”, Kenworth Truck Company brochure, Kirkland, WA.

Primary Examiner—Melody N. Brown
Attorney, Agent, or Firm—Wells, St. John, Roberts, Gregory & Matkin, P.S.

[57] CLAIM

We claim the ornamental design for a truck body, as shown and described.

DESCRIPTION

FIG. 1 is a side elevational view of a truck body according to the invention. The opposite side elevational view is a mirror image of the view shown in FIG. 1.

FIG. 2 is a front view of the truck body of FIG. 1.

FIG. 3 top view of the truck body of FIG. 1; and, FIG. 4 is a rear elevational view of the truck body of FIG. 1.

The truck portions shown in broken lines in FIGS. 1–4 are for illustrative purposes only and form no part of the claimed design.

All embodiments show an optional sun visor over the windshield which can be omitted.

All embodiments, show optional side fairings along the rear edges of the cab sleeper compartments which can optionally be omitted.

1 Claim, 4 Drawing Sheets

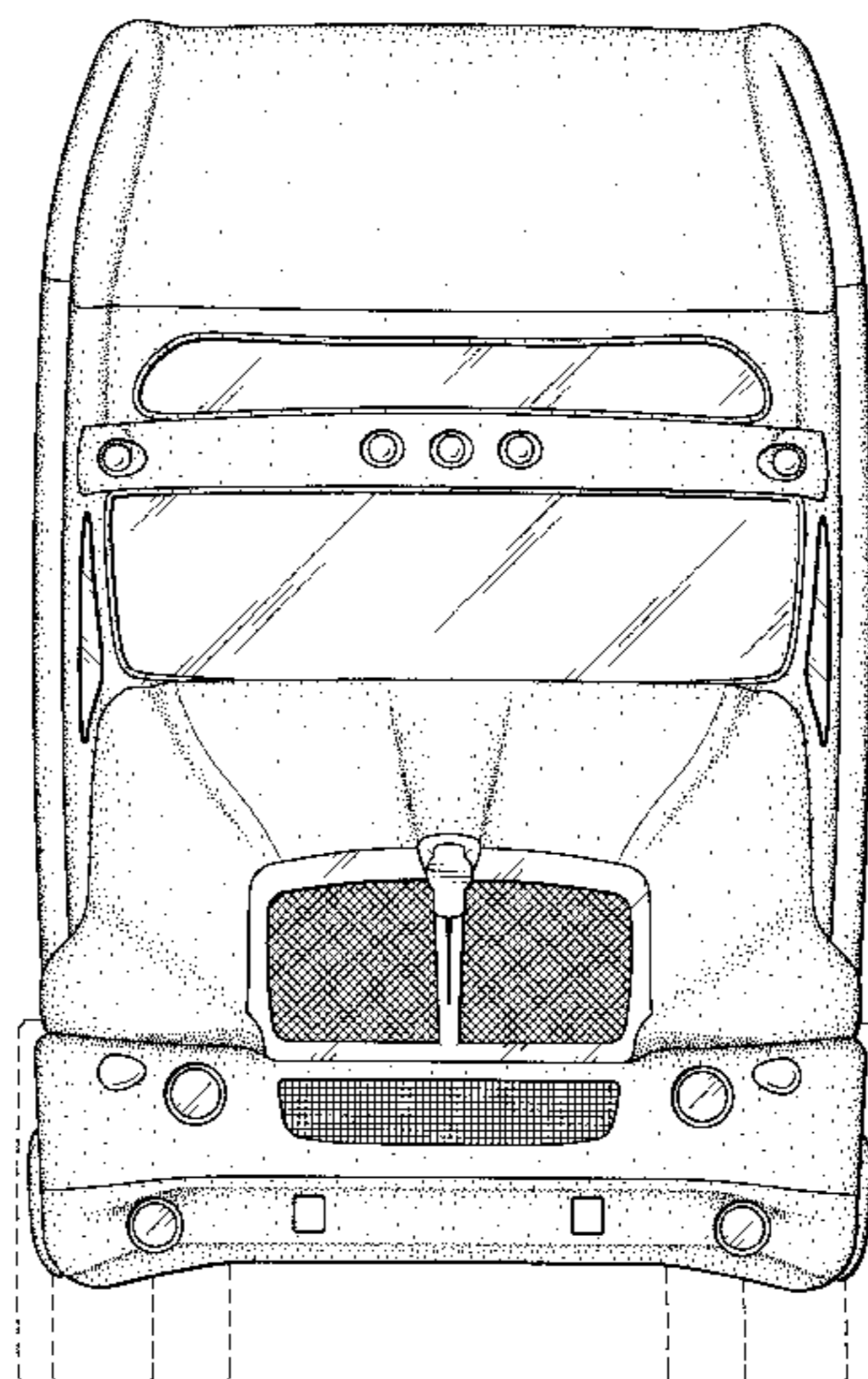

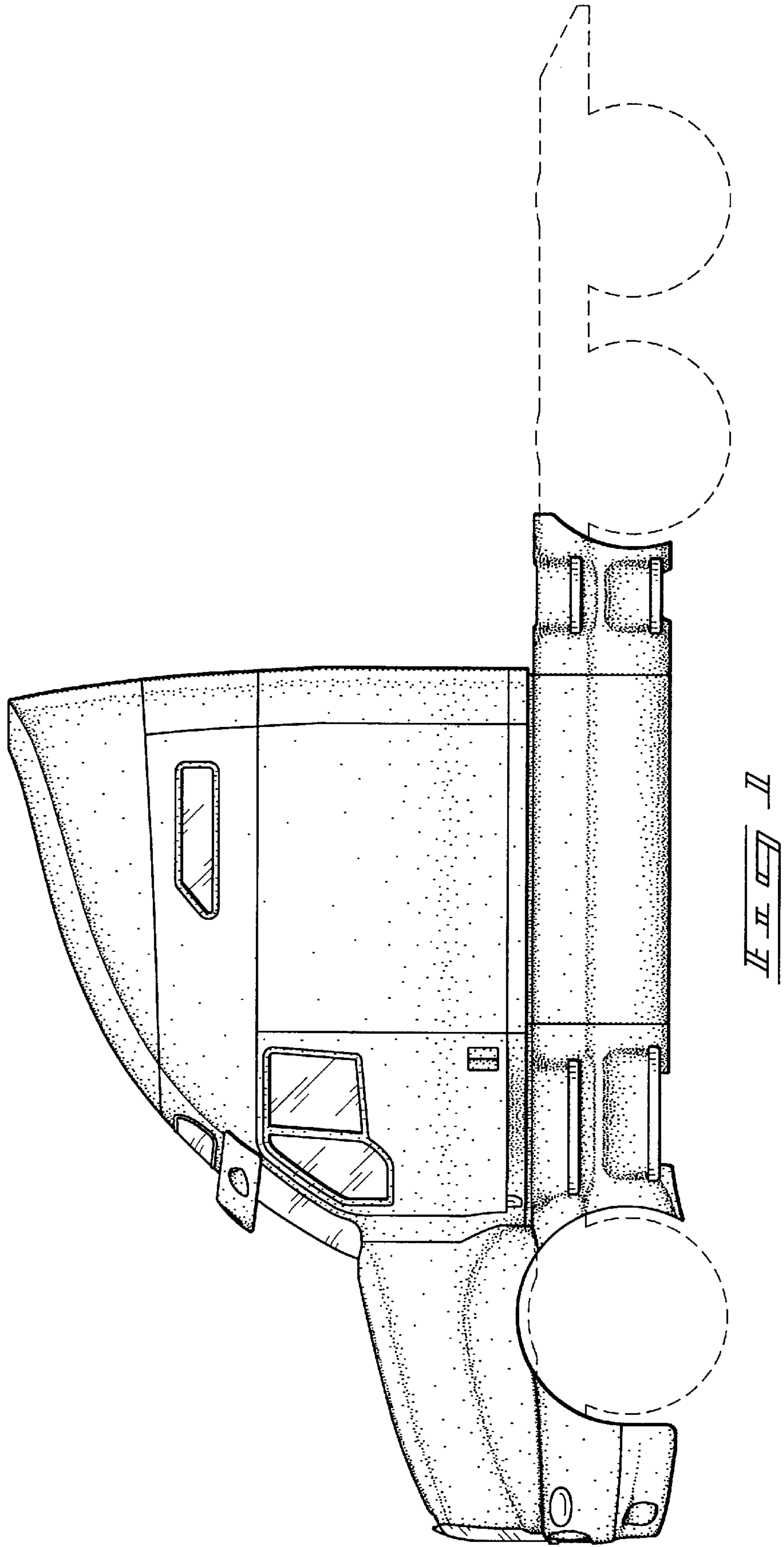

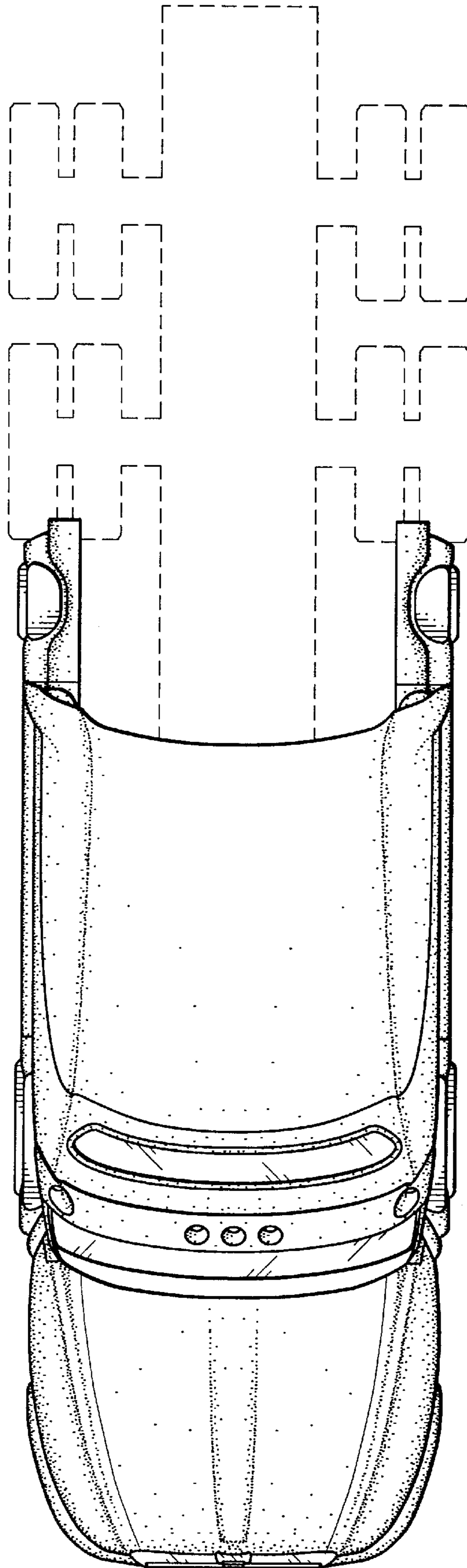

FIG. 2

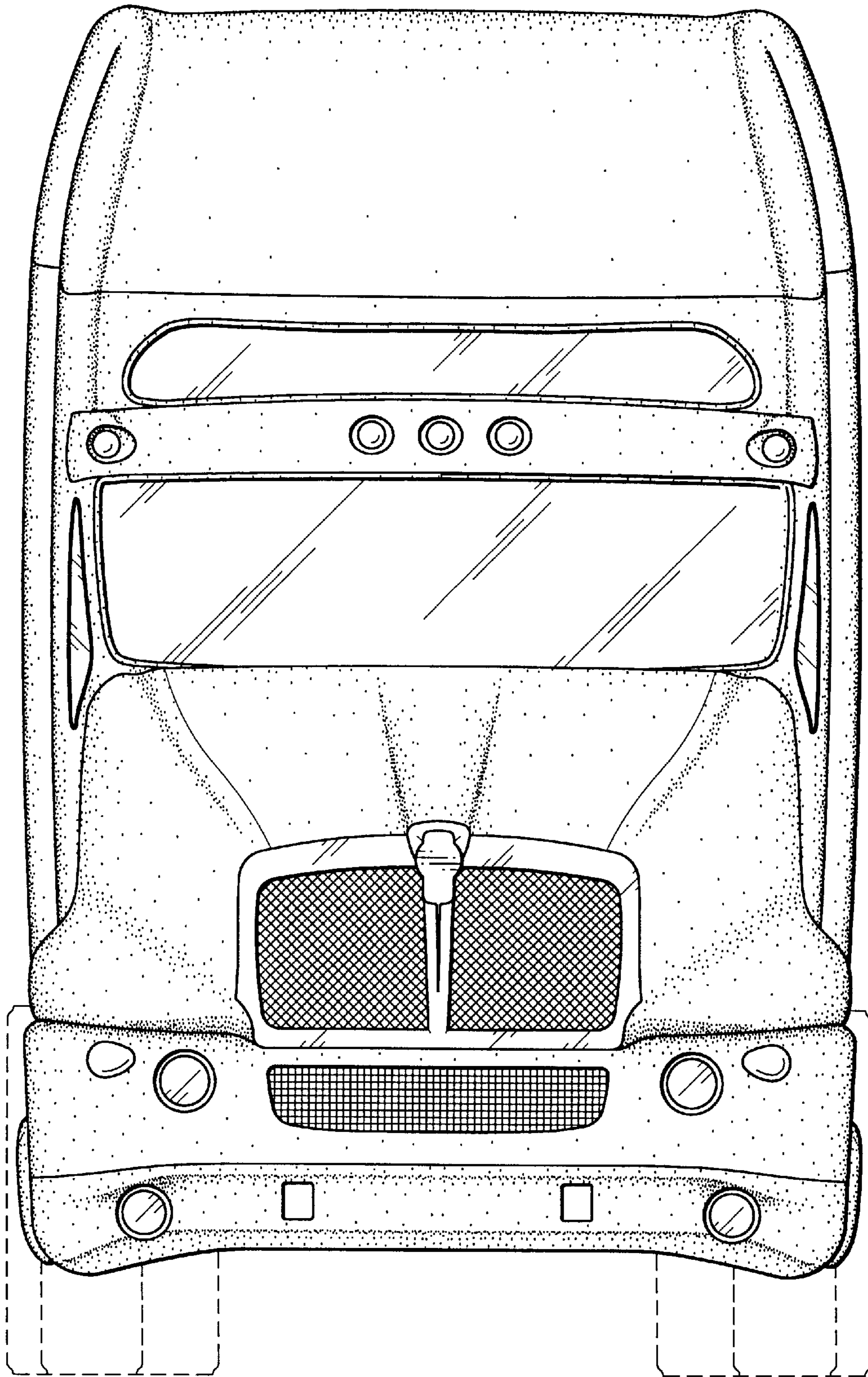

Fig. 3

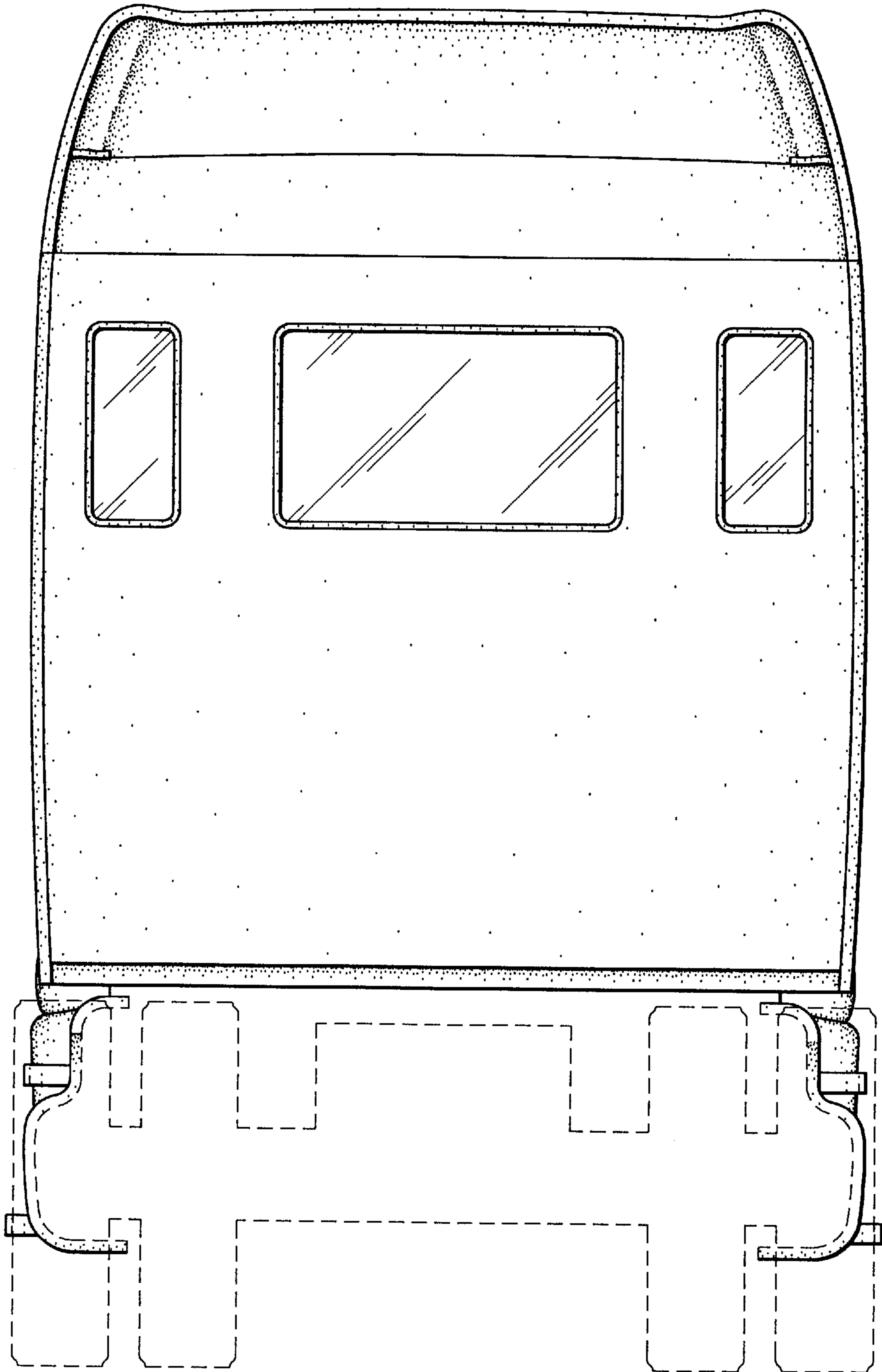

FIG. 4