



US00D411110S

United States Patent [19]
Kangas

[11] **Patent Number: Des. 411,110**
[45] **Date of Patent: ** Jun. 15, 1999**

[54] **HIBOY ROADSTER MAILBOX**
[76] Inventor: **Lloyd Alan Kangas**, 801 W. Amity Rd., Boise, Id. 83705
[**] Term: **14 Years**
[21] Appl. No.: **29/096,205**
[22] Filed: **Nov. 6, 1998**
[51] **LOC (6) Cl. 99-00**
[52] **U.S. Cl. D99/30; D99/42**
[58] **Field of Search D99/28, 29, 30, D99/37, 42; D21/424, 427, 433, 548, 549, 551; 232/19, 17, 20, 27, 33, 39; 446/8, 9, 10**

D. 371,888 7/1996 Tingler .
D. 383,503 9/1997 Pierce D21/549

OTHER PUBLICATIONS

Smithsonian Magazine p. 189 (Train Bottom), Nov. 1989.

Primary Examiner—Paula A. Mortimer
Attorney, Agent, or Firm—Charles R. Clark

[57] **CLAIM**

The ornamental design for a hiboy roadster mailbox, as shown and described.

DESCRIPTION

FIG. 1 is a left side elevational view of a hiboy roadster mailbox showing my new design, the right side being essentially the same without the mail signal flag;
FIG. 2 is a front elevational view thereof;
FIG. 3 is a top plan view thereof;
FIG. 4 is a rear elevational view thereof; and,
FIG. 5 is a bottom plan view thereof.

[56] **References Cited**
U.S. PATENT DOCUMENTS
D. 236,017 7/1975 Pekka D21/426
D. 248,580 7/1978 Luttrell .
D. 346,266 4/1994 Tingler .
D. 347,927 6/1994 Martin .

1 Claim, 1 Drawing Sheet

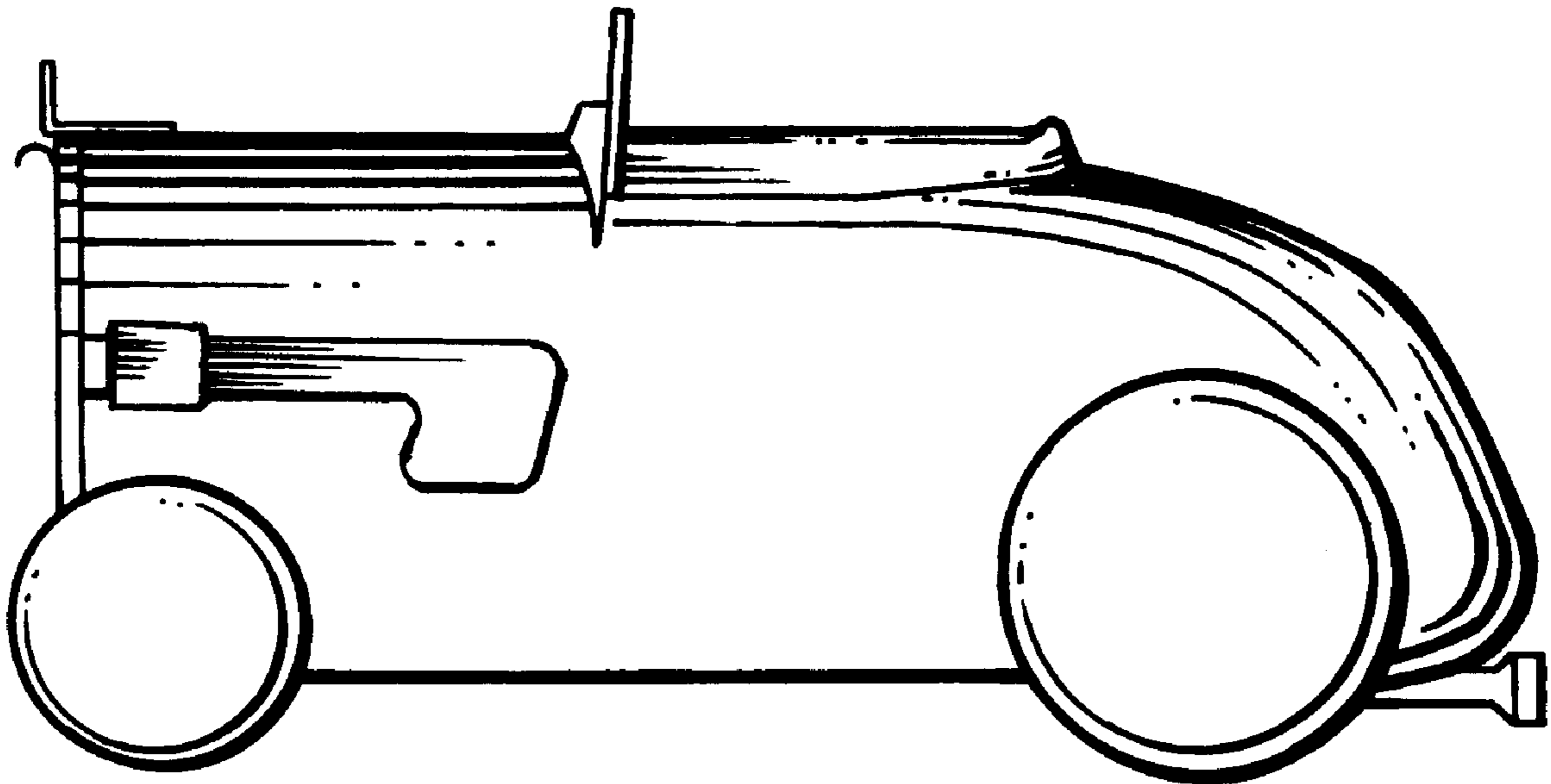

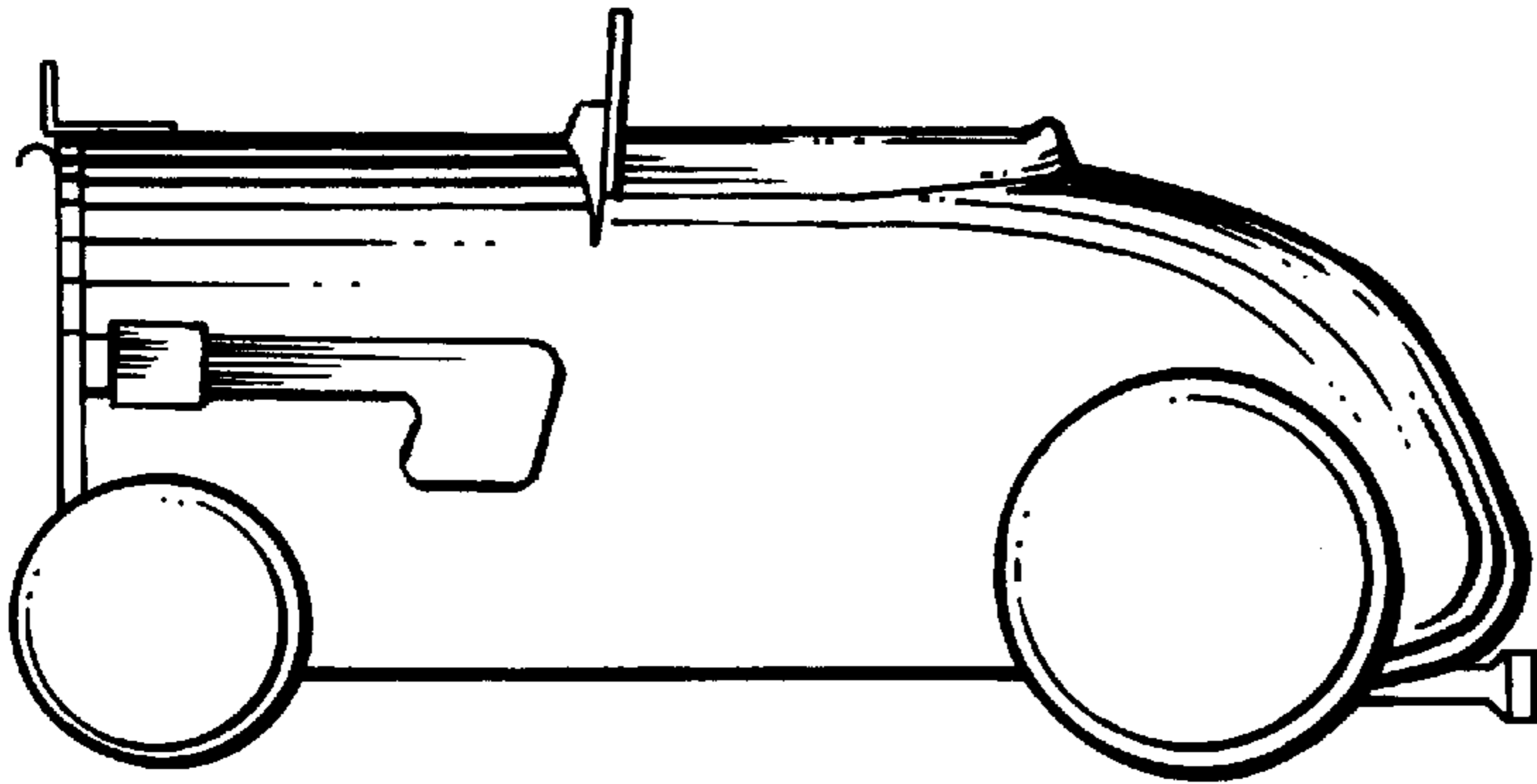

FIG. 1

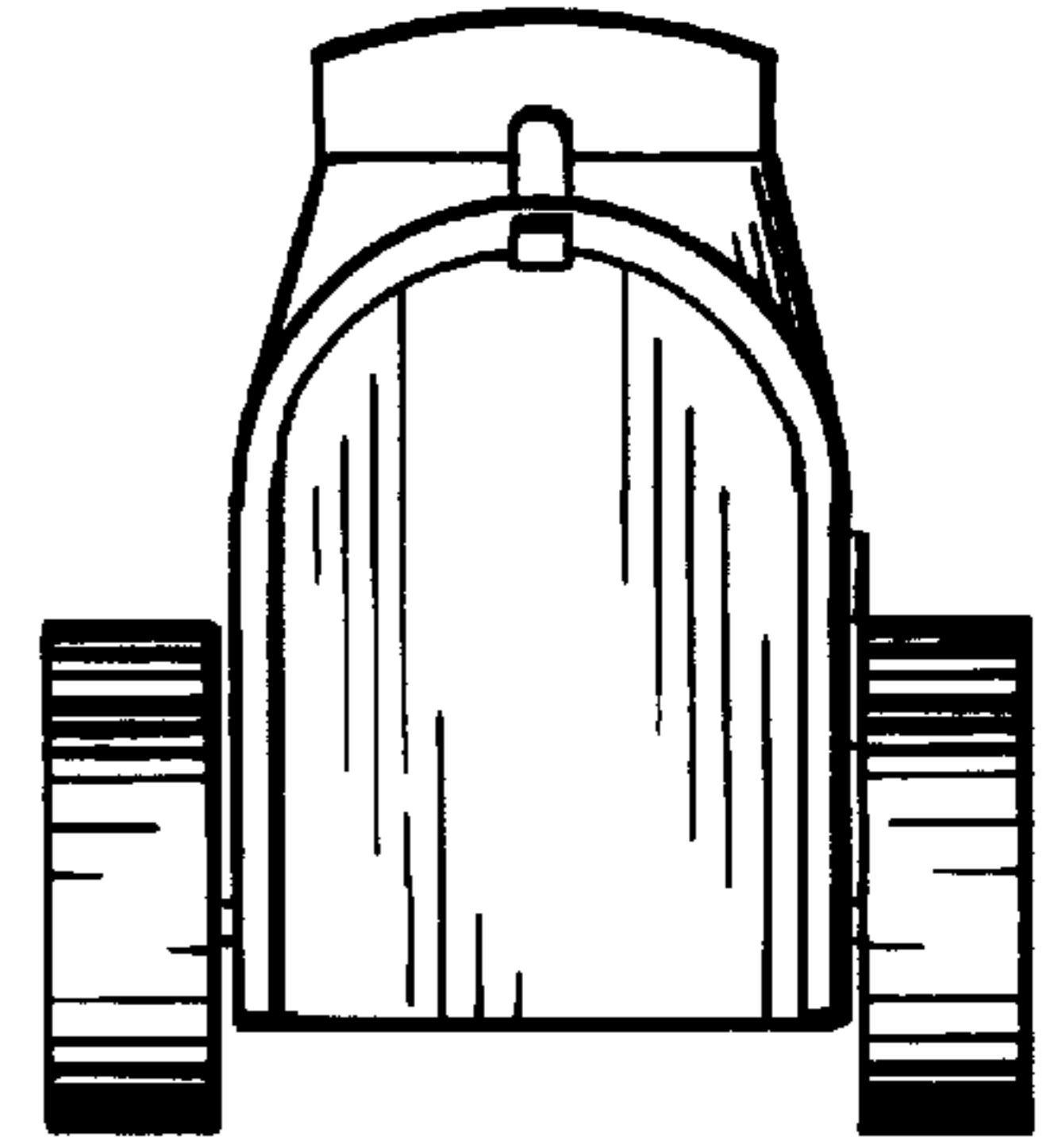

FIG. 2

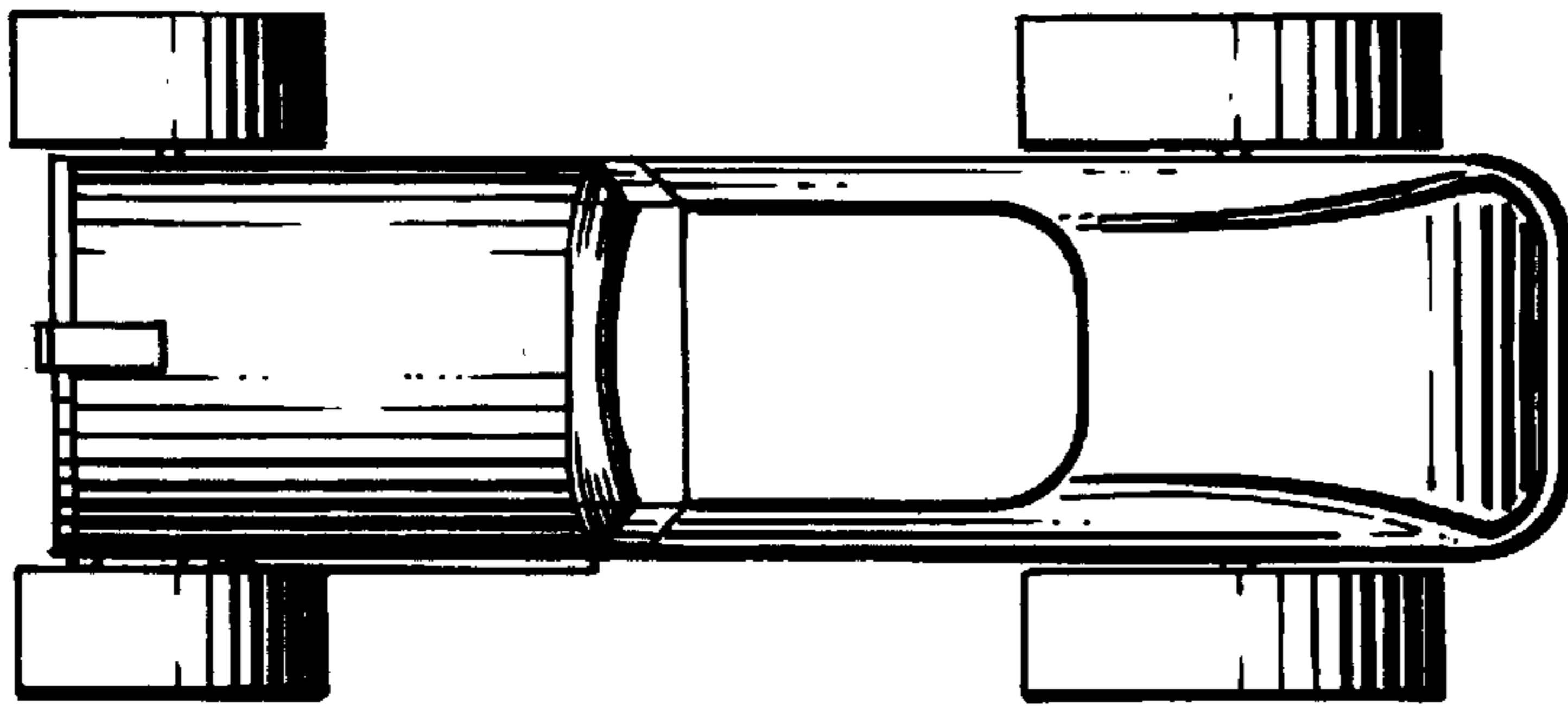

FIG. 3

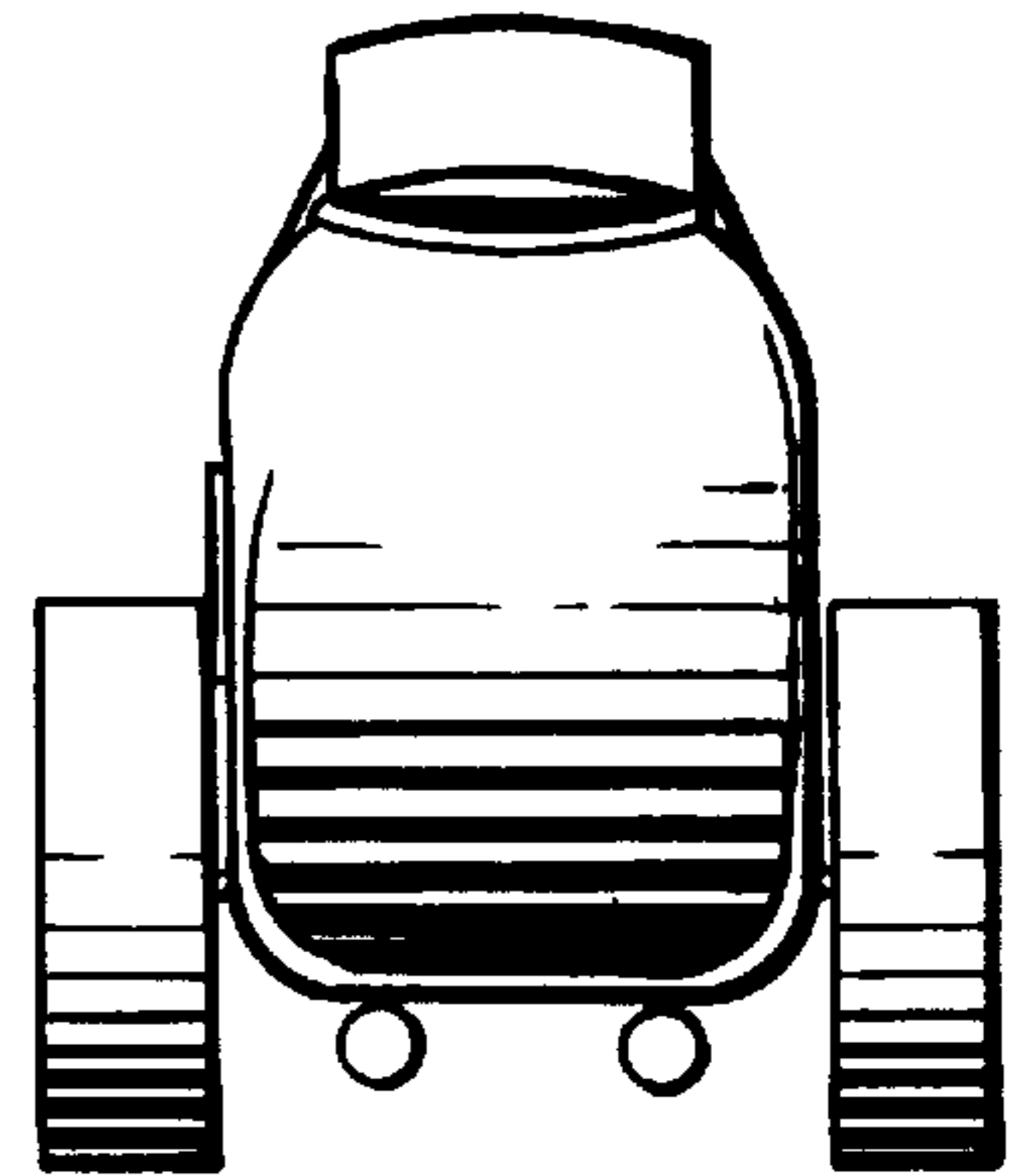

FIG. 4

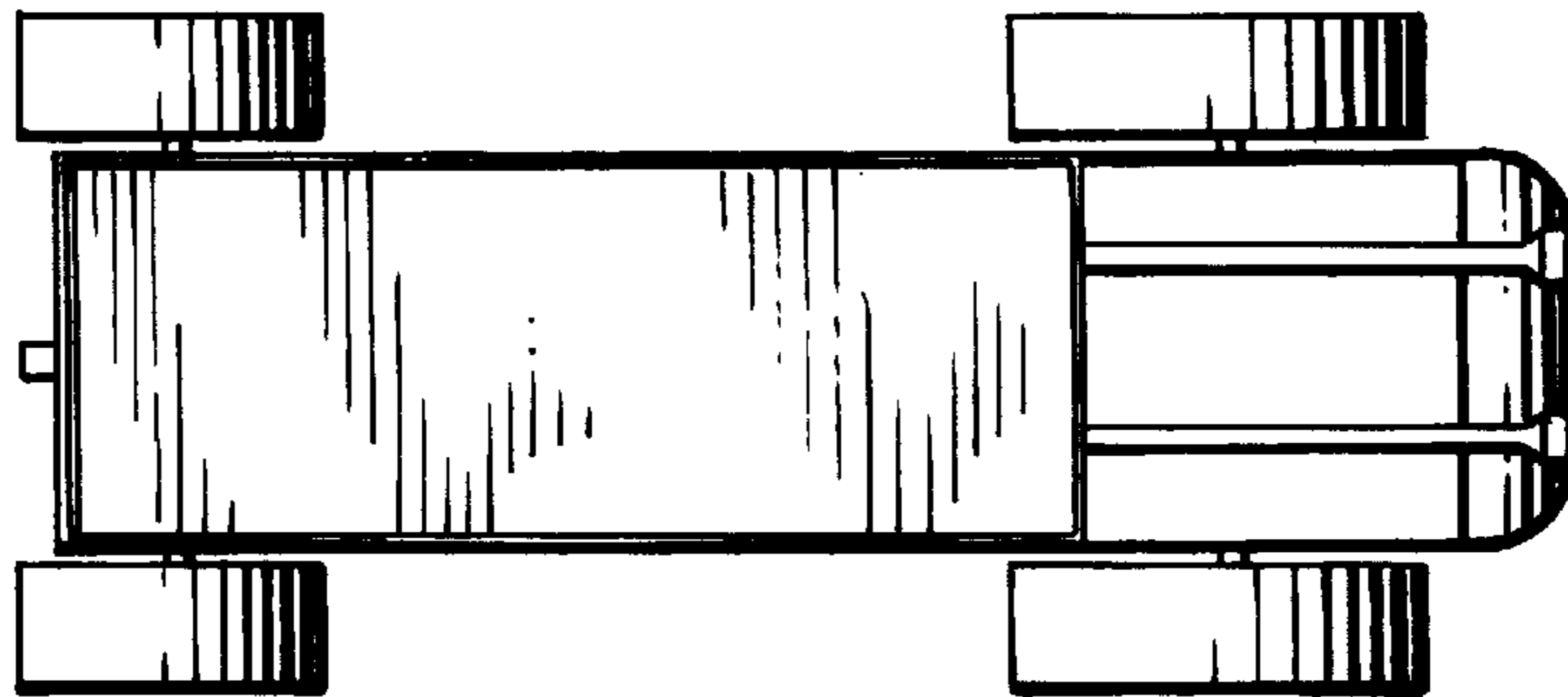

FIG. 5