



US00D411043S

United States Patent [19]

Wachler et al.

[11] **Patent Number: Des. 411,043**

[45] **Date of Patent: ** Jun. 15, 1999**

[54] **ICE SCRAPER**

4,040,140 8/1977 Hopkins et al. 15/236.01
4,164,801 8/1979 Thomas 15/236.01

[76] Inventors: **Lori Thomas Wachler**, 26524 Hendrie,
Huntington Woods, Mich. 48070;
Arthur Kleinpell, 2565 Kent Ridge Ct.,
Bloomfield Township, Mich. 48301

Primary Examiner—Susan J. Lucas
Assistant Examiner—Cynthia Ramirez
Attorney, Agent, or Firm—Kohn & Associates

[**] Term: **14 Years**

[57] **CLAIM**

[21] Appl. No.: **29/092,310**

The ornamental design for an ice scraper, as shown and described.

[22] Filed: **Aug. 17, 1998**

DESCRIPTION

[51] **LOC (6) Cl.** **08-05**

FIG. 1 is a front perspective view for an ice scraper showing our new design;

[52] **U.S. Cl.** **D32/43; D32/49**

FIG. 2 is a front elevational view;

[58] **Field of Search** D32/42, 46, 49,

FIG. 3 is a rear elevational view;

D32/43; 15/236.01, 236.02, 104.16, 105;
30/169, 170

FIG. 4 is a first side elevational view;

FIG. 5 is a second side elevational view;

FIG. 6 is a bottom plan view;

FIG. 7 is a top plan view; and,

FIG. 8 is a front plan view including a specific car design.

The broken line showing of a car in FIGS. 1 through 6 is for illustrative purposes only and forms no part of the claimed design.

[56] **References Cited**

U.S. PATENT DOCUMENTS

- D. 266,476 10/1982 Thomasson .
- D. 372,349 7/1996 Adair D32/49
- D. 374,525 10/1996 Kleinpell, II et al. D32/43
- D. 392,784 3/1998 Hellinger et al. D32/49
- D. 394,923 6/1998 Hellinger et al. D32/49

1 Claim, 2 Drawing Sheets

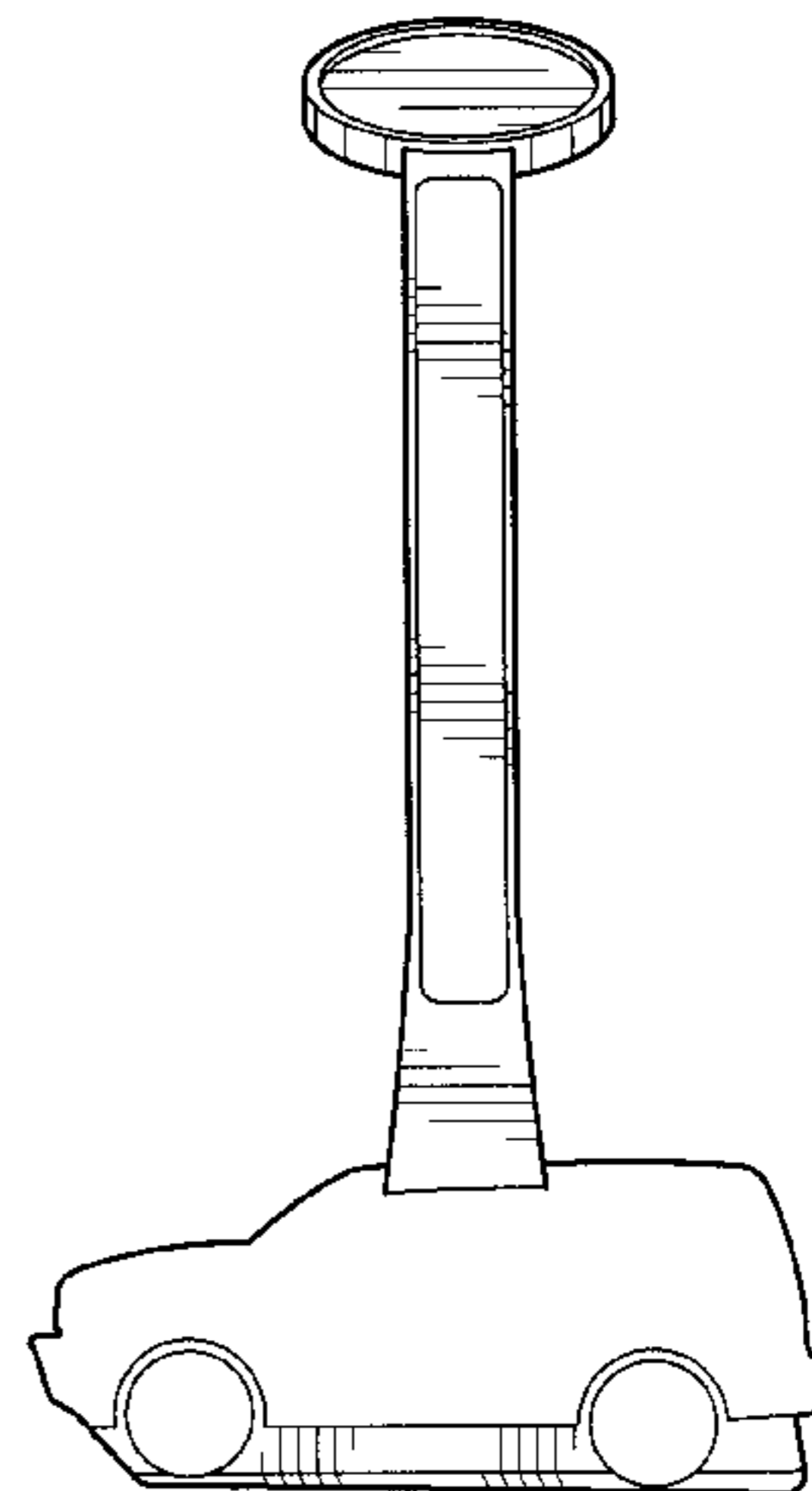
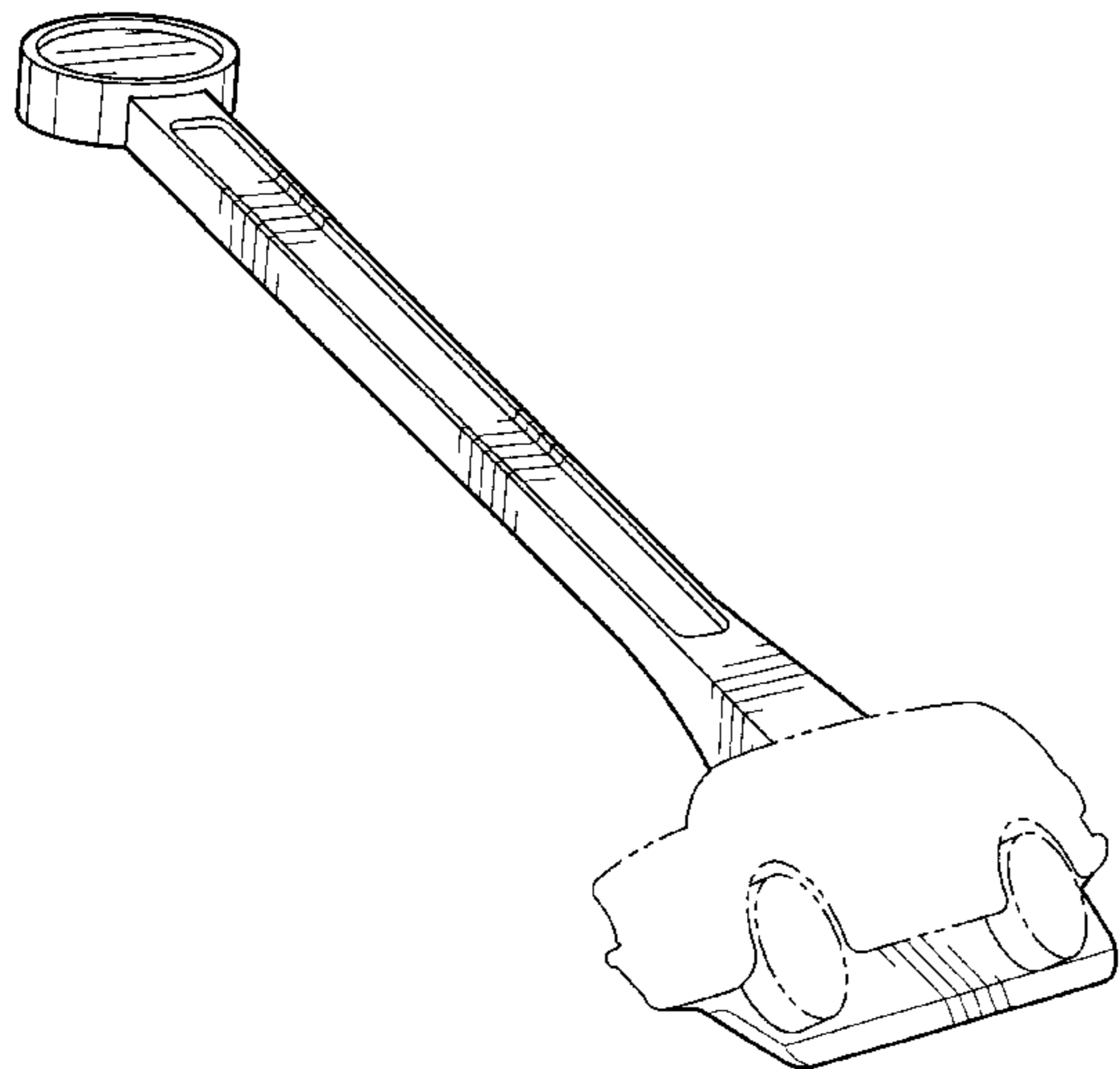

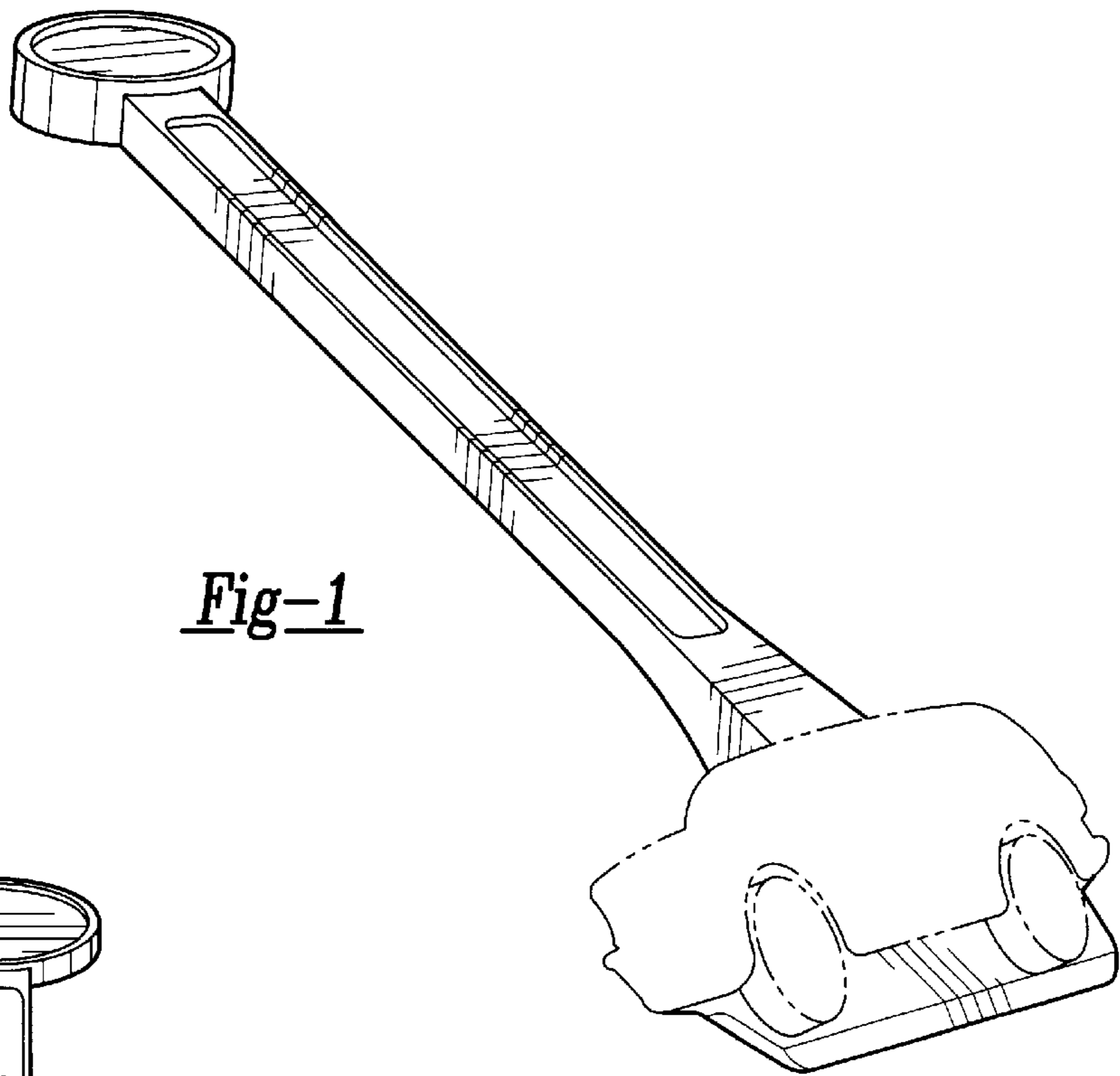

Fig-1

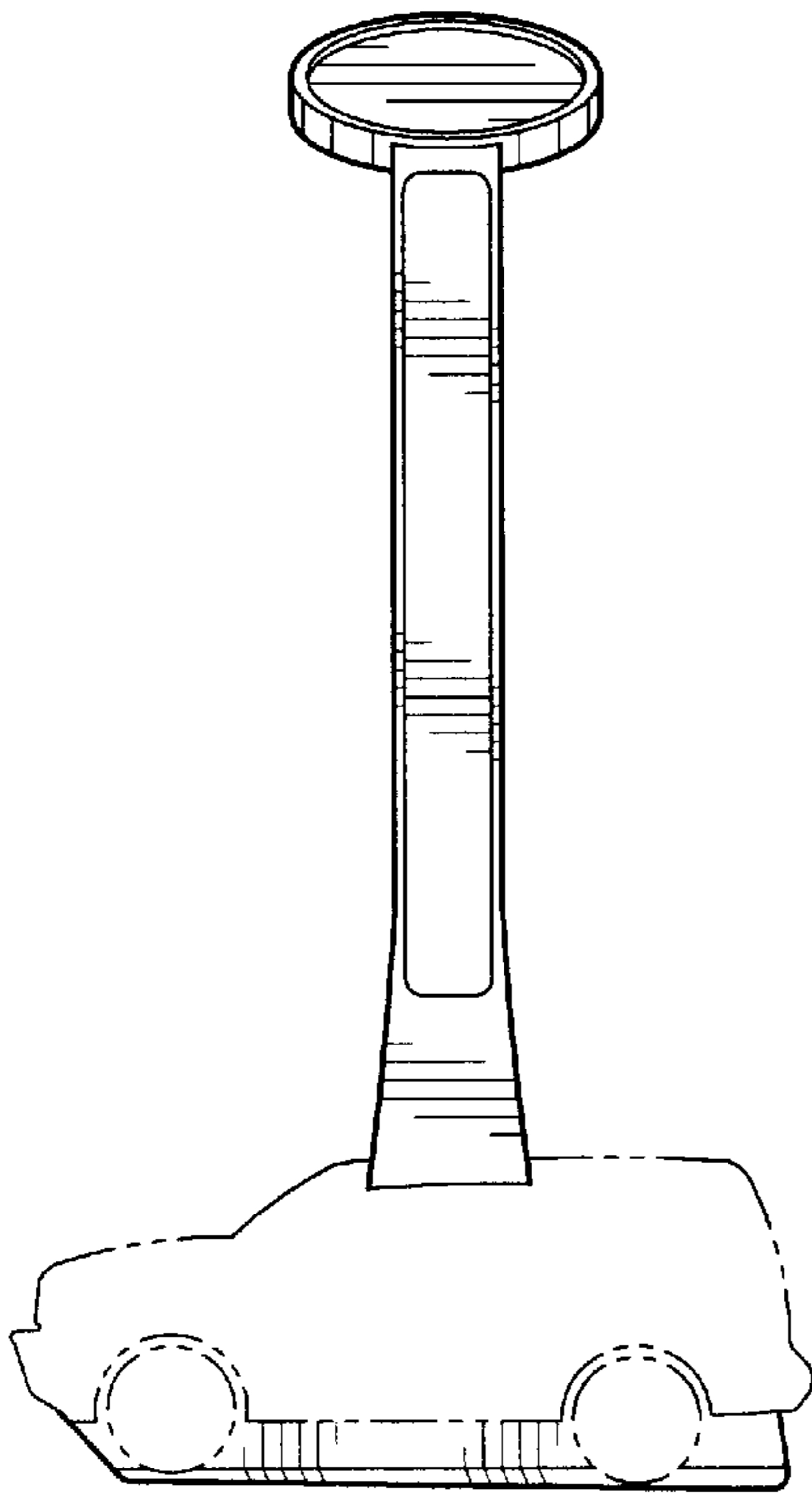

Fig-2

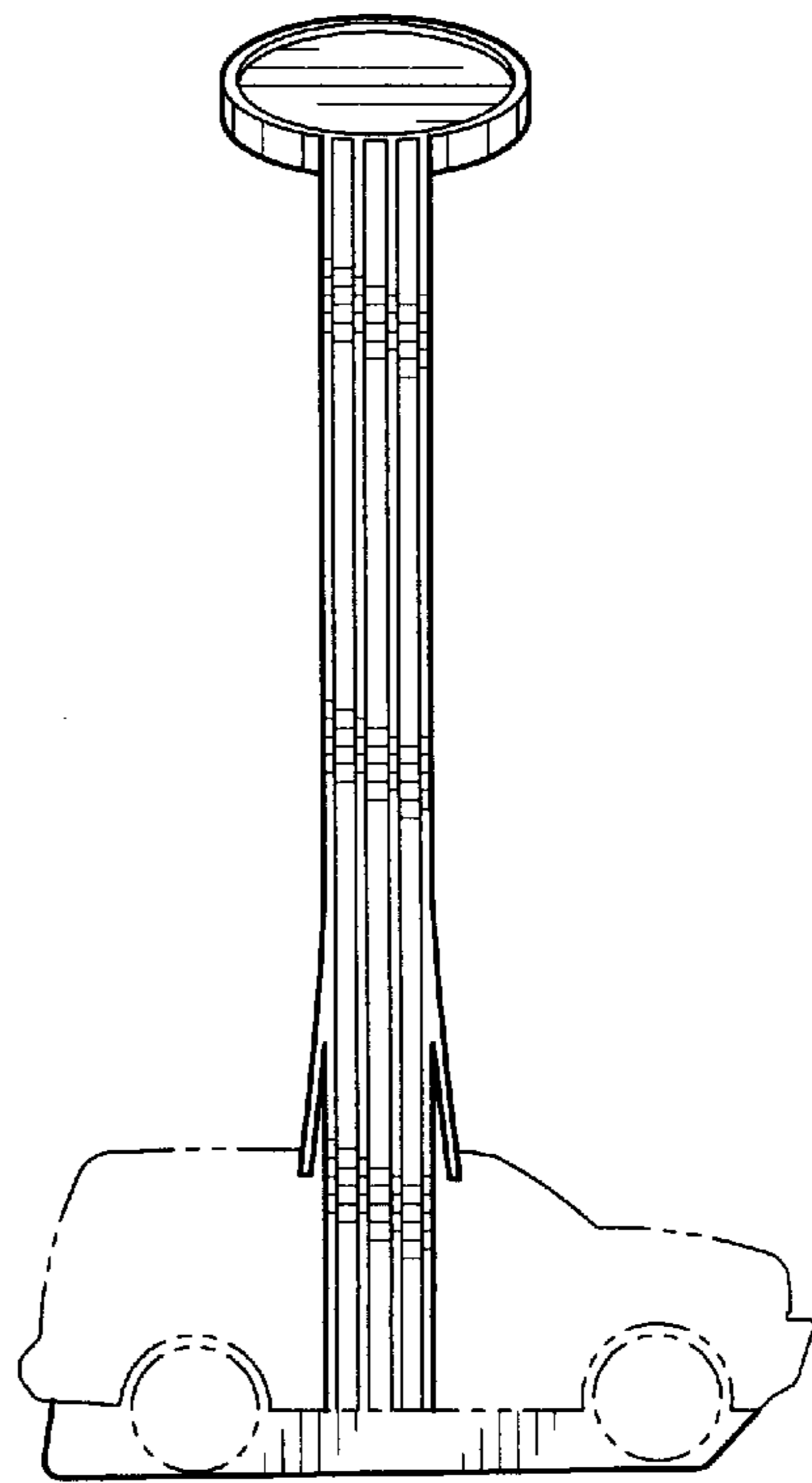

Fig-3



Fig-4

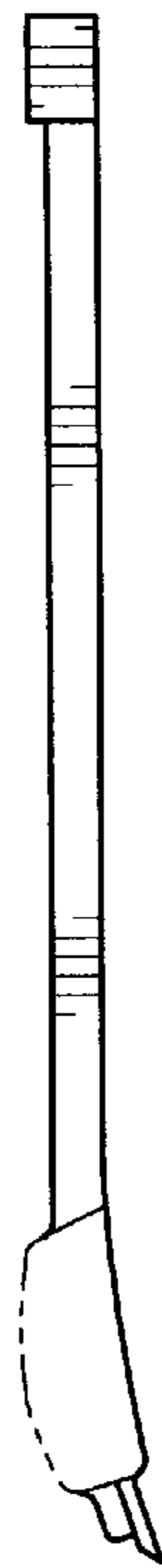

Fig-5

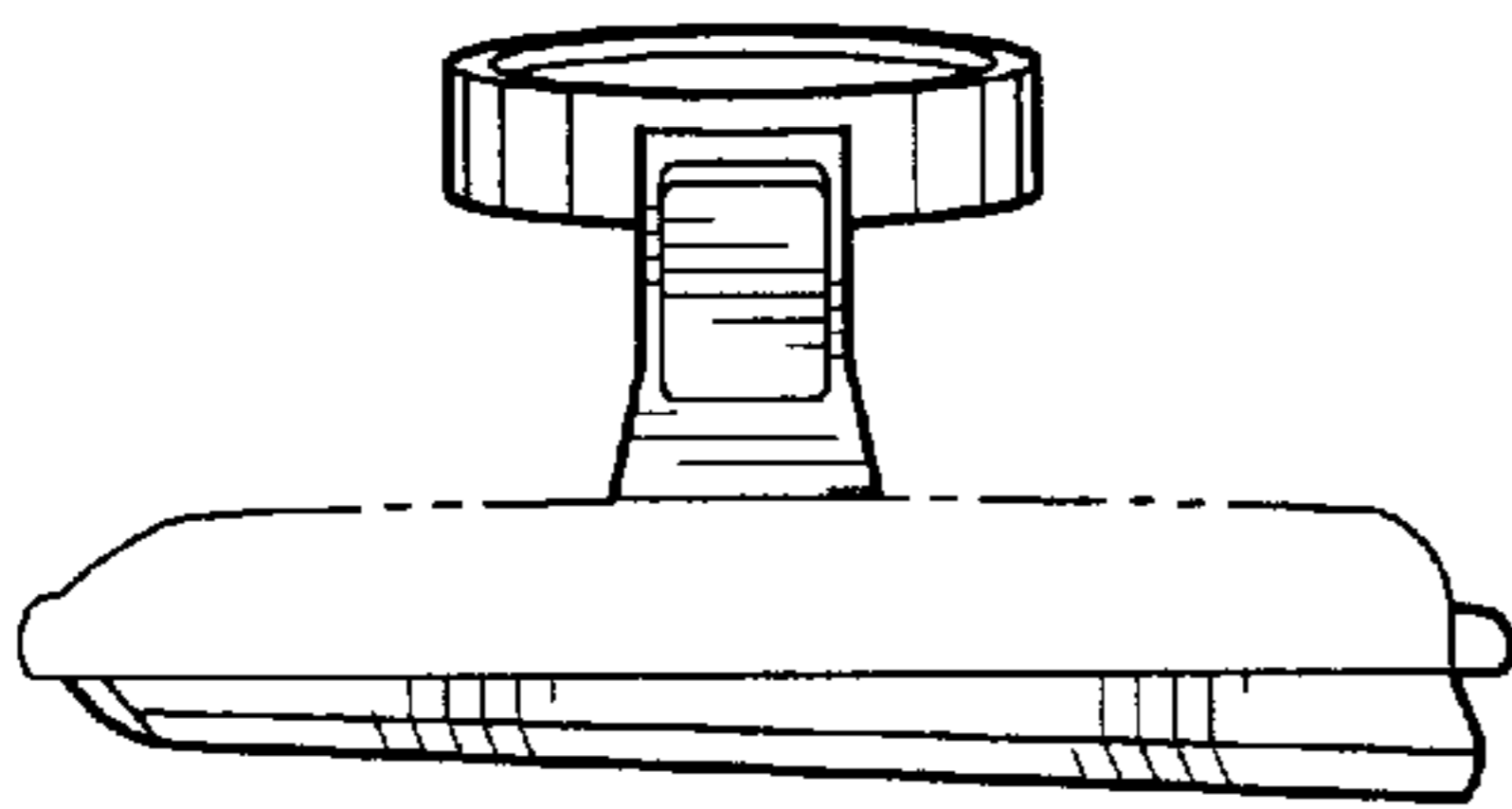

Fig-6

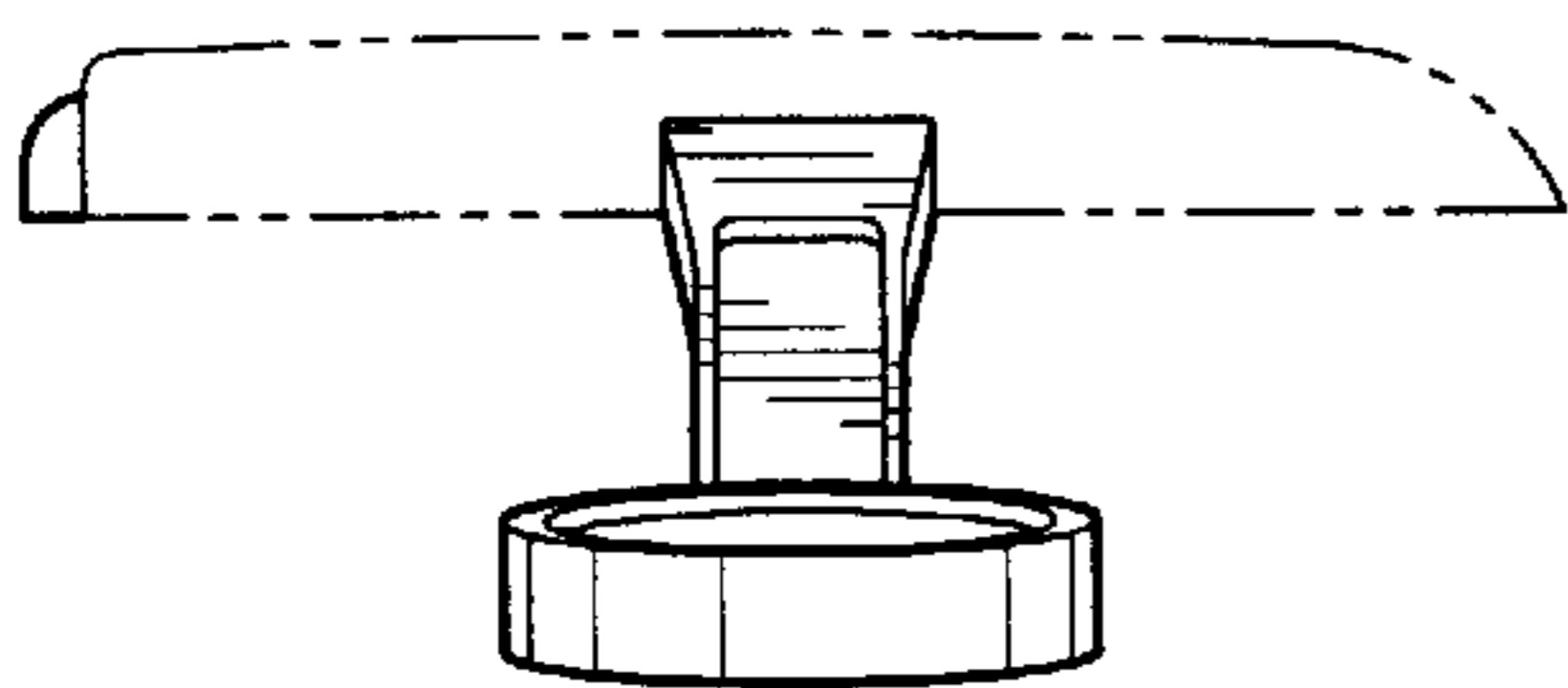

Fig-7

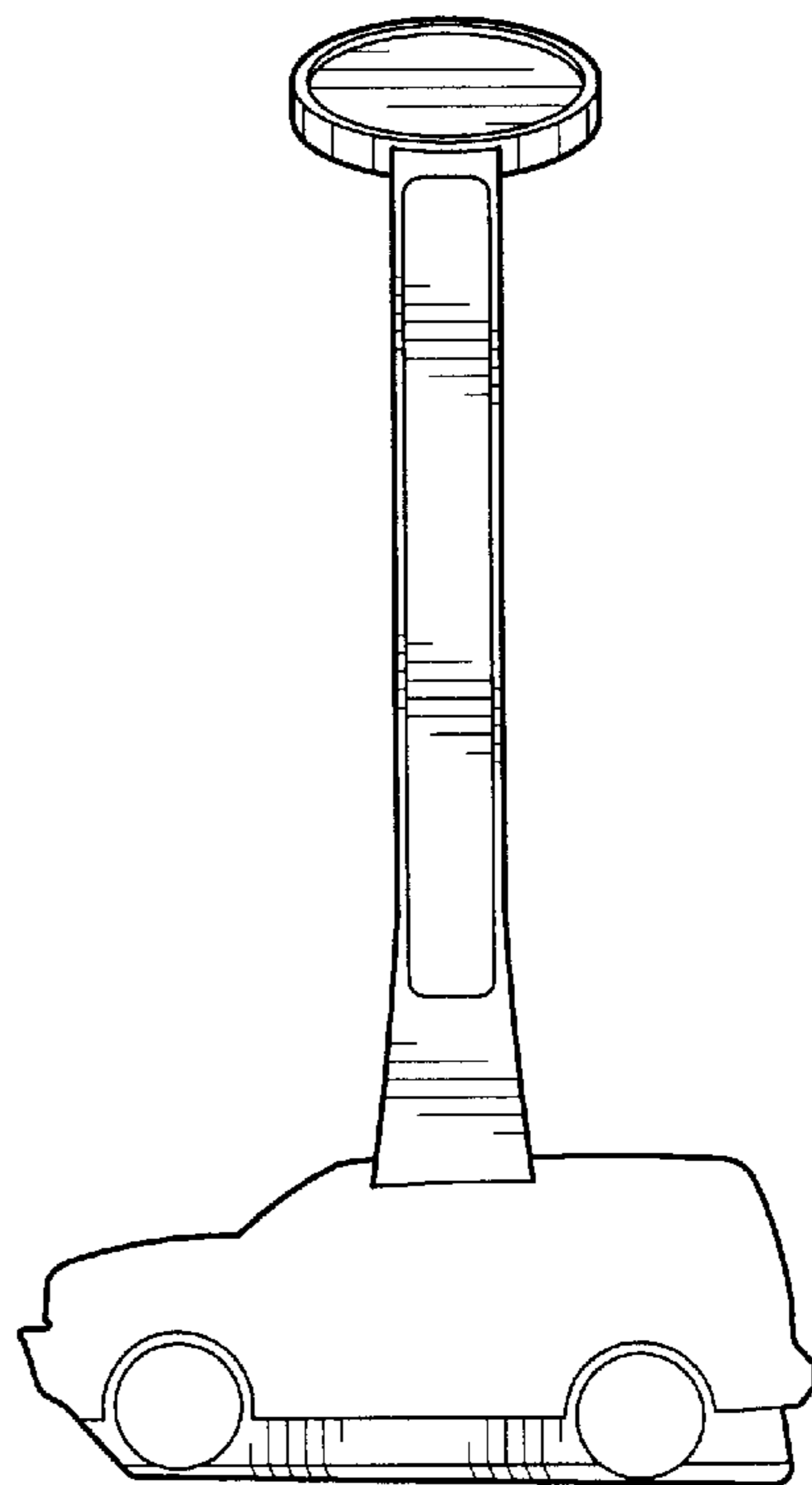

Fig-8