



US00D410969S

# United States Patent [19]

Sexton et al.

[11] Patent Number: **Des. 410,969**

[45] Date of Patent: **\*\* Jun. 15, 1999**

[54] **ADVERTISING FRAME**

D. 385,582 10/1997 McCracken ..... D20/42  
1,325,008 12/1919 Douglas ..... 40/564

[75] Inventors: **Douglas Sexton**, Burlington, Canada;  
**Peter Murphy**; **Andrew Bissett**, both  
of Auckland, New Zealand

*Primary Examiner*—Alan P. Douglas  
*Assistant Examiner*—Jennifer Rivard  
*Attorney, Agent, or Firm*—Paul S. Sharpe; Marks & Clerk

[73] Assignee: **Sellex Outdoor**, Burlington, Canada

[57] **CLAIM**

[\*\*] Term: **14 Years**

The ornamental design for an advertising frame, as shown.

[21] Appl. No.: **29/095,391**

**DESCRIPTION**

[22] Filed: **Oct. 22, 1998**

FIG. 1 is a perspective view of the design showing the front of the article;

[51] **LOC (6) Cl.** ..... **20-03**

FIG. 2 is a perspective view of the design showing the rear of the article;

[52] **U.S. Cl.** ..... **D20/43; D20/10**

[58] **Field of Search** ..... D20/10, 15, 19,  
D20/43; D6/300; 40/700, 725, 605, 618,  
584, 564

FIG. 3 is a front elevation view of the design;

FIG. 4 is a rear elevation view of the design;

FIG. 5 is a top plan view of the design;

FIG. 6 is a bottom plan view of the design;

FIG. 7 is a side view of one side of the design; and,

FIG. 8 is a side view of the other side of the design.

[56] **References Cited**

**U.S. PATENT DOCUMENTS**

D. 109,232 4/1938 Rosenthal ..... D20/10  
D. 375,170 10/1996 Rose et al. .... D20/10 X

**1 Claim, 3 Drawing Sheets**

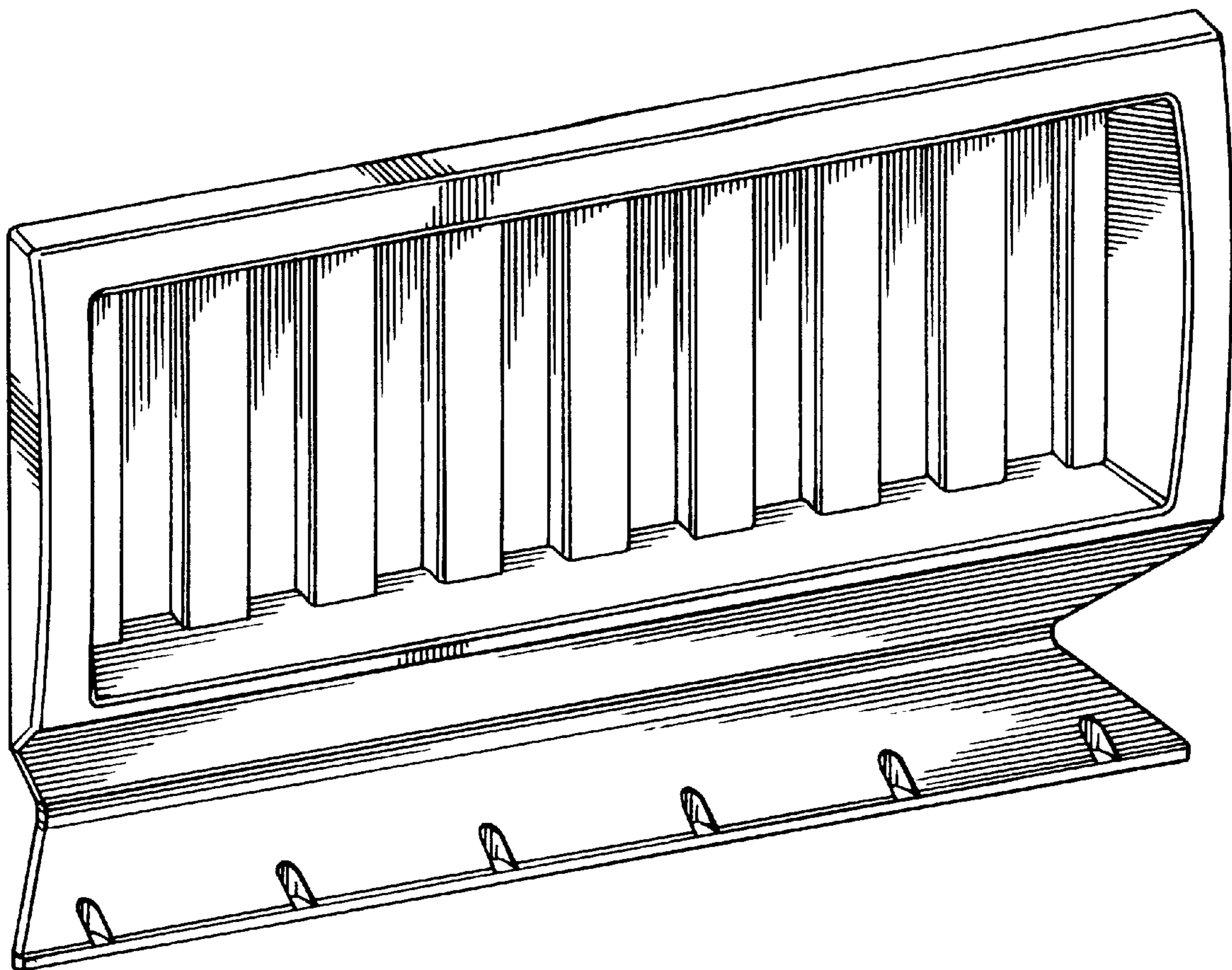

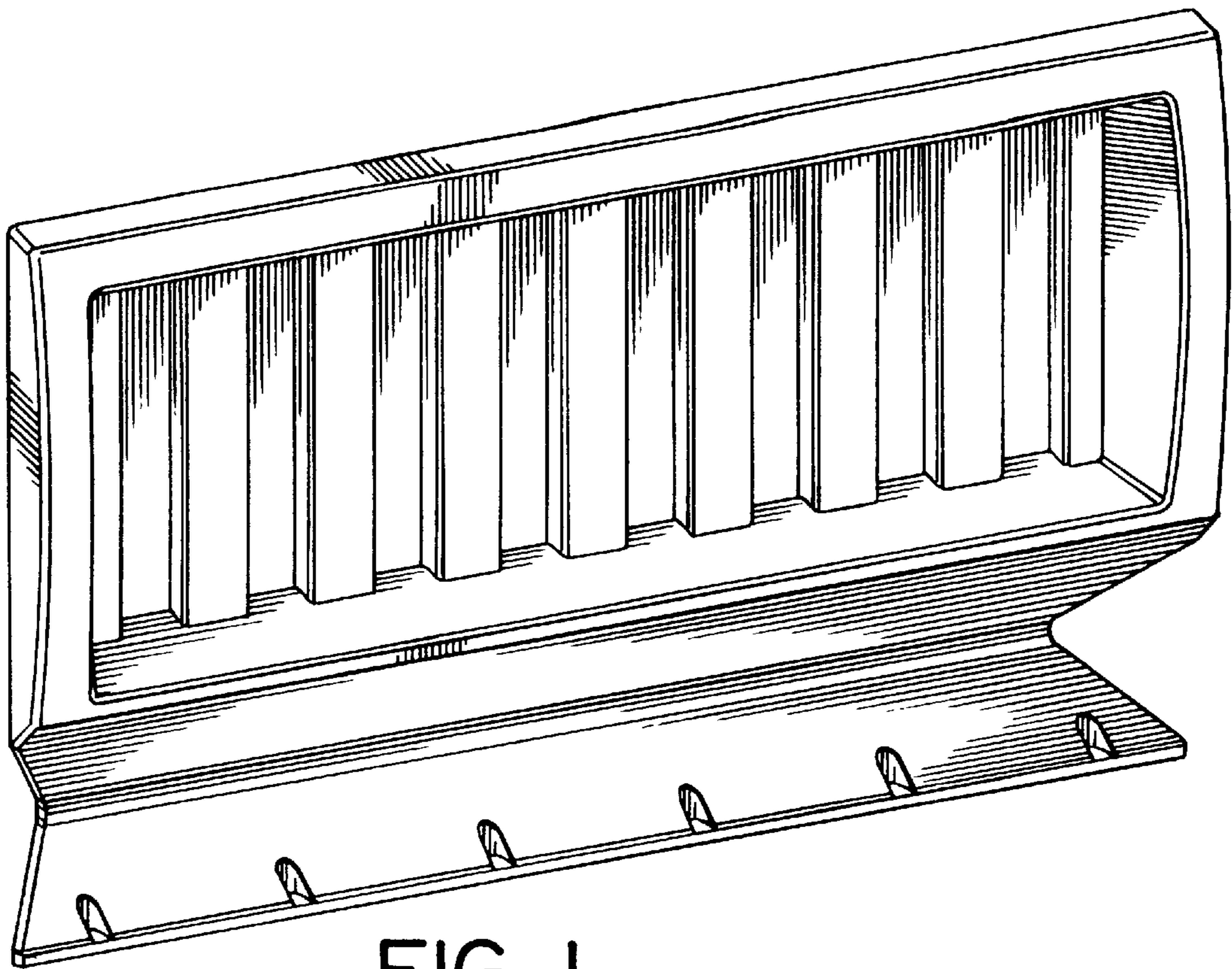

FIG. 1

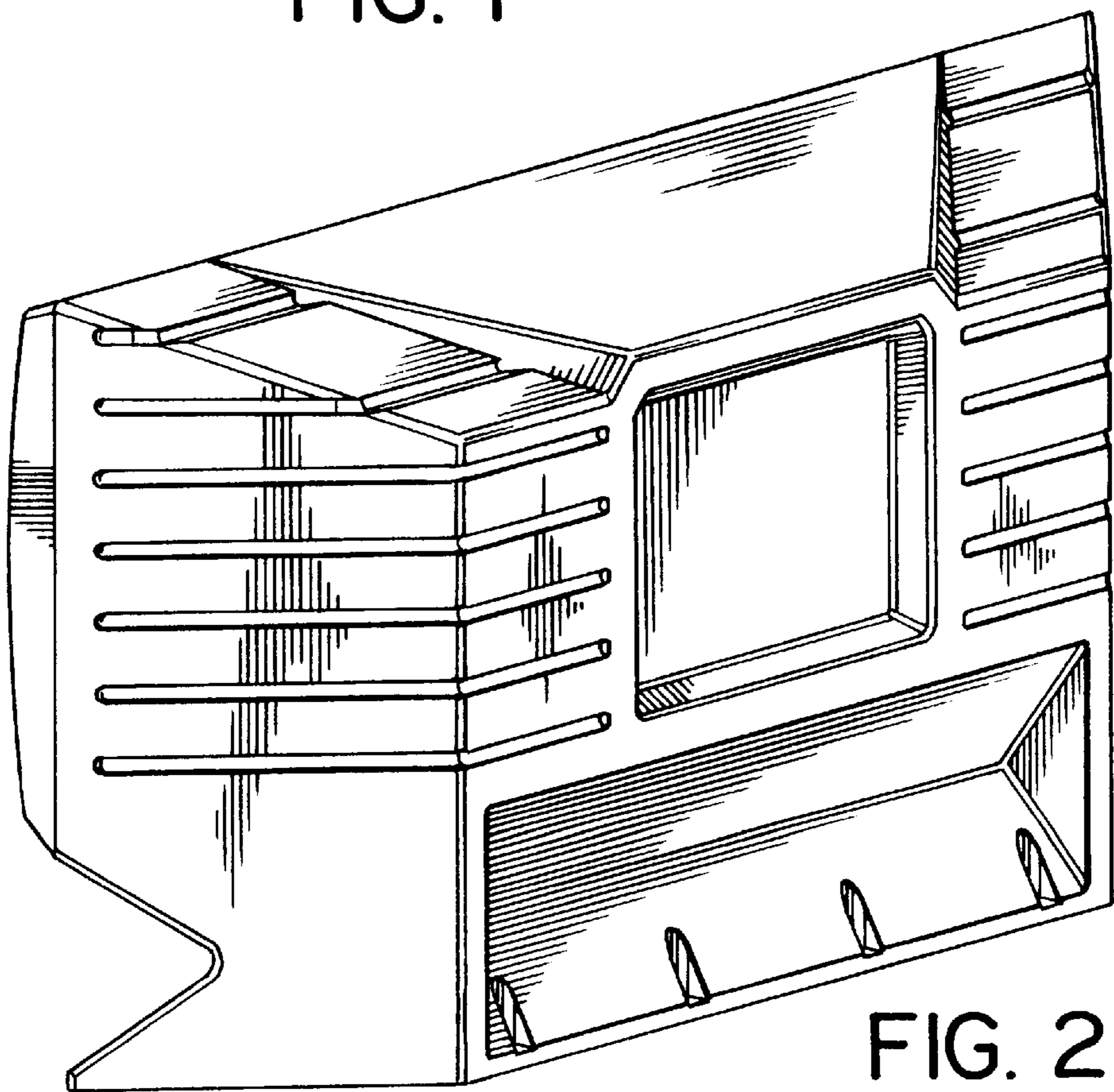

FIG. 2

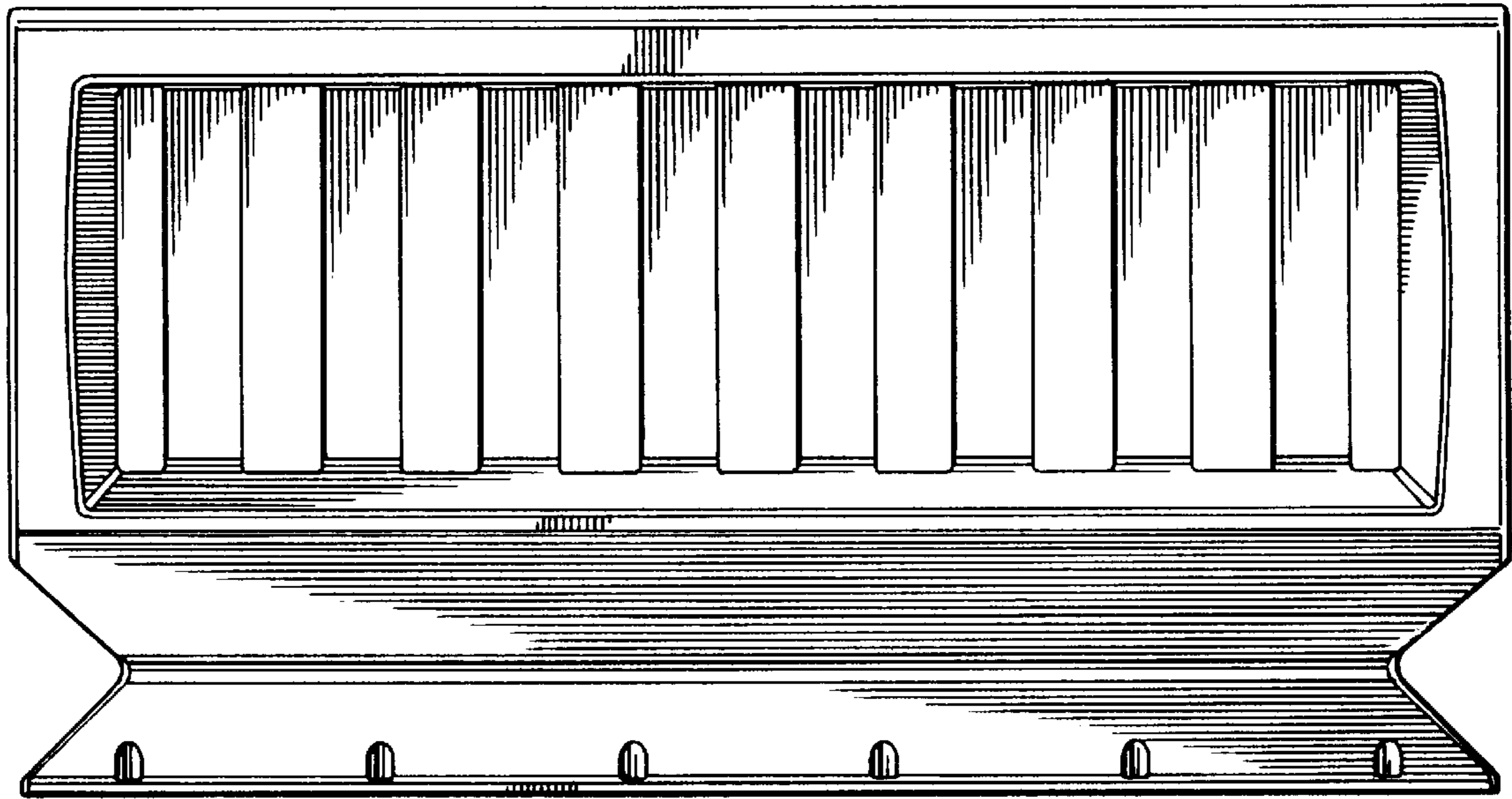

FIG. 3

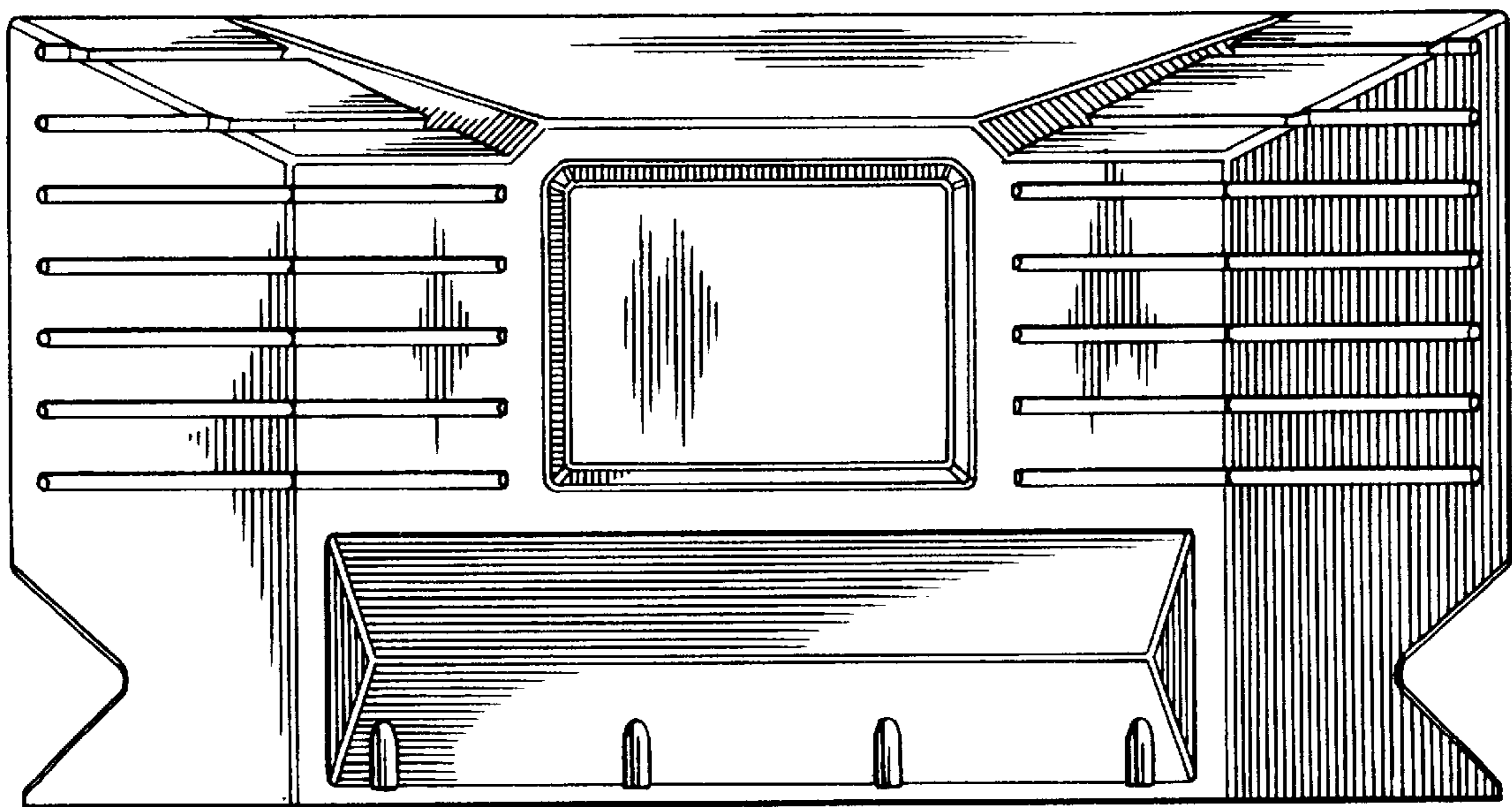

FIG. 4



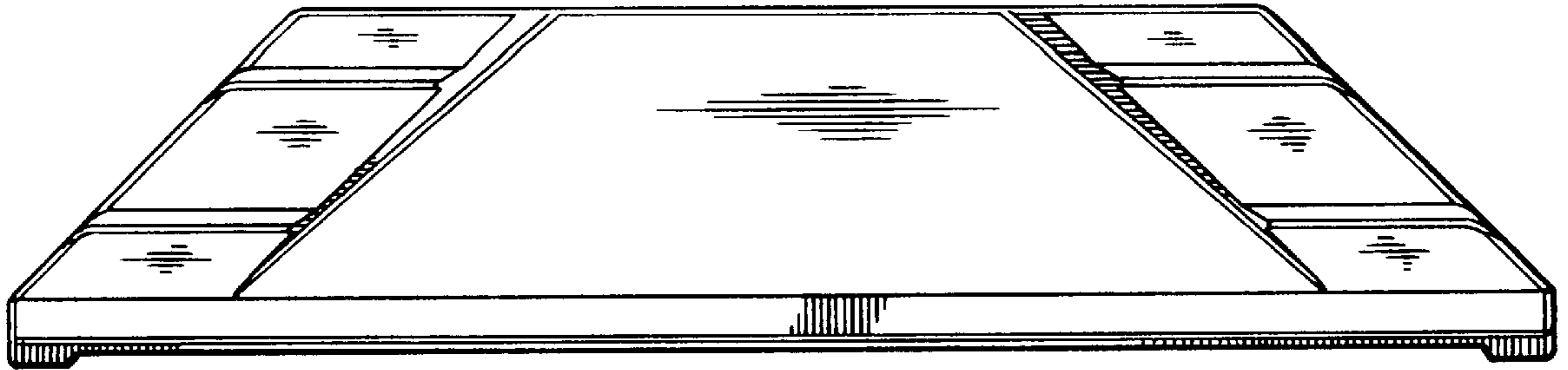

FIG. 5

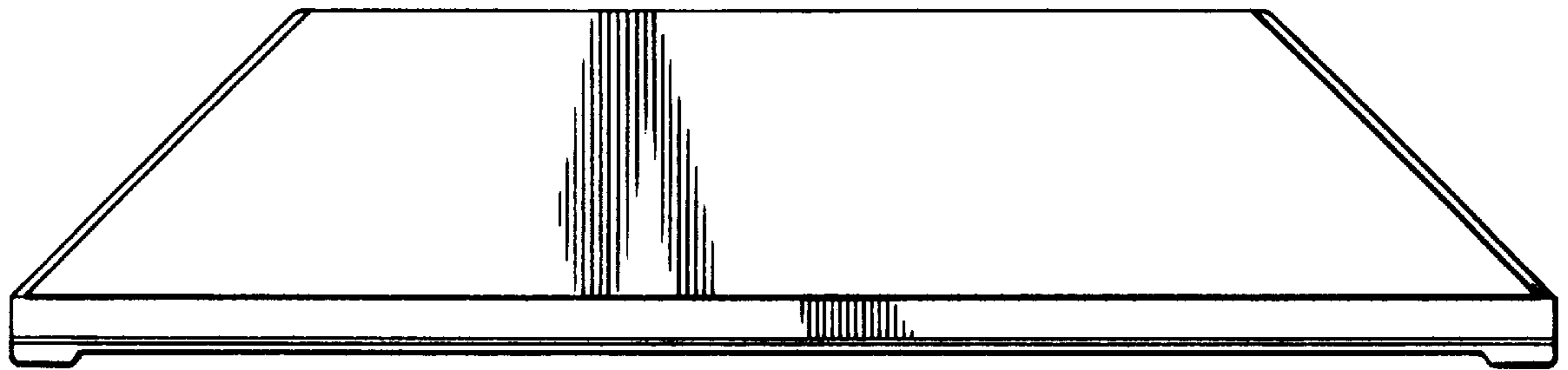

FIG. 6

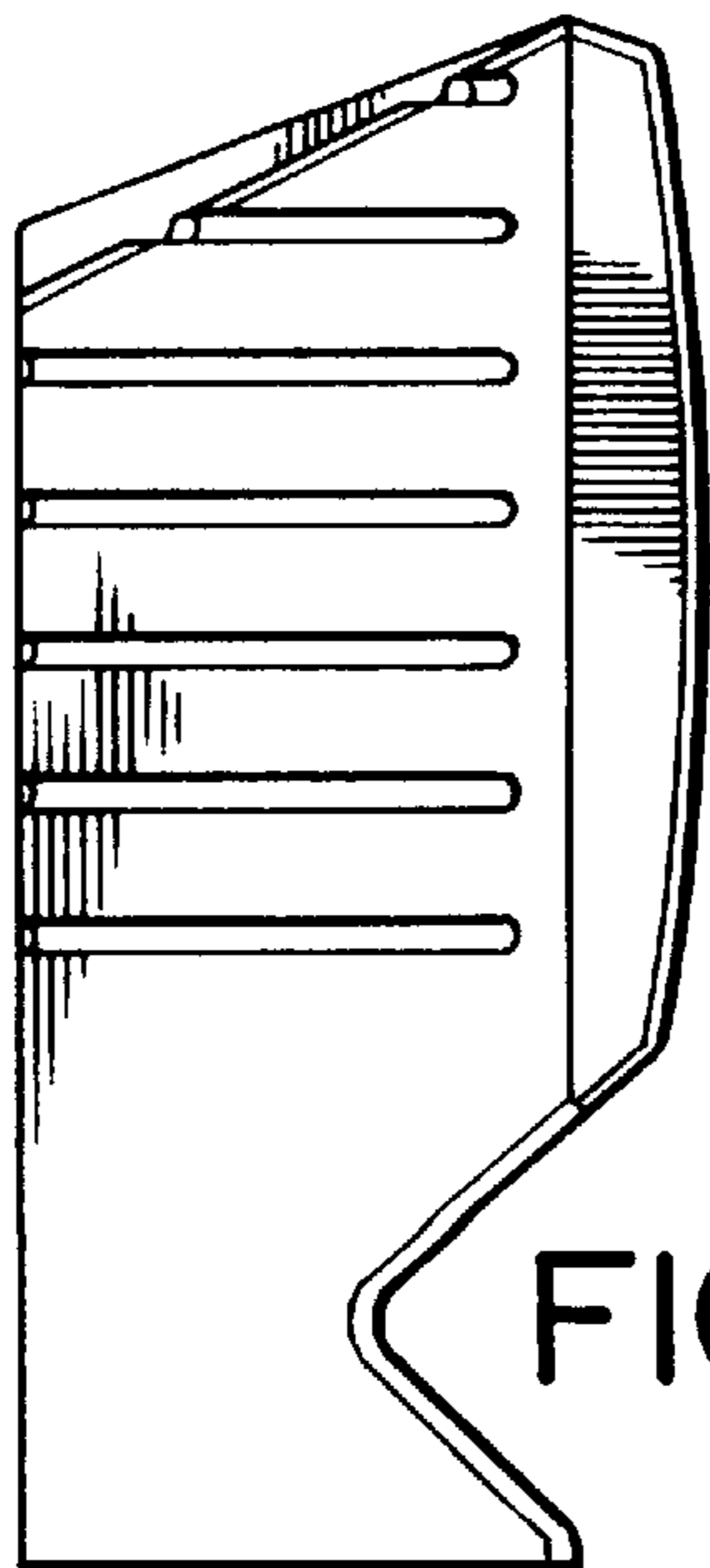

FIG. 7

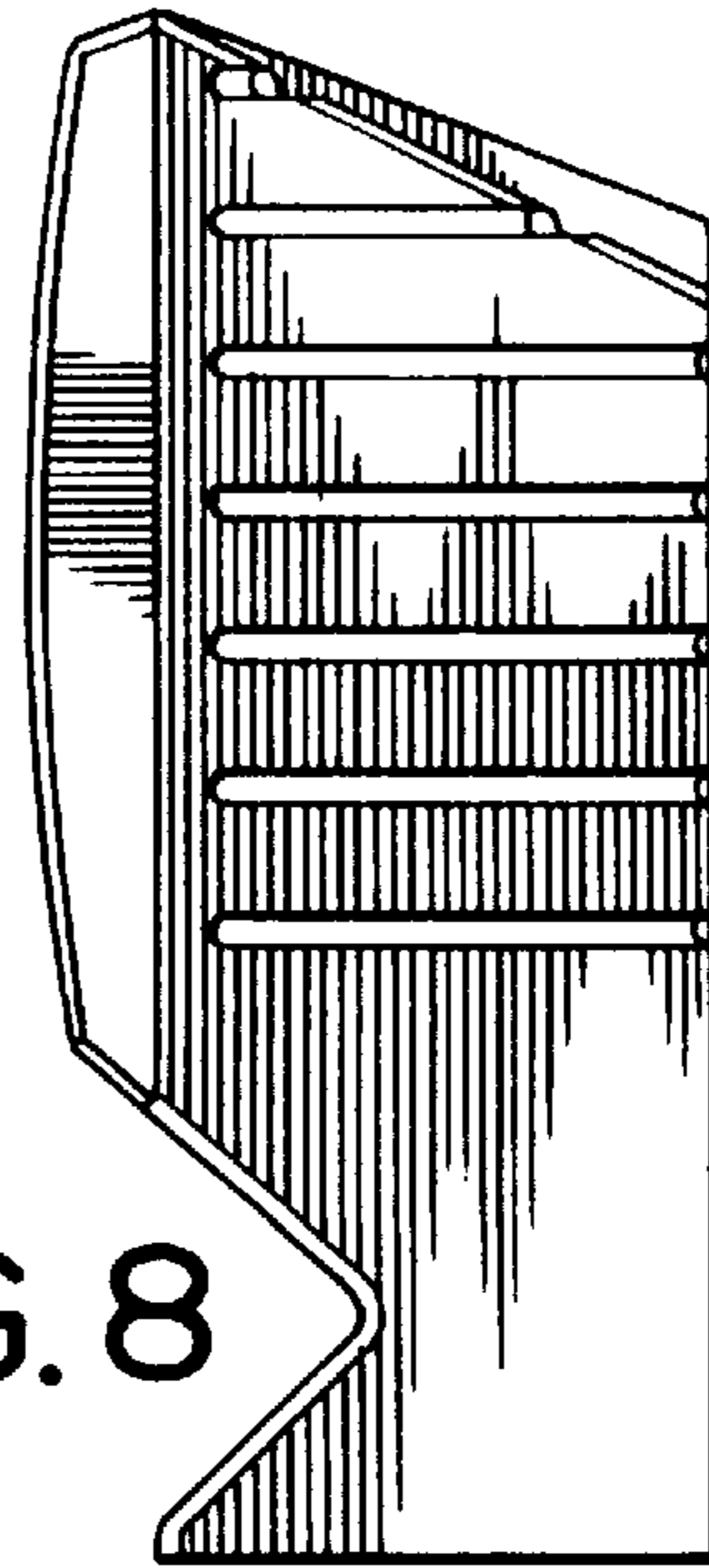

FIG. 8