



US00D410887S

United States Patent [19] Henry

[11] Patent Number: **Des. 410,887**

[45] Date of Patent: **** Jun. 15, 1999**

[54] **WHEEL CHOCK**

5,173,018 12/1992 Kissel et al. 188/32
5,687,516 11/1997 Sheehan et al. 188/32

[76] Inventor: **Stephen K. Henry**, 3815 Northbrook Dr., C-21, Boulder, Colo. 80302

Primary Examiner—Robert M. Spear
Attorney, Agent, or Firm—Dorr, Carson, Sloan & Birney, P.C.

[**] Term: **14 Years**

[21] Appl. No.: **29/091,791**

[57] CLAIM

[22] Filed: **Aug. 5, 1998**

The ornamental design for a wheel chock, as shown and described.

Related U.S. Application Data

DESCRIPTION

[62] Division of application No. 29/066,670, Feb. 13, 1997.

[51] **LOC (6) Cl.** **12-06**

[52] **U.S. Cl.** **D12/217**

[58] **Field of Search** D12/114, 120,
D12/217; 188/4 R, 32; 224/524; 267/139,
140; 280/293

FIG. 1 is a front perspective view of a wheel chock showing my new design.

FIG. 2 is a top plan view thereof.

FIG. 3 is front elevational view thereof, taken in the direction of arrow 3—3 in FIG. 2, with the rear elevational view being a mirror image of FIG. 3.

FIG. 4 is a left side elevational view thereof, taken in the direction of arrow 4—4 in FIG. 3.

FIG. 5 is a right side elevational view thereof, taken in the direction of arrow 5—5 in FIG. 3.

FIG. 6 is a bottom plan view thereof, taken in the direction of arrow 6—6 in FIG. 3; and,

FIG. 7 is a bottom plan view of an alternative embodiment of a wheel chock showing my new design.

[56] References Cited

U.S. PATENT DOCUMENTS

2,011,469	8/1935	Brueggeman	188/32
2,992,704	7/1961	Showaker et al.	188/32
3,289,794	12/1966	Miles	188/32
3,317,006	5/1967	Patterson	188/32
3,720,406	3/1973	Artz	188/32
4,641,994	2/1987	Hankison	188/32

1 Claim, 3 Drawing Sheets

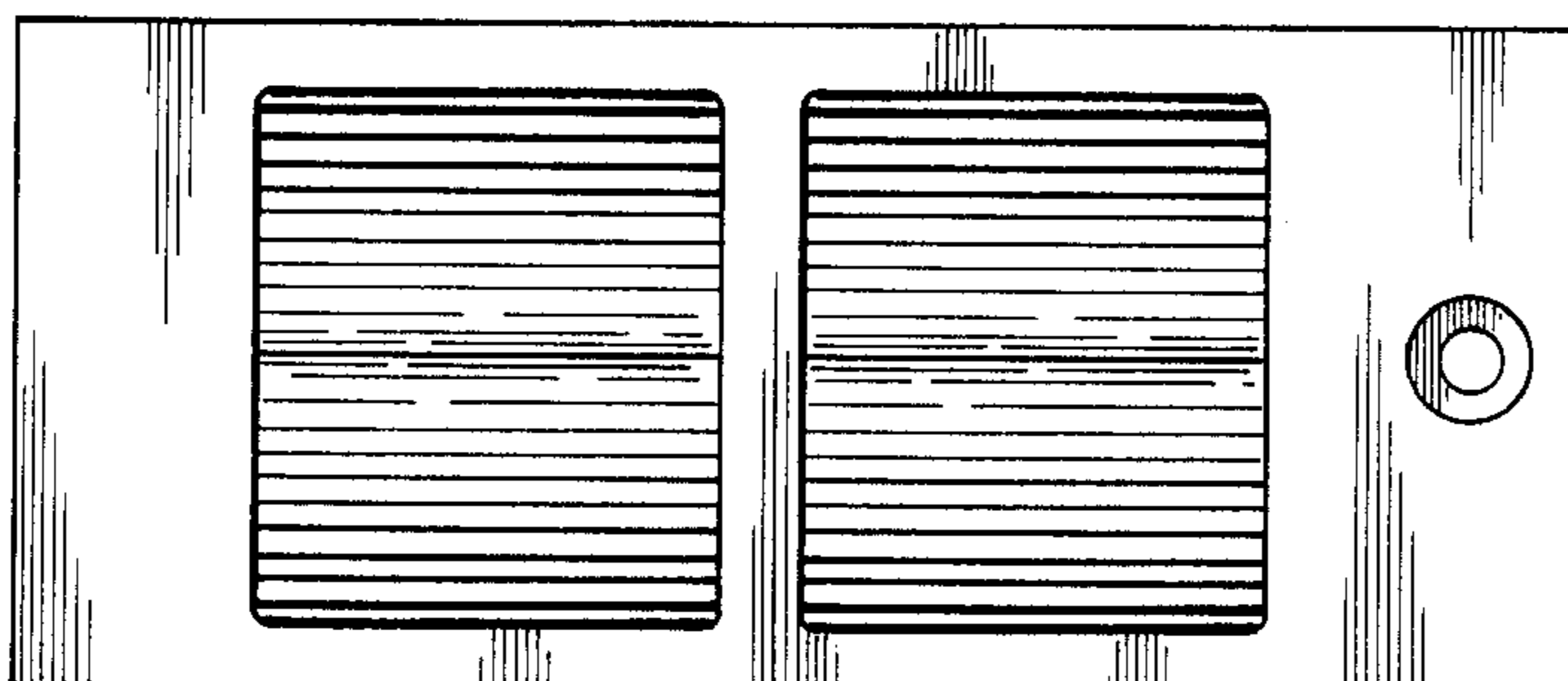
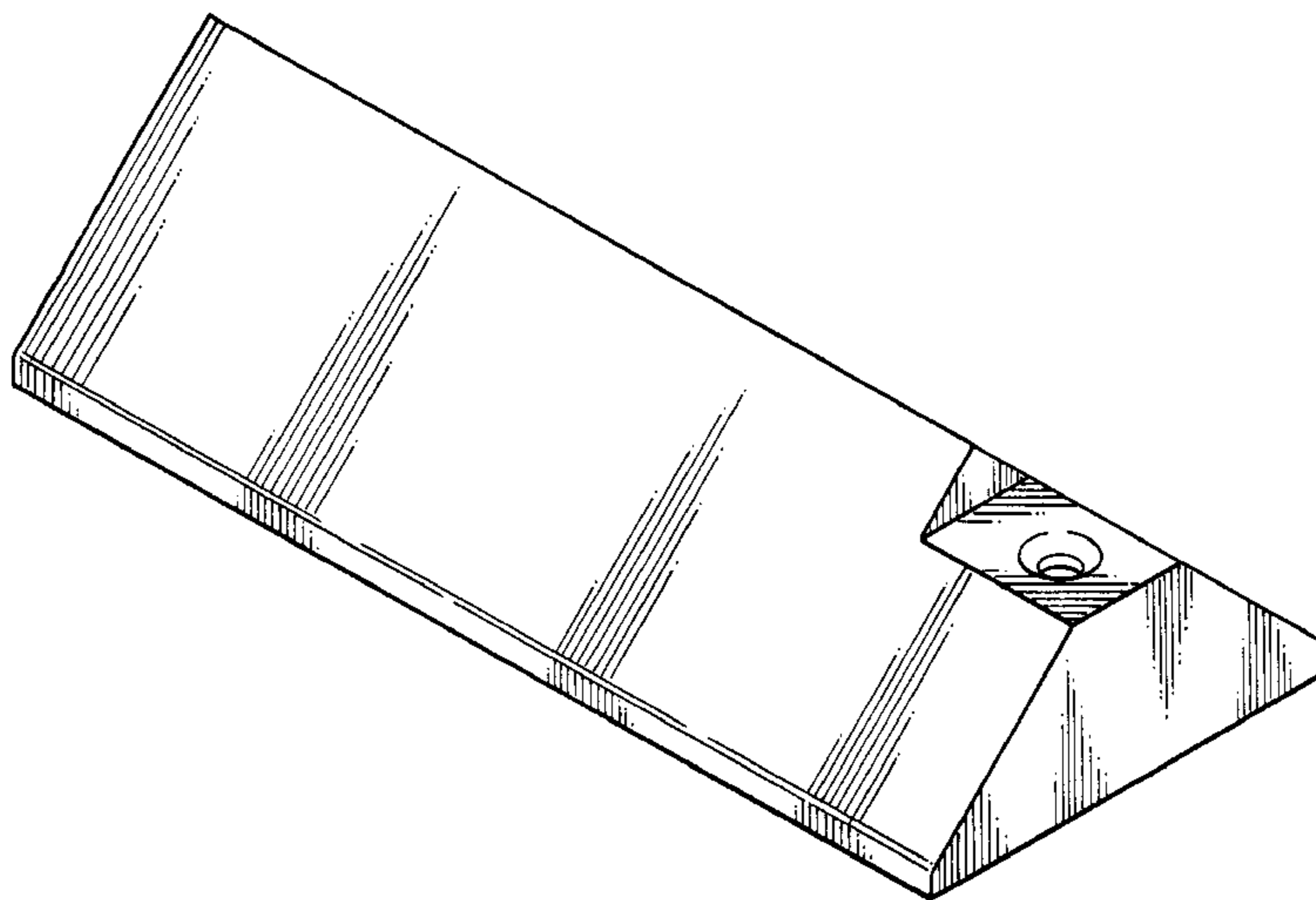

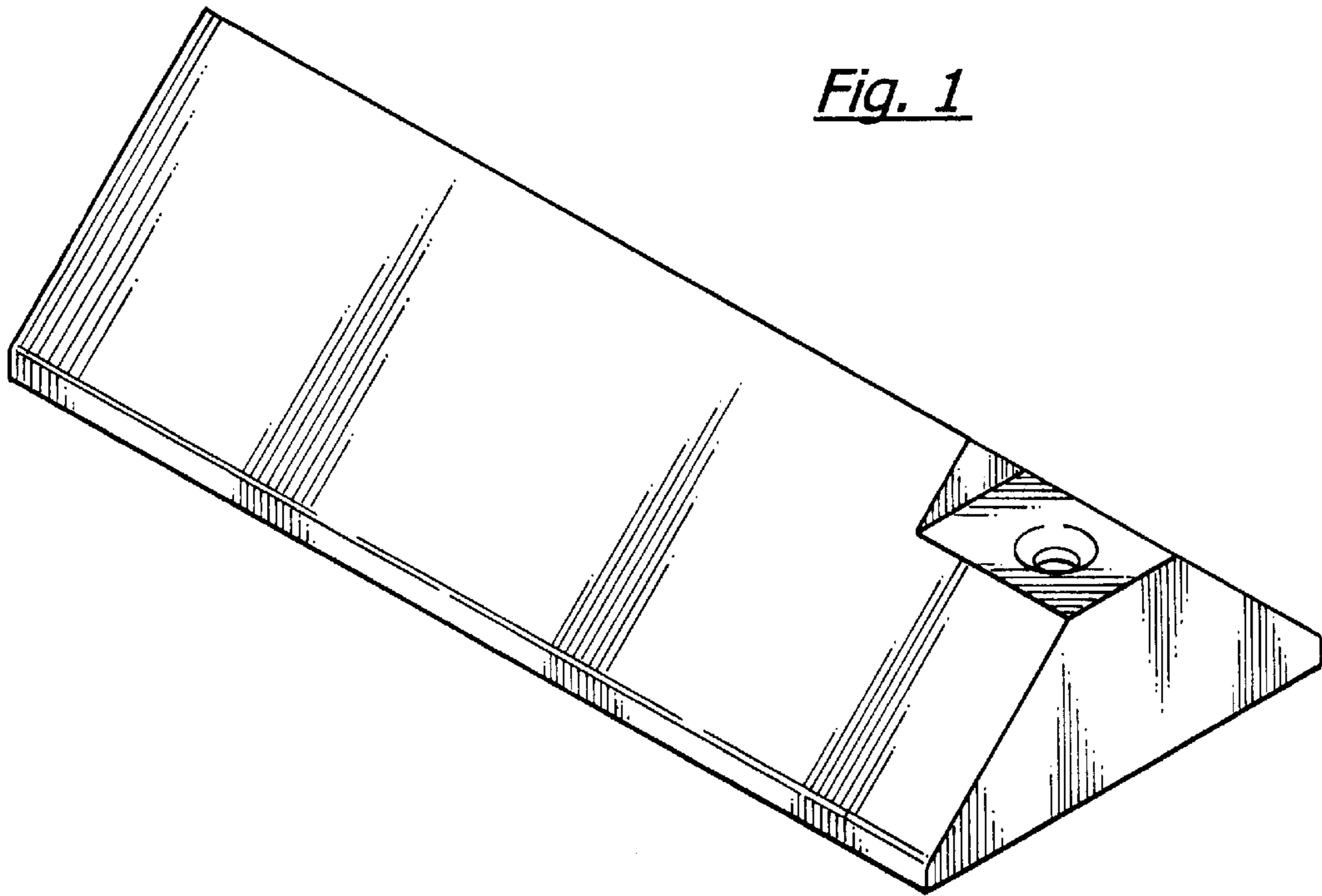

Fig. 2

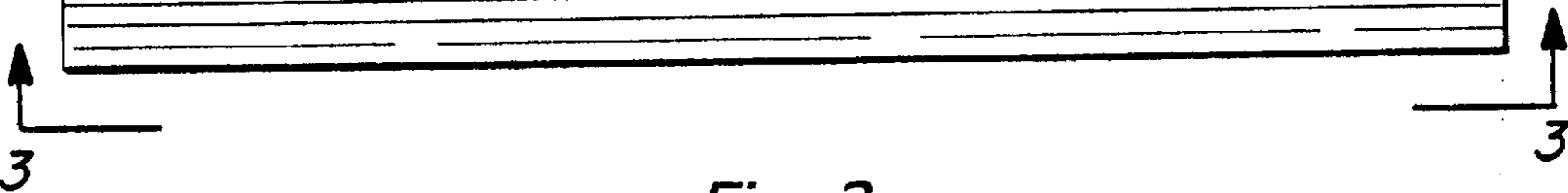
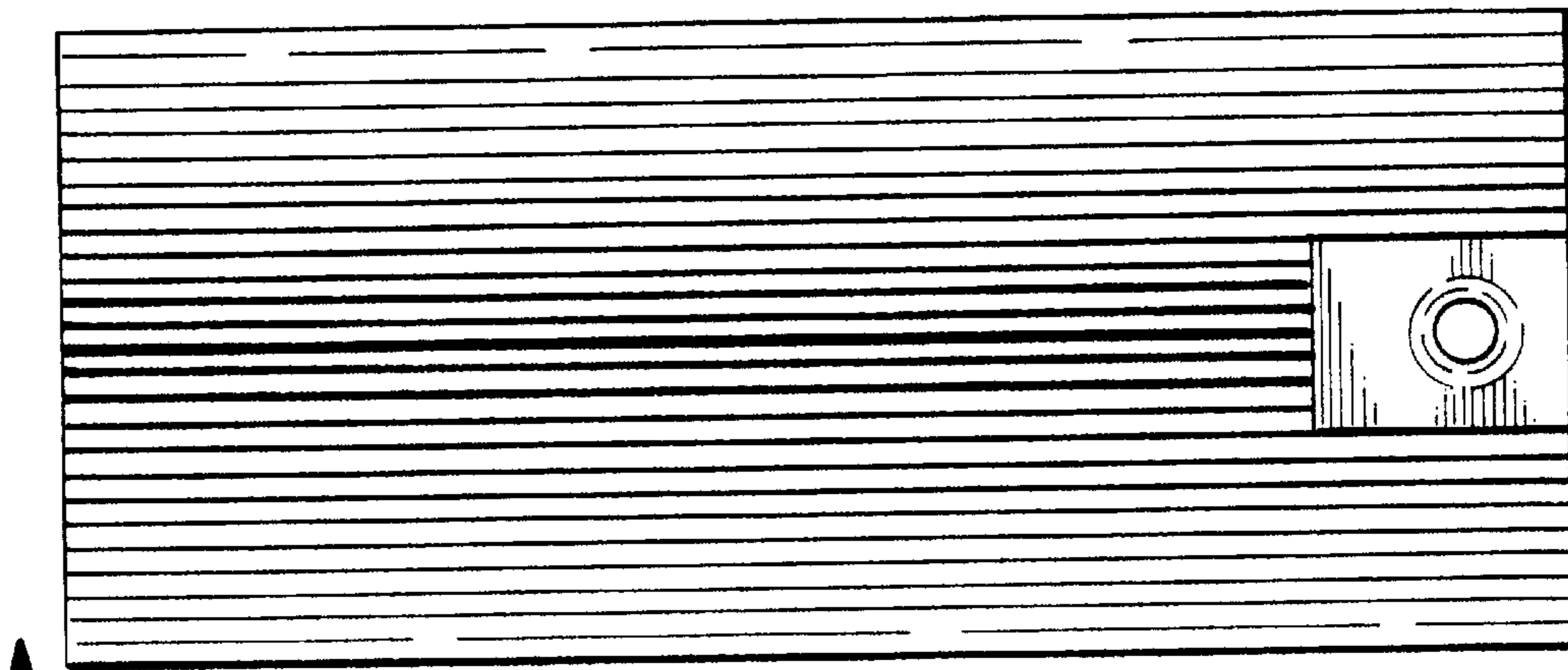

Fig. 3

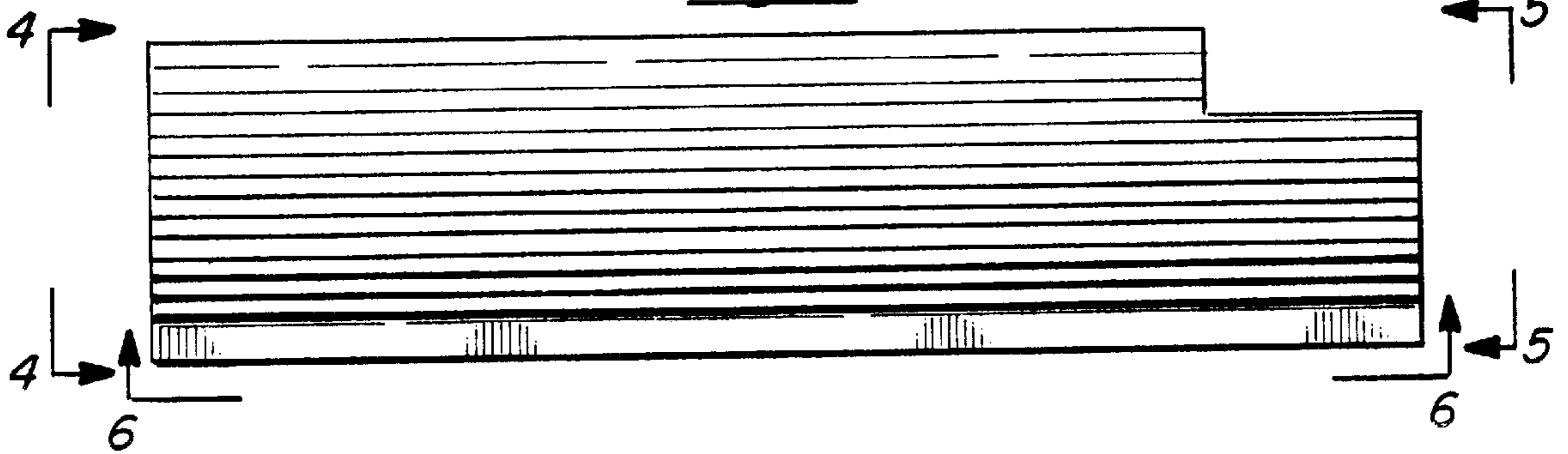

Fig. 4

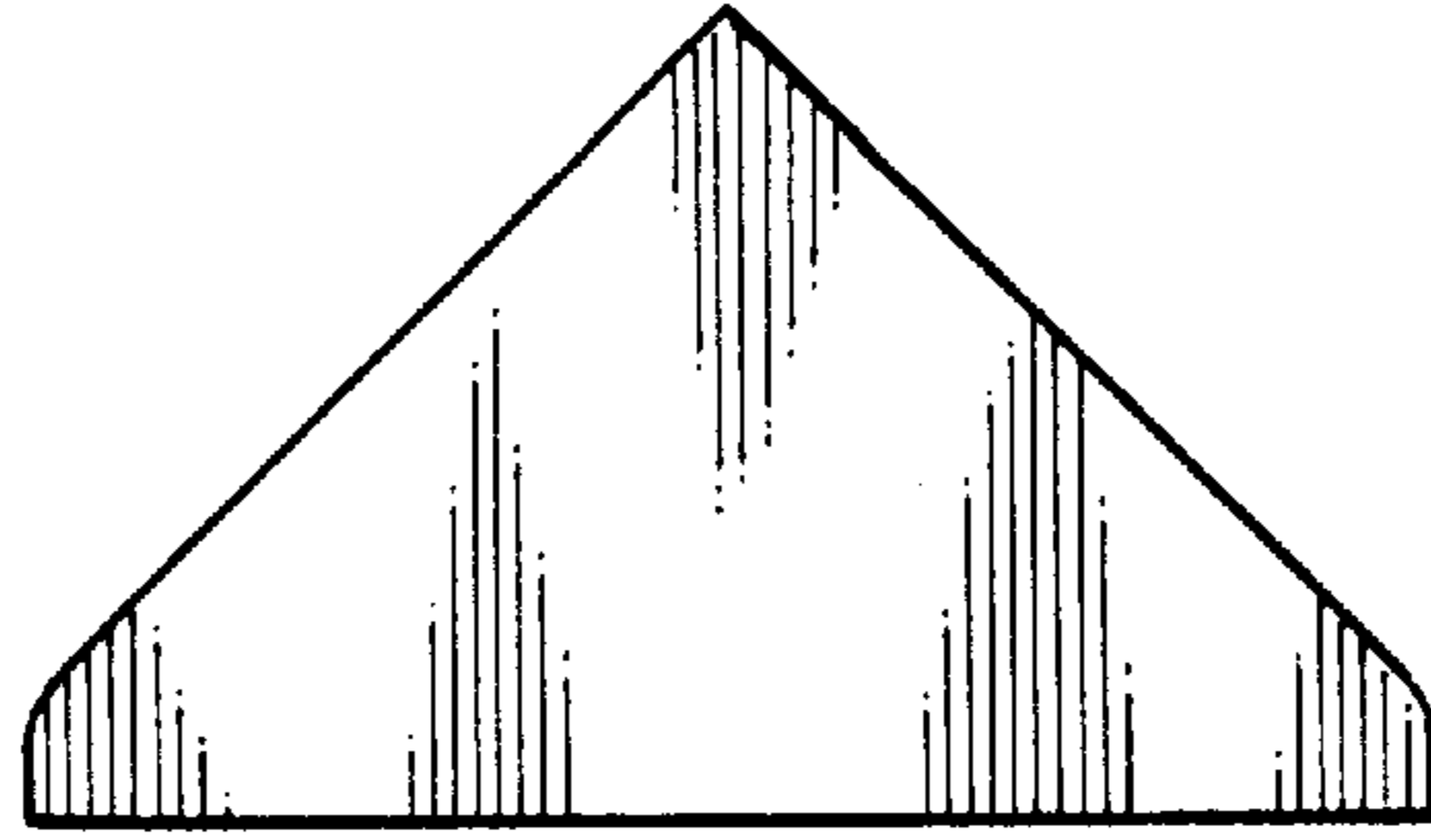

Fig. 5

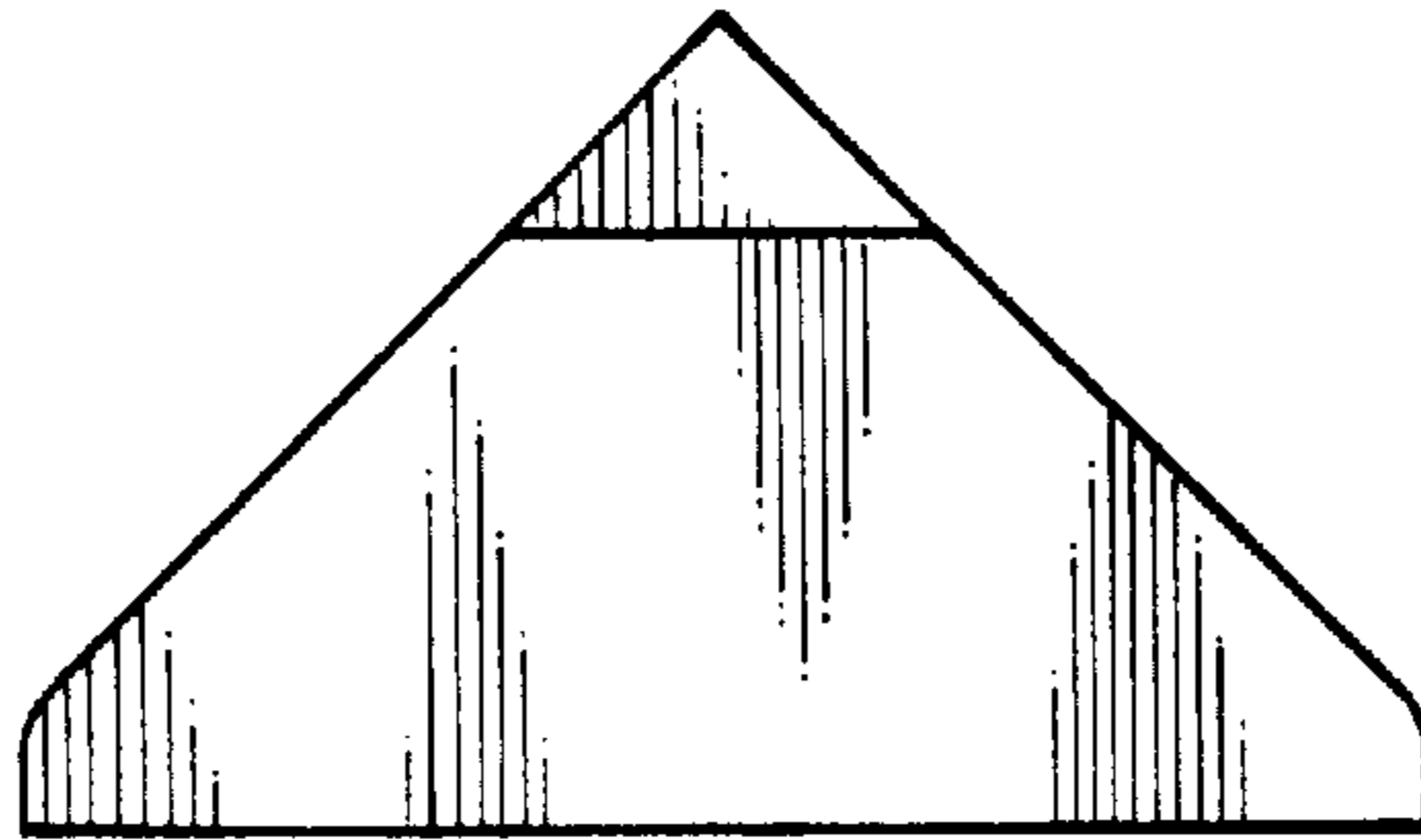

Fig. 6

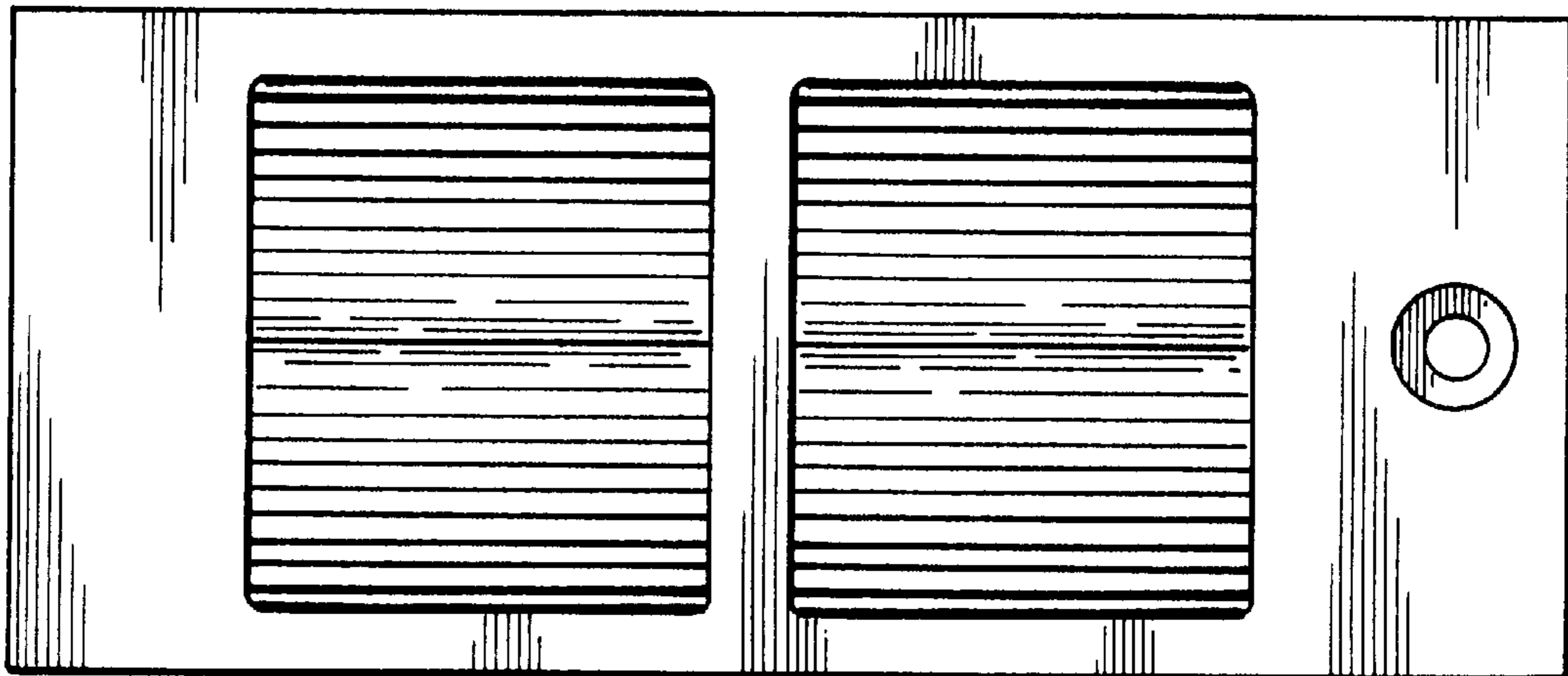

Fig. 7

