



US00D410870S

United States Patent [19]

[11] **Patent Number: Des. 410,870**

Golden et al.

[45] **Date of Patent: ** Jun. 15, 1999**

[54] **MOTORCYCLE CRANK CASE**

Drag Specialties Catalog, p. 168 the Delkron Engine Cases for SS-91 Big Twin Motorcycles ©1995.

[75] Inventors: **Earl F. Golden**, Milwaukee; **Robert L. Leppanen**, Wauwatosa, both of Wis.

Primary Examiner—Melody N. Brown
Attorney, Agent, or Firm—Michael, Best & Friedrich LLP

[73] Assignee: **Harley-Davidson Motor Company**

[**] Term: **14 Years**

[57] CLAIM

[21] Appl. No.: **29/077,238**

The ornamental design for a motorcycle crank case, as shown.

[22] Filed: **Sep. 30, 1997**

[51] **LOC (6) Cl.** **12-11**

DESCRIPTION

[52] **U.S. Cl.** **D12/114**

[58] **Field of Search** D12/126, 114,
D12/110; 180/219; 288/288.4

FIG. 1 is a top perspective view of a motorcycle crank case showing our new design;

FIG. 2 is a top plan view thereof;

FIG. 3 is a front elevational view thereof;

FIG. 4 is a right side elevational view thereof; and,

FIG. 5 is a left side elevational view thereof.

[56] References Cited

U.S. PATENT DOCUMENTS

D. 333,806	3/1993	Davidson	D12/110
D. 336,451	6/1993	Huebner	D12/126
D. 395,621	6/1998	Nishino	D12/110
D. 396,204	7/1998	Kishi et al.	D12/110

The broken lines shown in all views of the drawing are for illustrative purposes only and form no part of the claimed design.

OTHER PUBLICATIONS

Harley-Davidson Motor Company 1993 and 1994 1340 Models Parts Catalog, p. 14.
1994 V-Twin Manufacturing, p. 13.

1 Claim, 3 Drawing Sheets

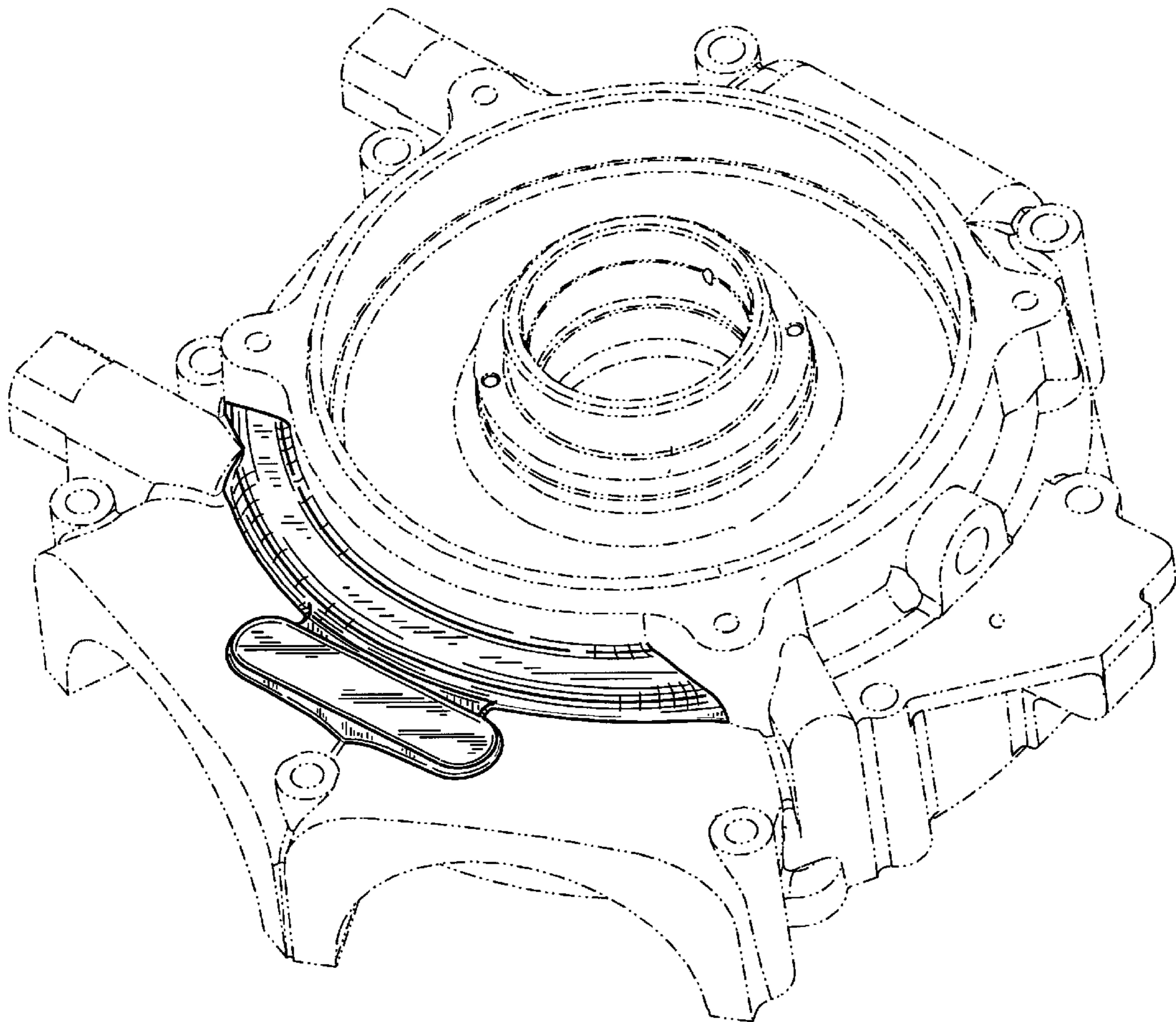

FIG. 1

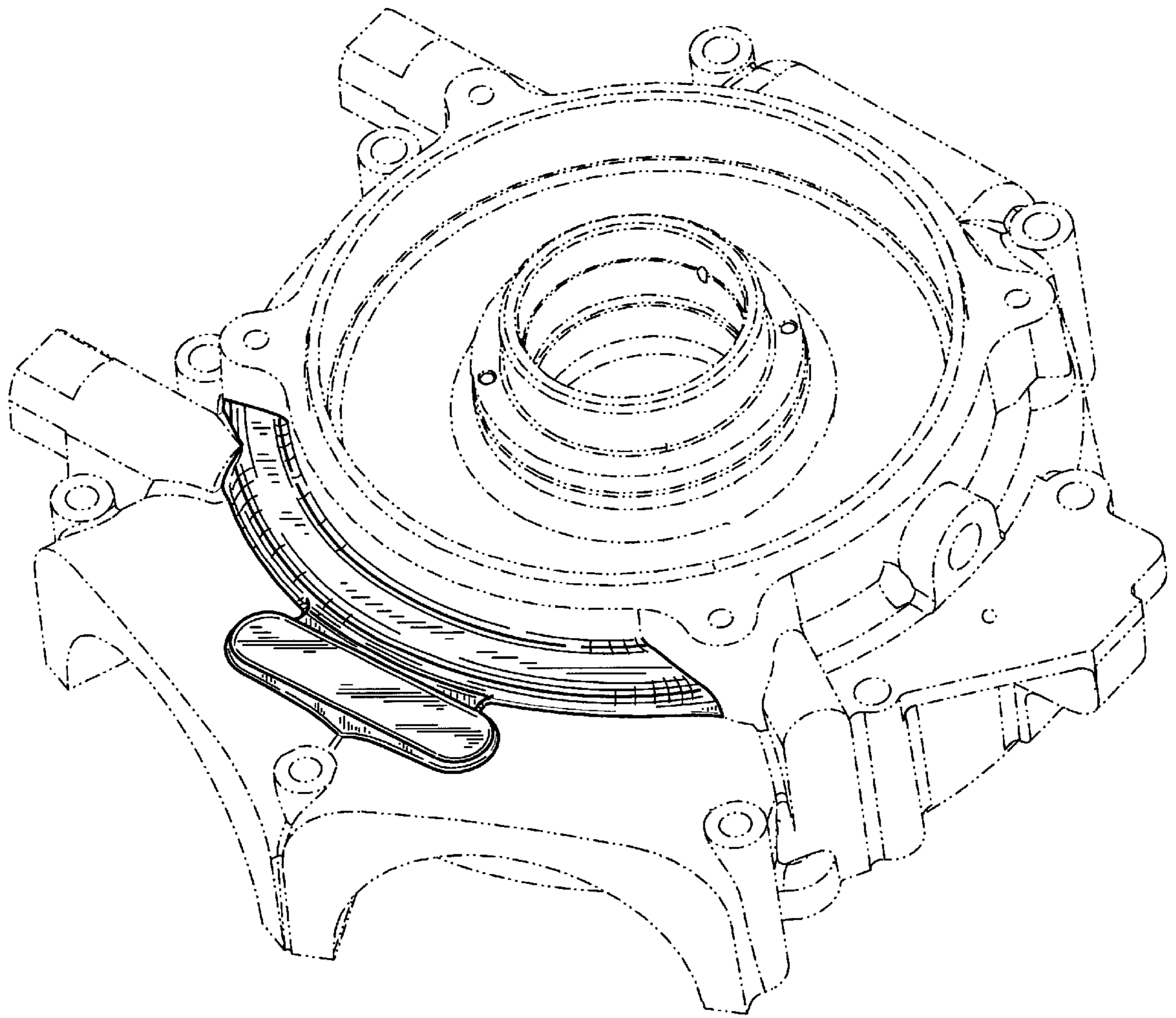

FIG. 2

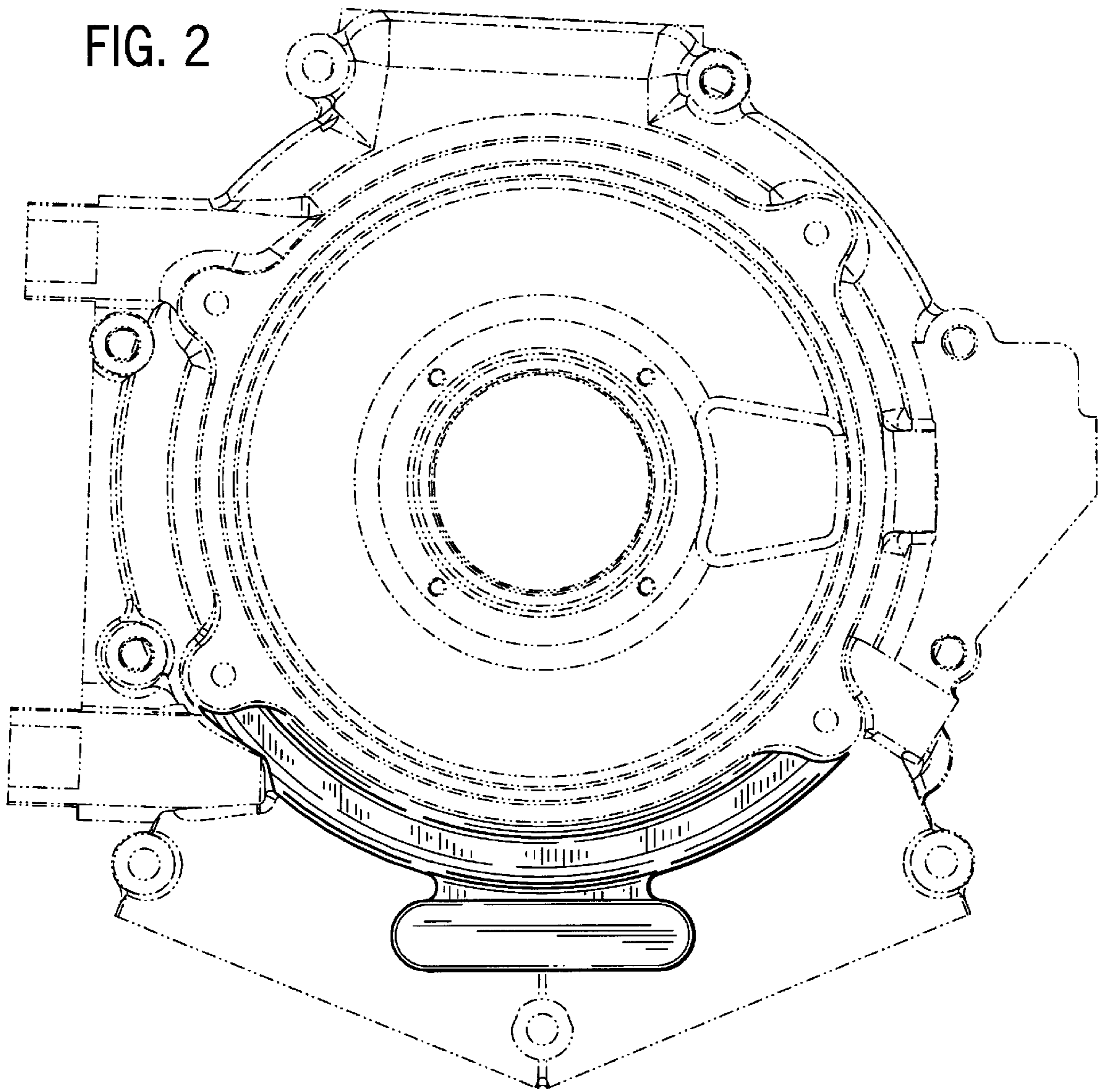

FIG. 3

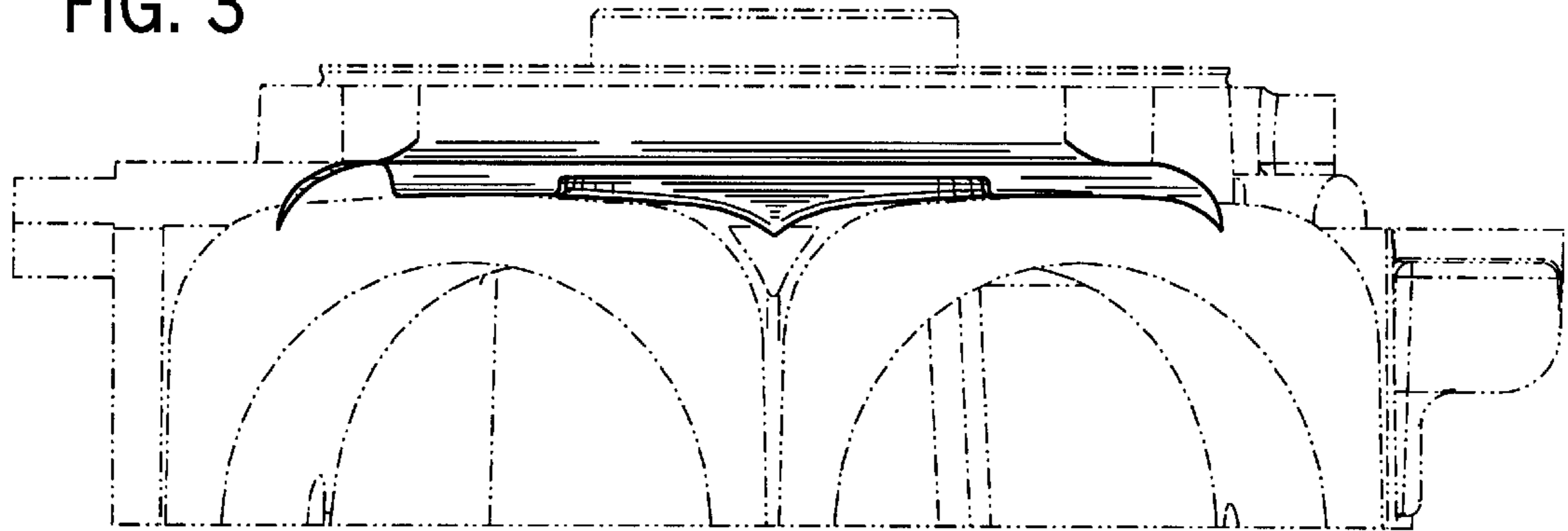

FIG. 4

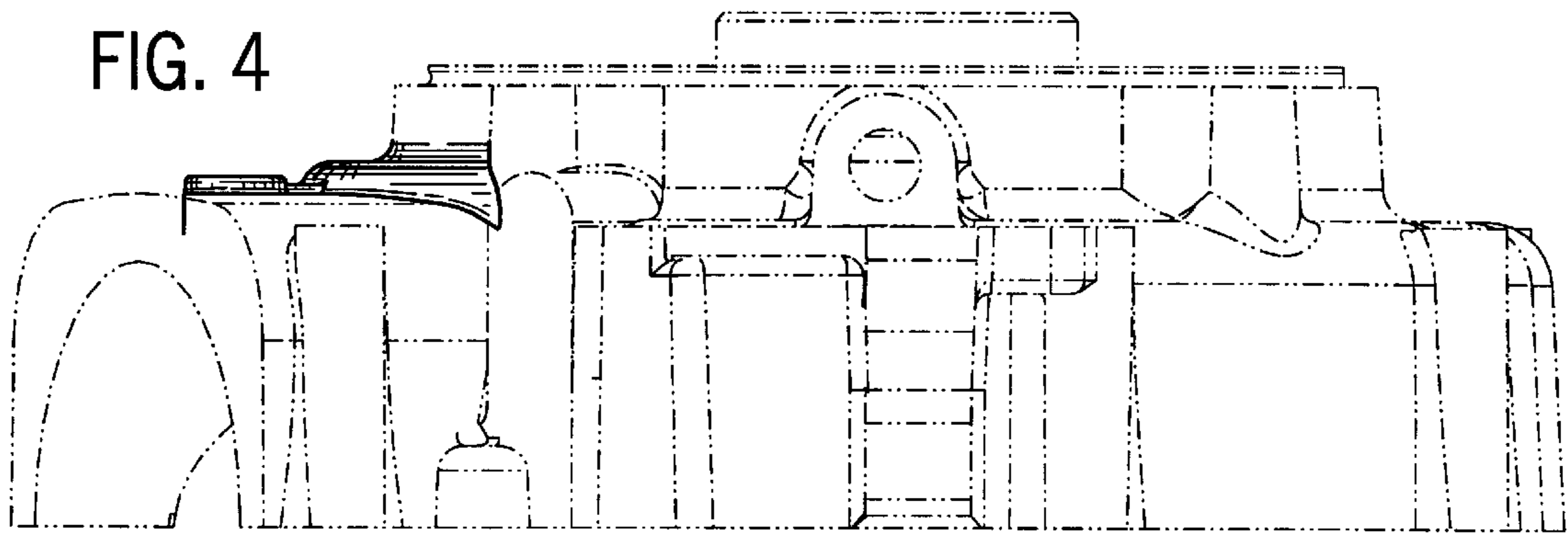

FIG. 5

