



US00D410602S

# United States Patent [19] Matsuda

[11] **Patent Number: Des. 410,602**  
[45] **Date of Patent: \*\* Jun. 8, 1999**

## [54] **AUTOMOBILE TIRE**

[75] **Inventor: Shoichiro Matsuda, Kanawaga-ken, Japan**

[73] **Assignee: The Yokohama Rubber Co., Ltd., Tokyo, Japan**

[\*\*] **Term: 14 Years**

[21] **Appl. No.: 29/090,648**

[22] **Filed: Jul. 13, 1998**

[51] **LOC (6) Cl. .... 12-15**

[52] **U.S. Cl. .... D12/147**

[58] **Field of Search .... D12/136, 138, D12/140-152; 152/209 RR, 209 NS, 209 AS, 209 AG, 209 BY, 209 LG, 209 RB, 209 DP**

## [56] **References Cited**

### U.S. PATENT DOCUMENTS

D. 335,841	5/1993	Caretta et al. ....	D12/146
D. 350,926	9/1994	Hutz .....	D12/147
D. 383,422	9/1997	Kunos et al. ....	D12/147
D. 384,614	10/1997	Hanlon et al. ....	D12/147
D. 398,890	9/1998	Harpes et al. ....	D12/147

### FOREIGN PATENT DOCUMENTS

M 94 04 599 10/1994 Germany .

## OTHER PUBLICATIONS

Goodyear Eagle RS-A Tire, 1996 Tread Design Guide, p. 34, Feb. 1996.

Road King Grenadier LTE RWL Tire, 1996 Tread Design Guide, p. 63, Feb. 1996.

*Primary Examiner*—Robert M. Spear  
*Attorney, Agent, or Firm*—Nikaido, Marmelstein, Murray & Oram LLP

## [57] **CLAIM**

The ornamental design for an automobile tire, as shown and described.

## DESCRIPTION

FIG. 1 is a front view of the automobile tire, showing the new design, each of the rear view, the top plan view and the bottom plan view appearing the same as the front view, it being understood that the tread pattern repeats uniformly throughout the circumference of the tire;

FIG. 2 is a right side view of the automobile tire, the left side view appearing the same as the right side view;

FIG. 3 is an enlarged fragmentary front view, showing in enlargement the portion of 3—3 in FIG. 1; and,

FIG. 4 is an enlarged sectional view, taken on line 4—4 and in the direction of arrows in FIG. 3.

**1 Claim, 3 Drawing Sheets**

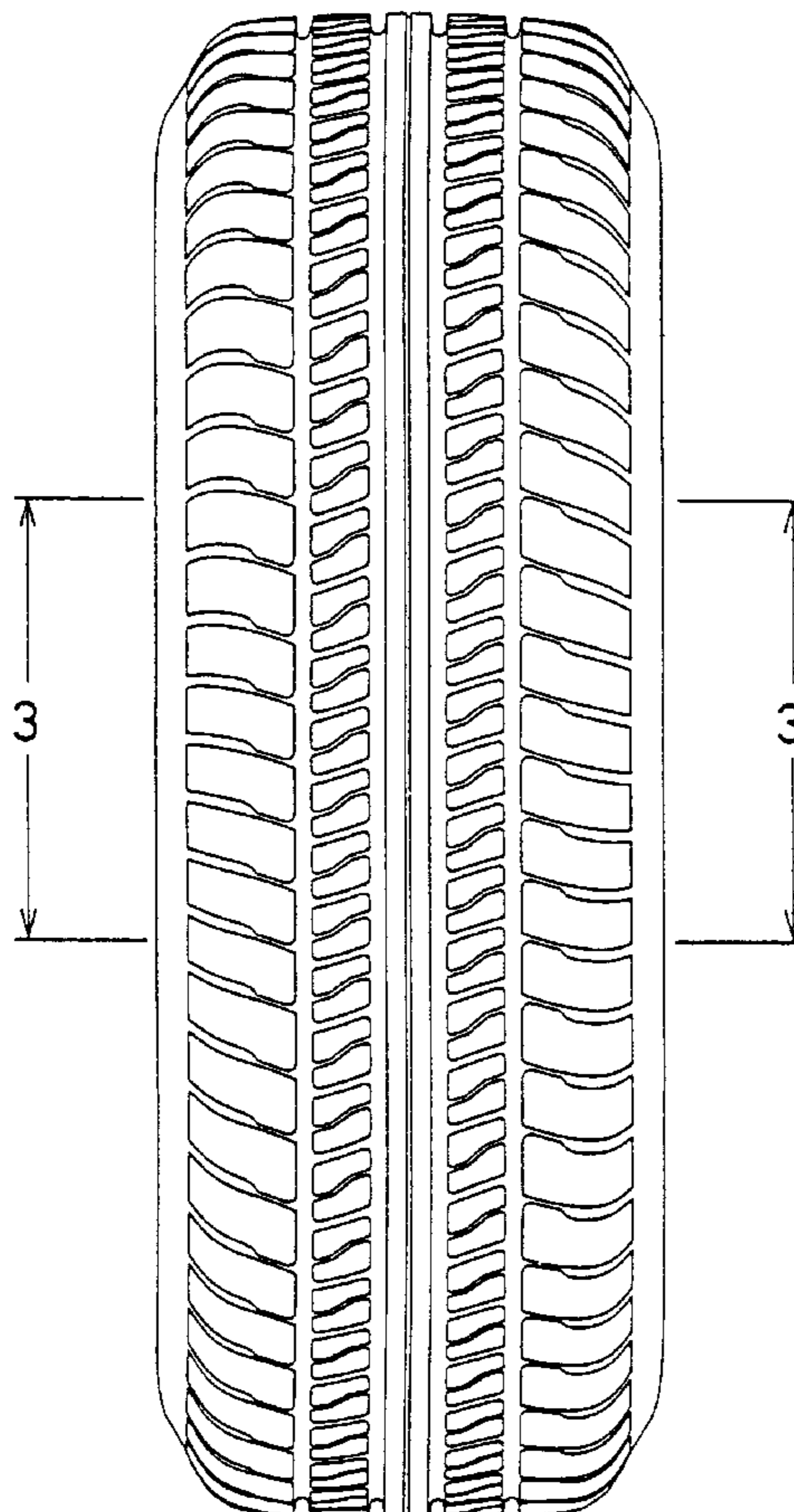

FIG. 1

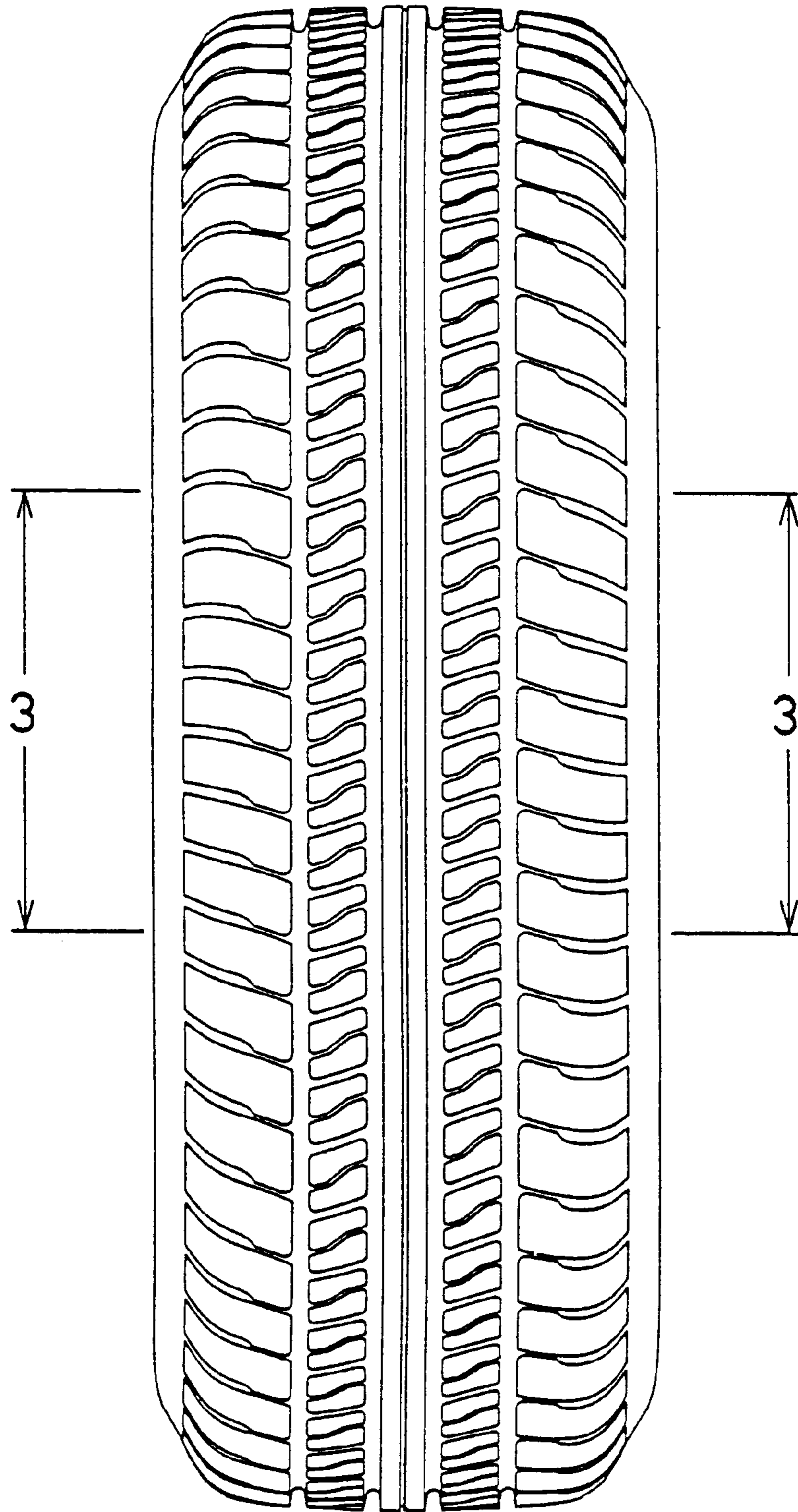

FIG. 2

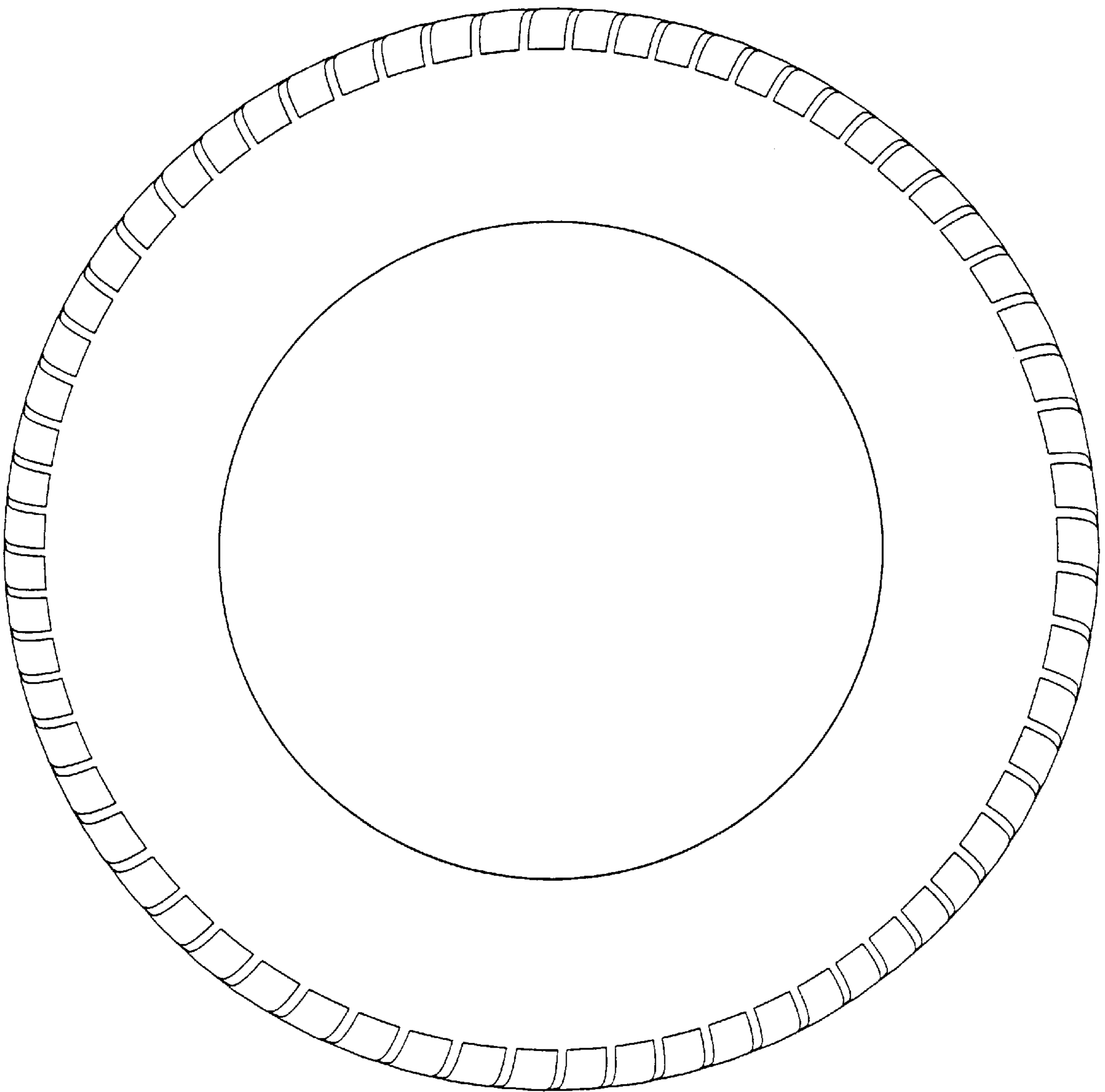

FIG. 3

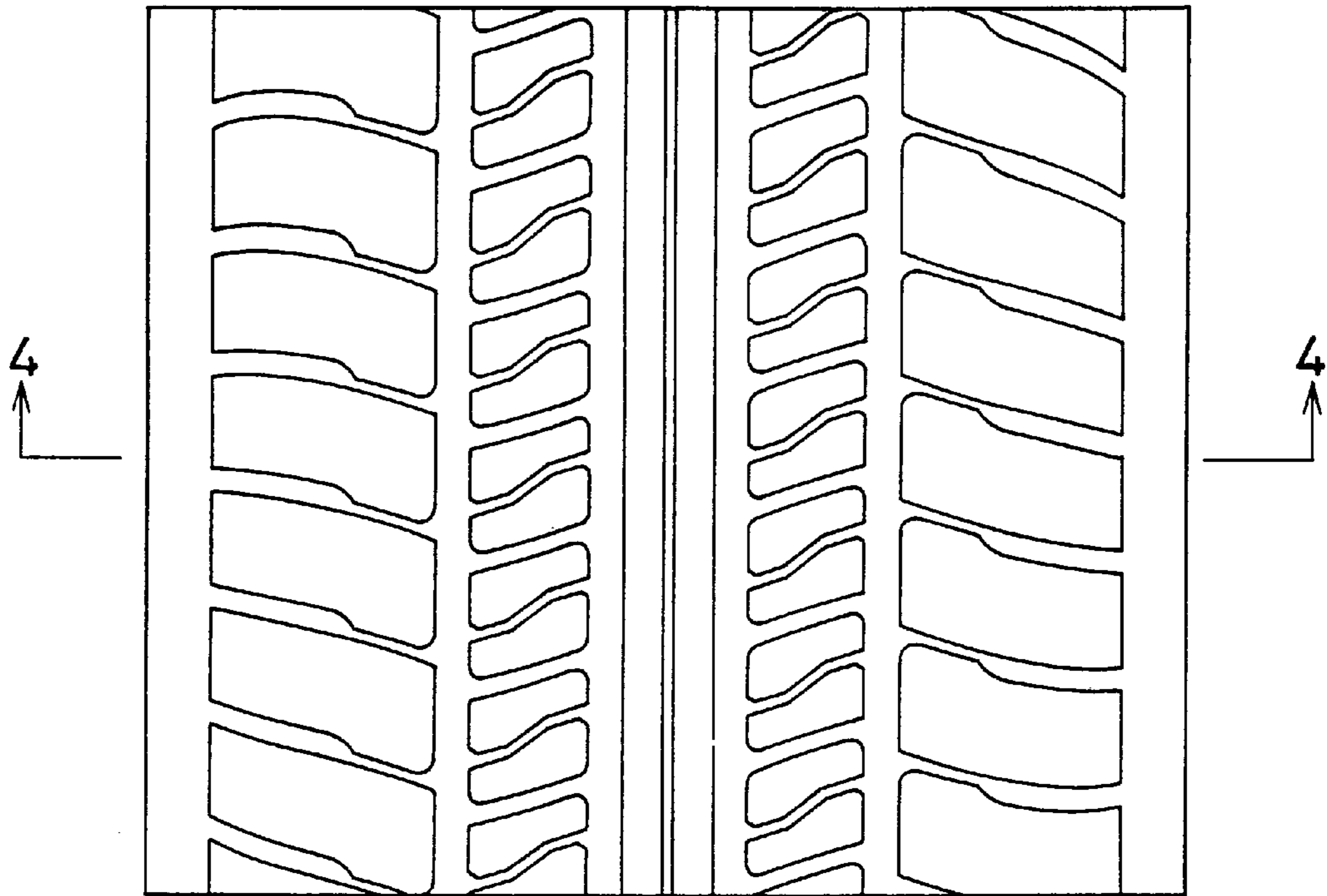
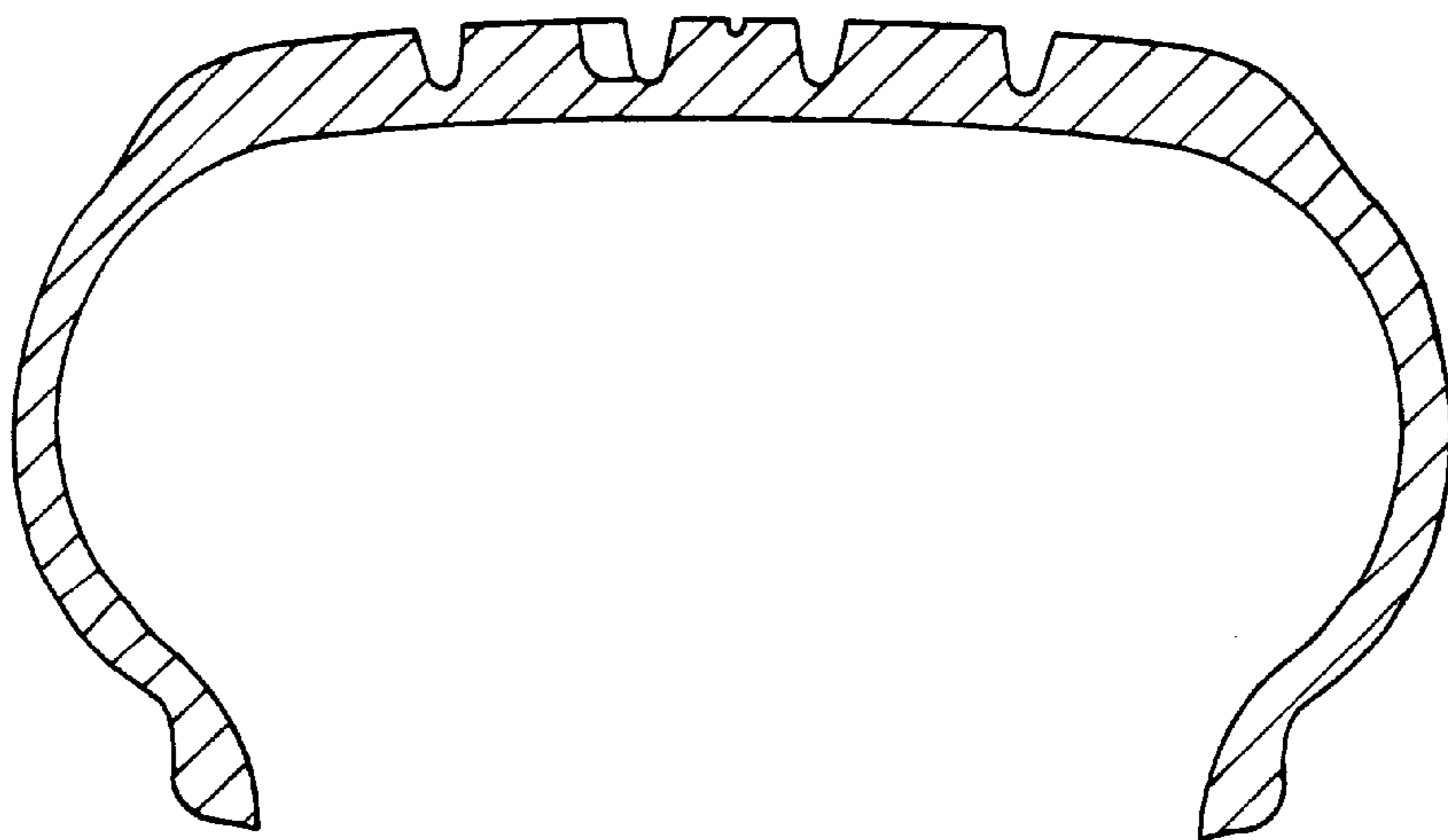

FIG. 4





UNITED STATES PATENT AND TRADEMARK OFFICE  
**CERTIFICATE OF CORRECTION**

PATENT NO. : Des. 410,602

DATED : June 8, 1999

INVENTOR(S) : Matsuda

It is certified that error appears in the above-identified patent and that said Letters Patent is hereby corrected as shown below:

Item [75], delete "Kanawaga-ken", insert therefor

-- Kanagawa-ken --

Signed and Sealed this  
Second Day of November, 1999

*Attest:*



Q. TODD DICKINSON

*Attesting Officer*

*Acting Commissioner of Patents and Trademarks*