



US00D410600S

**United States Patent** [19]  
**Matsuda**

[11] **Patent Number: Des. 410,600**  
[45] **Date of Patent: \*\* Jun. 8, 1999**

[54] **AUTOMOBILE TIRE**

OTHER PUBLICATIONS

[75] Inventor: **Shoichiro Matsuda**, Kanagawa-ken, Japan

Goodyear Eagle RS-A Tire, 1996 Tread Design Guide, p. 34, Feb. 1996.

[73] Assignee: **The Yokohama Rubber Co., Ltd.**, Tokyo, Japan

Road King Grenadier LTE RWL Tire, 1996 Tread Design Guide, p. 63, Feb. 1996.

[\*\*] Term: **14 Years**

*Primary Examiner*—Robert M. Spear  
*Attorney, Agent, or Firm*—Nikaido, Marmelstein, Murray & Oram LLP

[21] Appl. No.: **29/090,708**

[57] **CLAIM**

[22] Filed: **Jul. 14, 1998**

The ornamental design for an automobile tire, as shown and described.

[51] **LOC (6) Cl.** ..... **12-15**

[52] **U.S. Cl.** ..... **D12/146; D12/147**

[58] **Field of Search** ..... D12/136, 138, D12/140-152; 152/209 RR, 209 NS, 209 AS, 209 AG, 209 BY, 209 LG, 209 RB, 209 DP

**DESCRIPTION**

[56] **References Cited**

FIG. 1 is a front view of the automobile tire, showing the new design, each of the rear view, the top plan view and the bottom plan view appearing the same as the front view, it being understood that the tread pattern repeats uniformly throughout the circumference of the tire;

**U.S. PATENT DOCUMENTS**

D. 335,841	5/1993	Caretta et al.	.....	D12/146
D. 350,926	9/1994	Hutz	.....	D12/147
D. 383,422	9/1997	Kunos et al.	.....	D12/147
D. 384,614	10/1997	Hanlon et al.	.....	D12/147
D. 398,890	9/1998	Harpes et al.	.....	D12/147

FIG. 2 is a right side view of the automobile tire, the left side view appearing the same as the right side view;

**FOREIGN PATENT DOCUMENTS**

M 94 04 599 10/1994 Germany .

FIG. 3 is an enlarged fragmentary front view, showing in enlargement the portion of 3—3 in FIG. 1; and,

FIG. 4 is an enlarged sectional view, taken on line 4—4 and in the direction of arrows in FIG. 3.

**1 Claim, 3 Drawing Sheets**

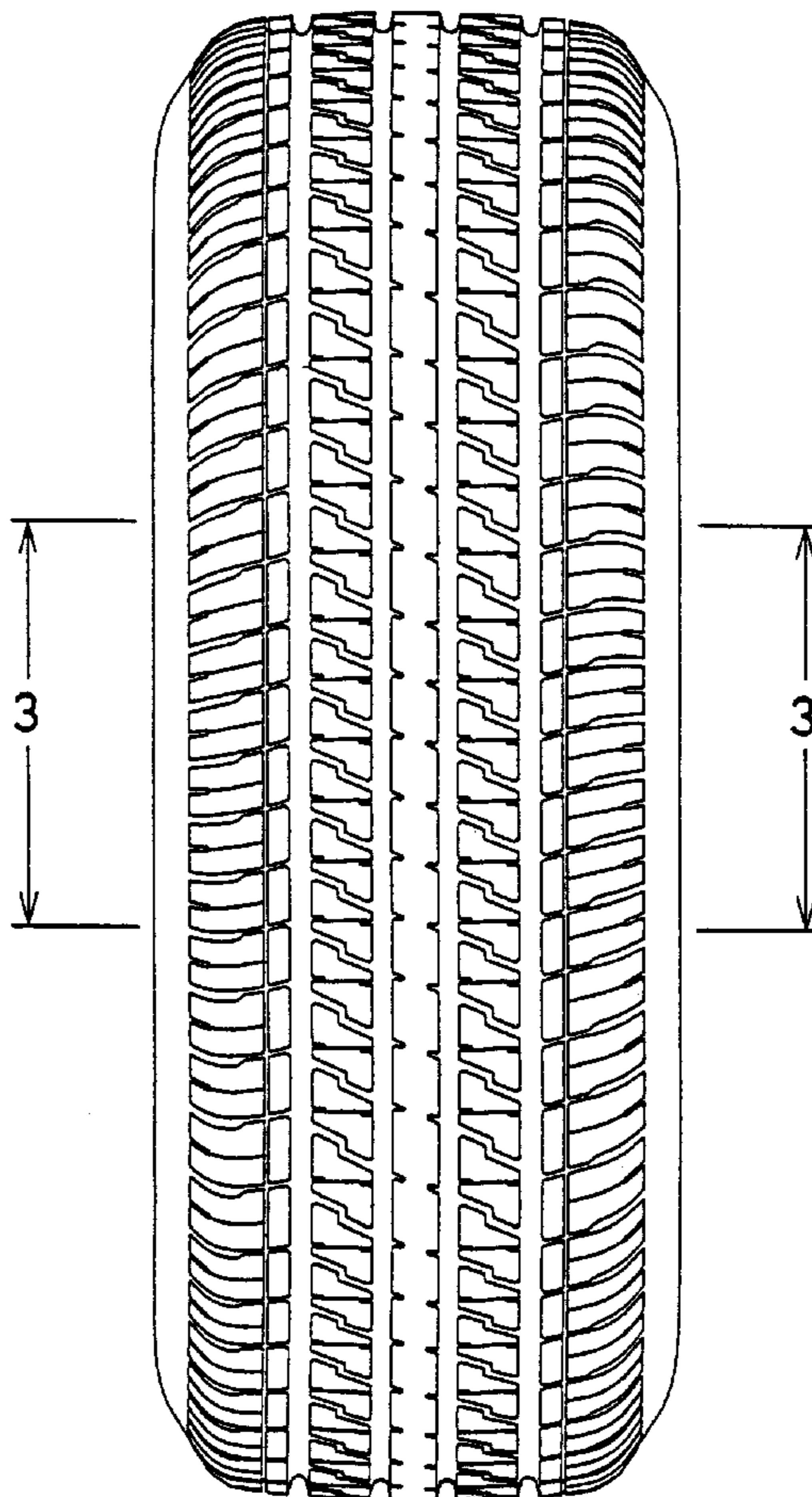

FIG. 1

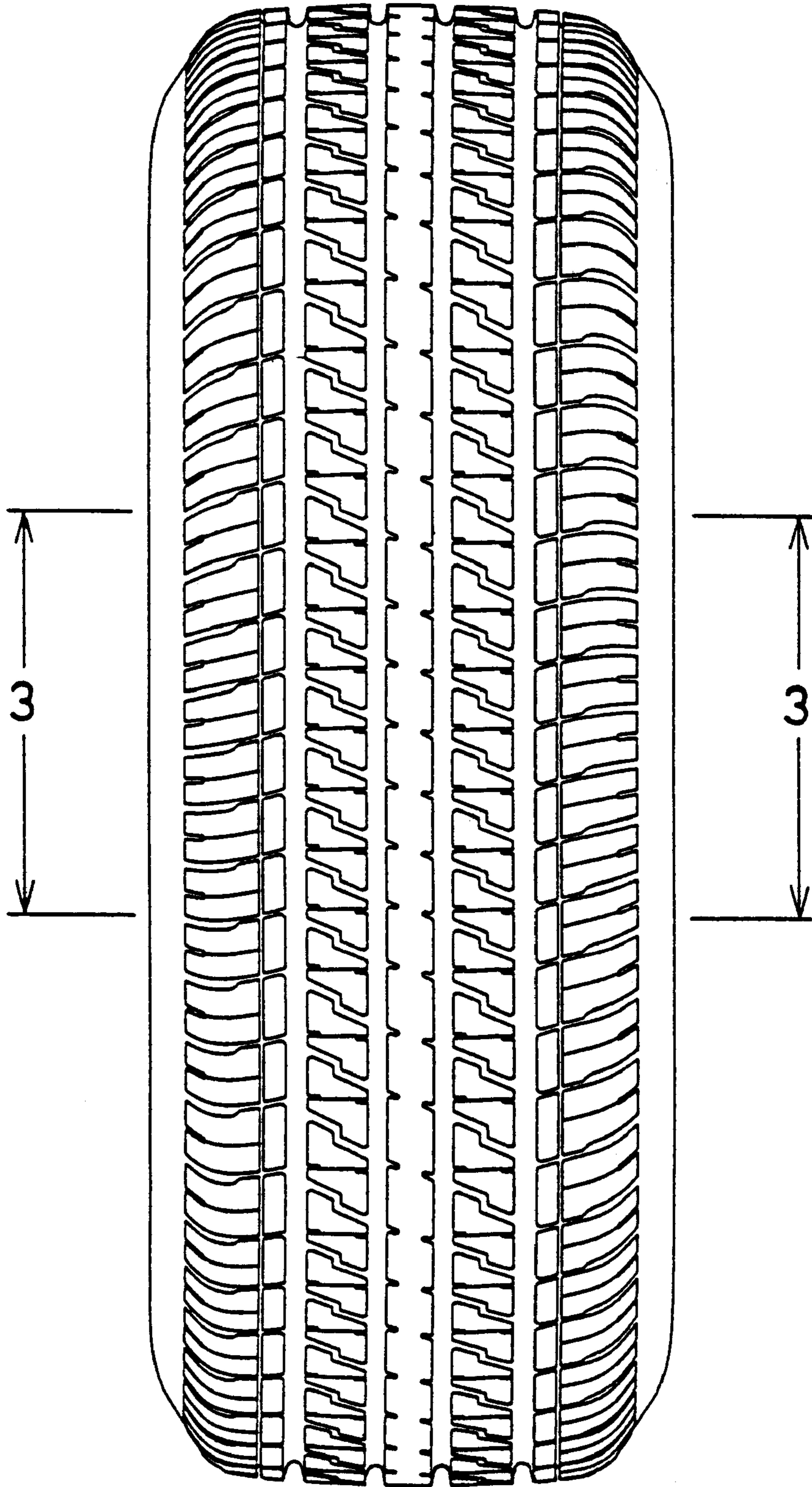

FIG. 2

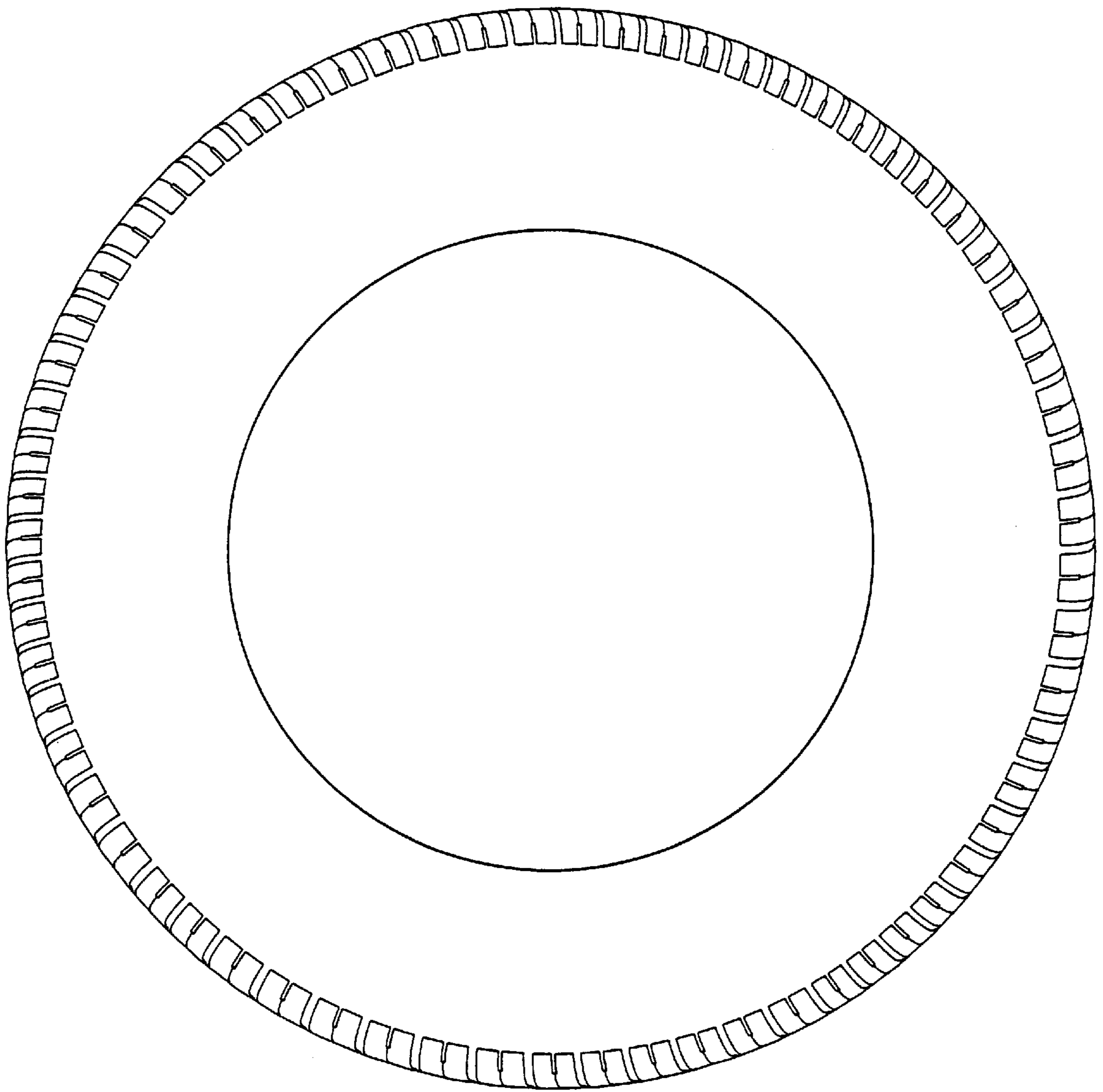

FIG. 3

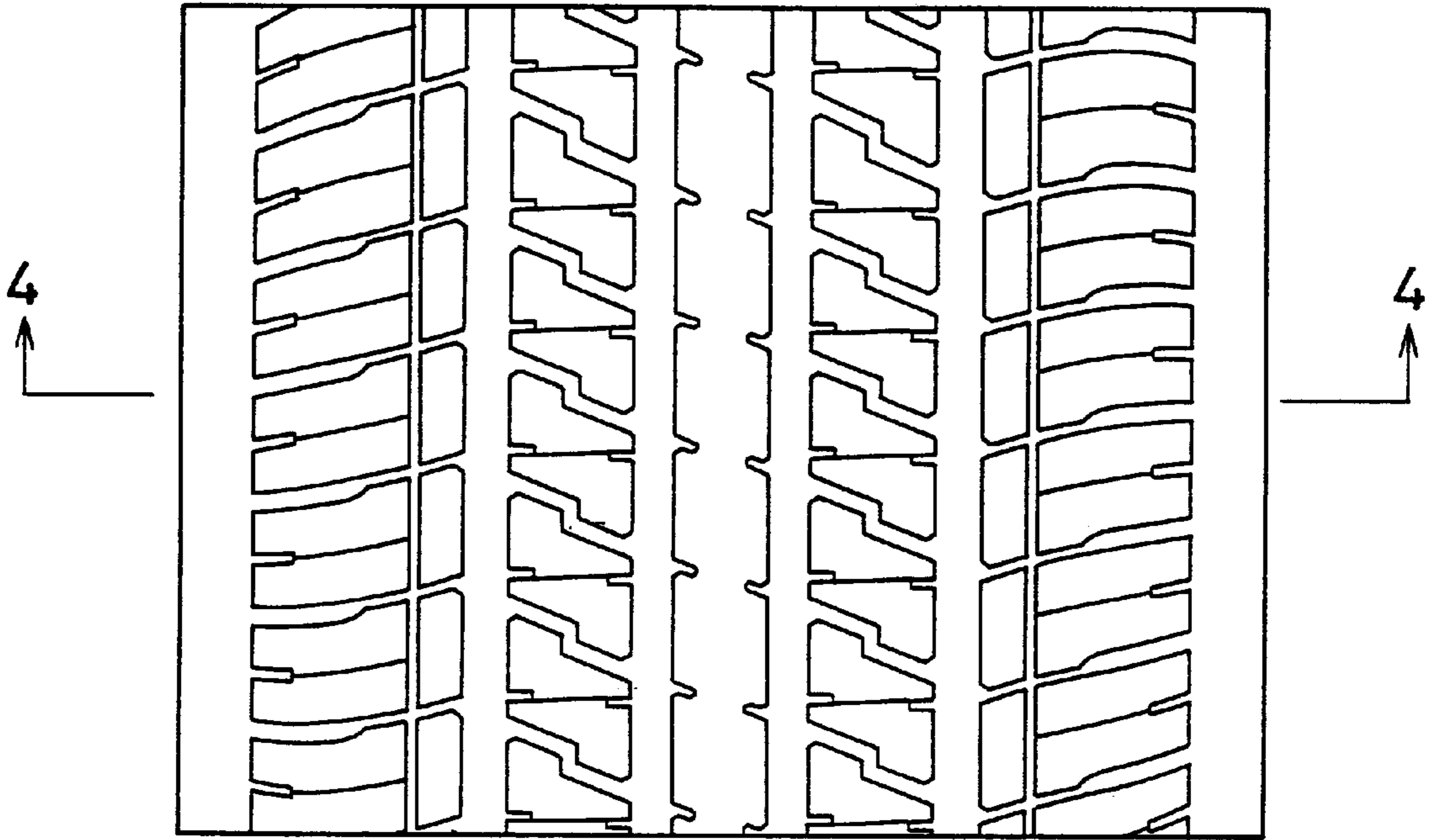

FIG. 4

