



US00D410516S

United States Patent [19] Hyser

[11] Patent Number: Des. 410,516

[45] Date of Patent: ** Jun. 1, 1999

[54] IN-LINE SKATE FRAME

[75] Inventor: Thomas J. Hyser, Seattle, Wash.

[73] Assignee: K-2 Corporation, Vashon, Wash.

[**] Term: 14 Years

[21] Appl. No.: 29/082,533

[22] Filed: Jan. 23, 1998

[51] LOC (6) Cl. 21-02

[52] U.S. Cl. D21/772

[58] Field of Search D21/760, 761,
D21/762, 763, 764, 771, 772; 280/11.19,
11.2, 11.22, 11.23, 11.27

[56] **References Cited**

U.S. PATENT DOCUMENTS

D. 232,044	7/1974	King	D21/761
D. 301,908	6/1989	Olson et al.	D21/226
D. 321,393	11/1991	Olson et al.	D21/226
D. 323,540	1/1992	Graham	D21/225
D. 324,713	3/1992	Rubin	D21/226
D. 334,225	3/1993	Graham	D21/226
D. 344,119	2/1994	Johnson et al.	D21/226
D. 355,690	2/1995	Meibock et al.	D21/220
D. 376,185	12/1996	Berndorfer	D21/772
D. 377,510	1/1997	Berndorfer et al.	D21/772
916,289	3/1909	Fitzgerald .	
2,048,916	7/1936	Bentzlin .	
2,220,557	11/1940	User	280/11.22
2,644,692	7/1953	Kahlert	280/11.22
3,823,952	7/1974	Kukulowicz	280/11.2
3,829,111	8/1974	Nicholls	280/11.3
3,900,203	8/1975	Kukulowicz	280/11.2
4,108,450	8/1978	Coté	280/7.13
4,273,345	6/1981	Ben-Dor et al.	280/11.2

4,295,655	10/1981	Landay et al.	280/11.2
4,711,458	12/1987	Shim	280/11.22
5,046,746	9/1991	Gierveld	280/11.22
5,257,795	11/1993	Babcock	280/11.2
5,342,070	8/1994	Miller et al.	280/11.22
5,380,020	1/1995	Arney et al.	280/11.22
5,397,141	3/1995	Hoshizaki et al.	280/11.3
5,437,466	8/1995	Meibock et al.	280/11.22
5,470,085	11/1995	Meibock et al.	280/11.2
5,472,218	12/1995	Pratt	280/11.2
5,482,301	1/1996	Babcock	280/11.2
5,484,164	1/1996	McInerney et al.	280/11.2
5,505,470	4/1996	Hoshizaki	280/11.22

FOREIGN PATENT DOCUMENTS

0 774 218 A1	5/1997	European Pat. Off. .
2 691 909	12/1993	France .

Primary Examiner—Sandra L. Morris
Attorney, Agent, or Firm—Christensen O'Connor Johnson
& Kindness PLLC

[57] **CLAIM**

The ornamental design for an in-line skate frame, as shown and described.

DESCRIPTION

FIG. 1 provides a perspective view of an in-line skate frame showing my new design; FIG. 2 provides a side elevation view thereof, the opposite side not shown being substantially identical; and, FIGS. 3, 4 and 5 are bottom plan, front and rear elevation views thereof, respectively. The broken line showing of a skate boot and wheels in FIG. 2 are for illustration purposes only and are not part of the claimed design.

1 Claim, 2 Drawing Sheets

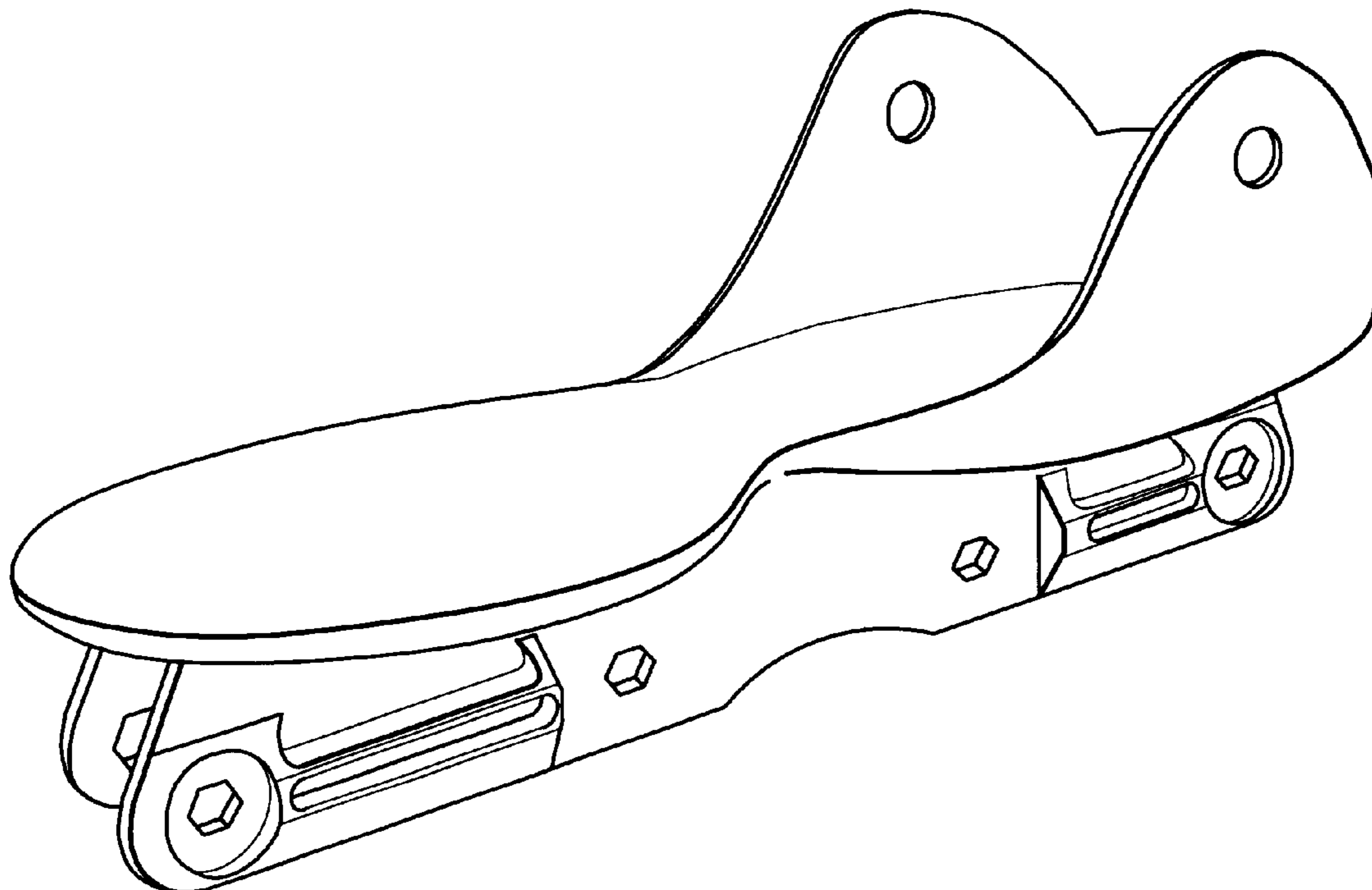

Fig. 1.

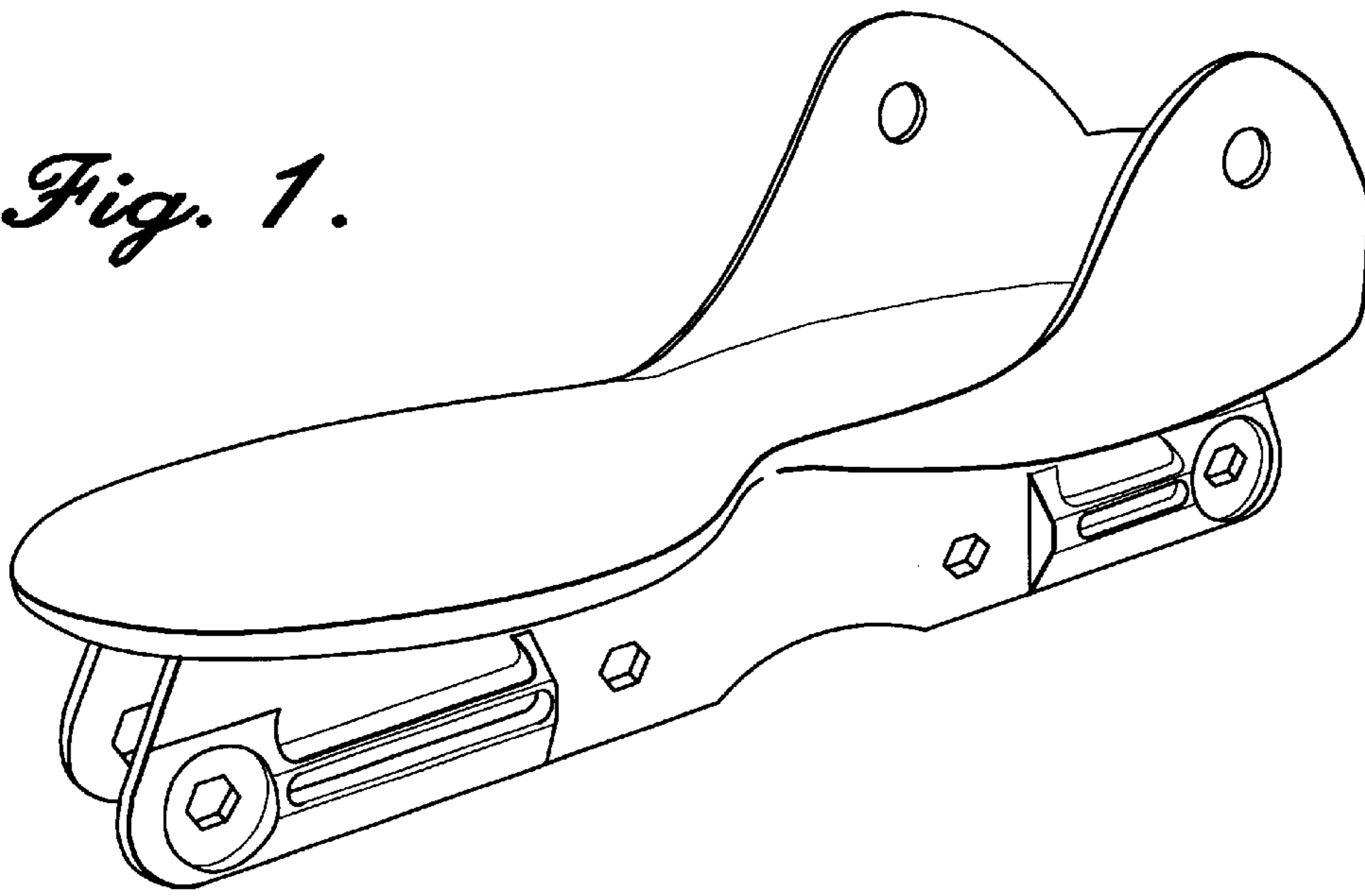
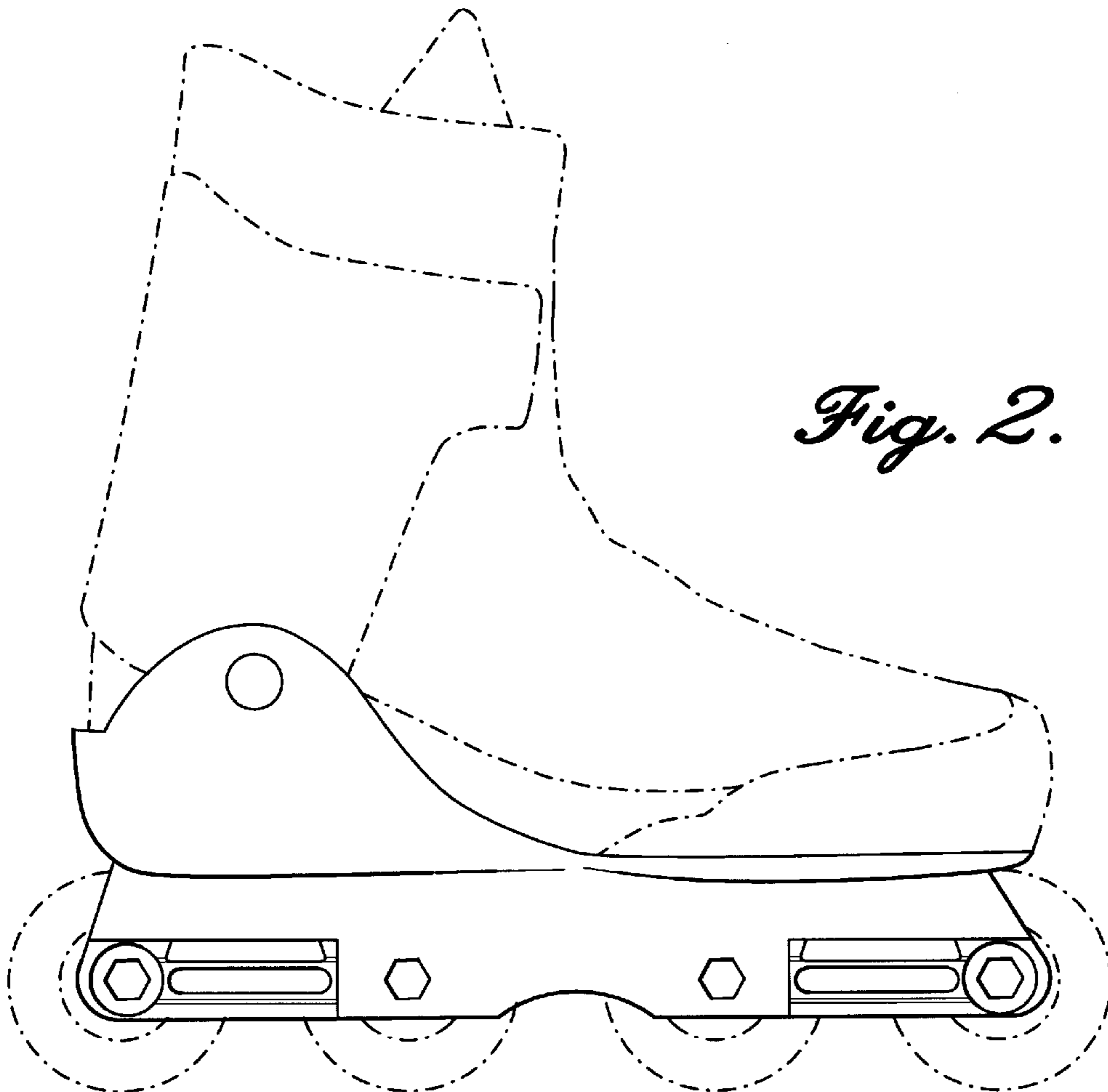

Fig. 2.



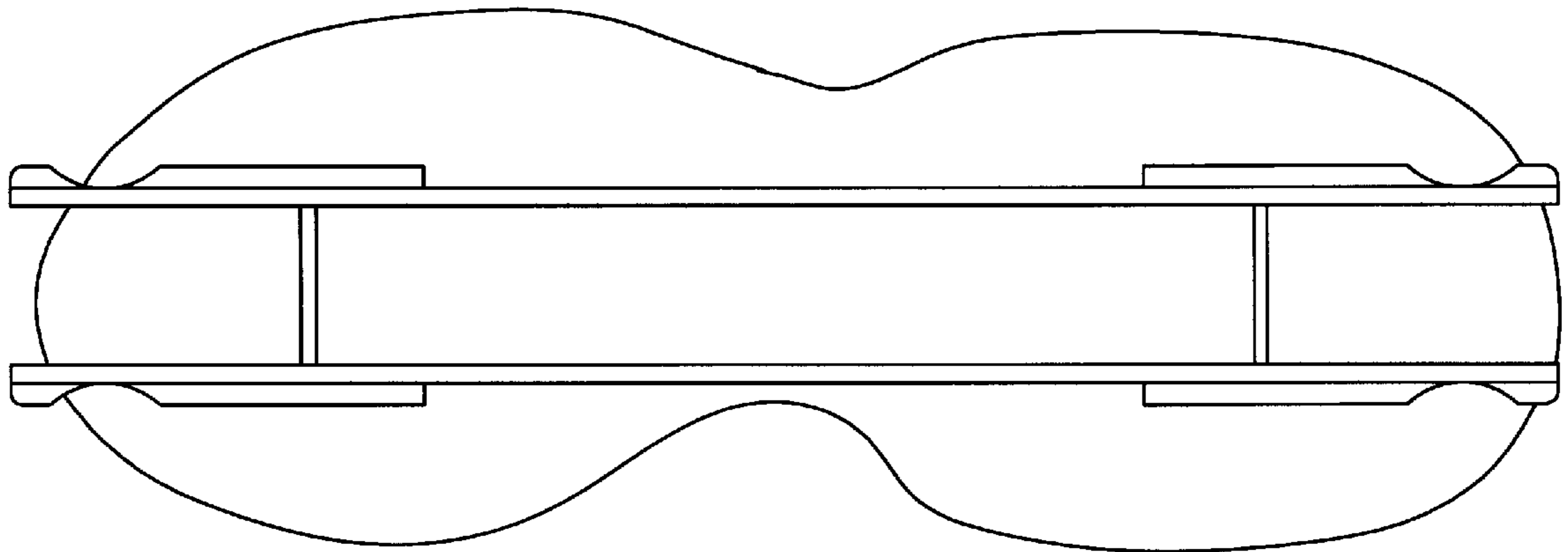

Fig. 3.

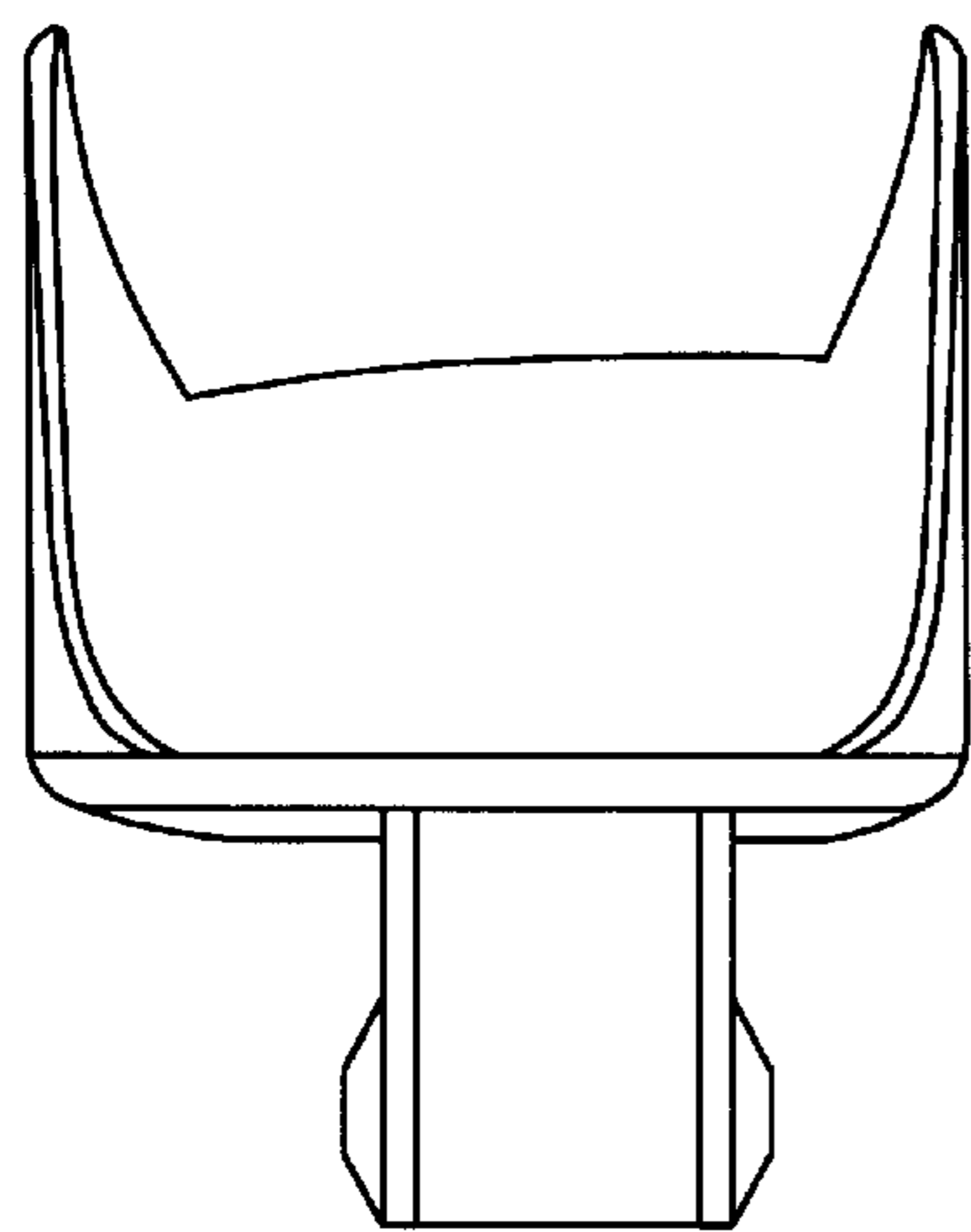

Fig. 4.

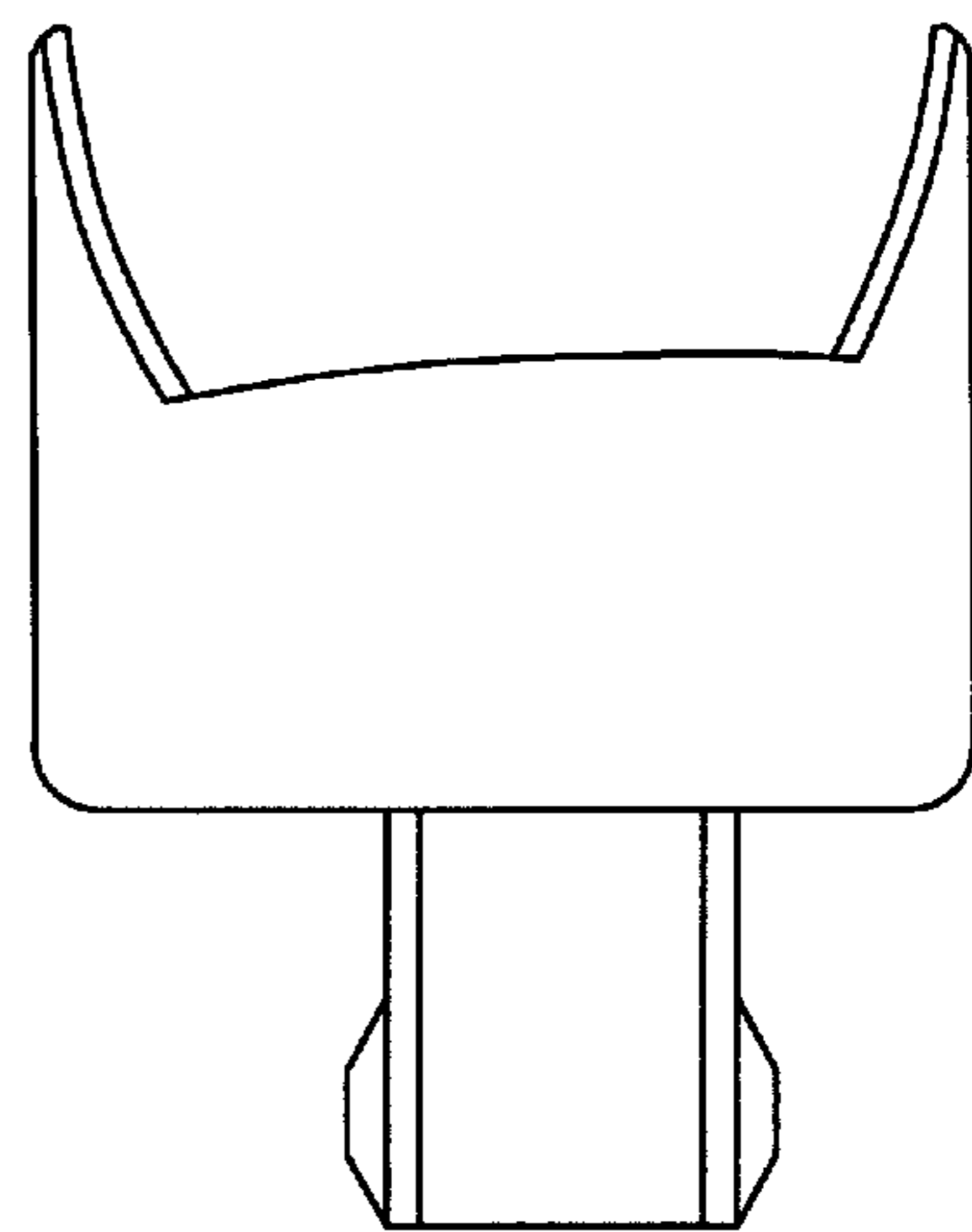

Fig. 5.