



US00D410224S

United States Patent [19] Landy

[11] **Patent Number: Des. 410,224**

[45] **Date of Patent: ** May 25, 1999**

[54] **ROOFTOP CARGO BAG**

[75] Inventor: **Richard Landy**, Castaic, Calif.

[73] Assignee: **Quaker State Investment Corporation**, Wilmington, Del.

[**] Term: **14 Years**

[21] Appl. No.: **29/057,153**

[22] Filed: **Jul. 17, 1996**

[51] **LOC (6) Cl.** **12-16**

[52] **U.S. Cl.** **D12/413**

[58] **Field of Search** D12/406, 412-414;
224/323, 328

[56] **References Cited**

U.S. PATENT DOCUMENTS

| | | | | |
|------------|---------|-----------|-------|-----------|
| D. 276,329 | 11/1984 | Nepper | | D12/413 |
| D. 309,214 | 7/1990 | Haugland | | D12/413 |
| D. 317,429 | 6/1991 | Seaver | | D12/413 |
| D. 319,422 | 8/1991 | Tyner | | D12/413 |
| 2,440,821 | 5/1948 | Godwin | | 224/328 |
| 2,454,608 | 11/1948 | Meyerdick | | 224/328 |
| 2,621,836 | 12/1952 | McMiller | | 224/323 |
| 3,141,588 | 7/1964 | McMiller | | 224/323 |
| 3,153,501 | 10/1964 | Binding | | 224/328 |
| 3,955,732 | 5/1976 | Boschen | | 224/328 X |

| | | | | |
|-----------|---------|-----------|-------|-----------|
| 4,050,614 | 9/1977 | Simpson | | 224/328 X |
| 4,779,779 | 10/1988 | Haugland | | 224/328 |
| 5,096,107 | 3/1992 | Vanson | | 224/328 |
| 5,288,003 | 2/1994 | MacDonald | | 224/328 |
| 5,538,169 | 7/1996 | Moore | | 224/328 |

Primary Examiner—Doris V. Coles
Assistant Examiner—Stacia Sinuik
Attorney, Agent, or Firm—Jenkins & Gilchrist

[57] **CLAIM**

The ornamental design for the rooftop cargo bag, as shown and described.

DESCRIPTION

FIG. 1 is a perspective view of a cargo bag of my inventive design, the car top shown is for illustration only and does not form part of the design;

FIG. 2 is an enlarged top plan view of the cargo bag of FIG. 1;

FIG. 3 is an enlarged side view of the cargo bag of FIG. 1, other side views are mirror images of the view shown; and, FIG. 4 is an enlarged bottom plan view of the cargo bag of FIG. 1.

The dashed lines shown on the cargo bag in FIGS. 1 and 3 are intended to represent stitching.

The dashed lines on the rooftop cargo bag are understood to represent stitching.

1 Claim, 4 Drawing Sheets

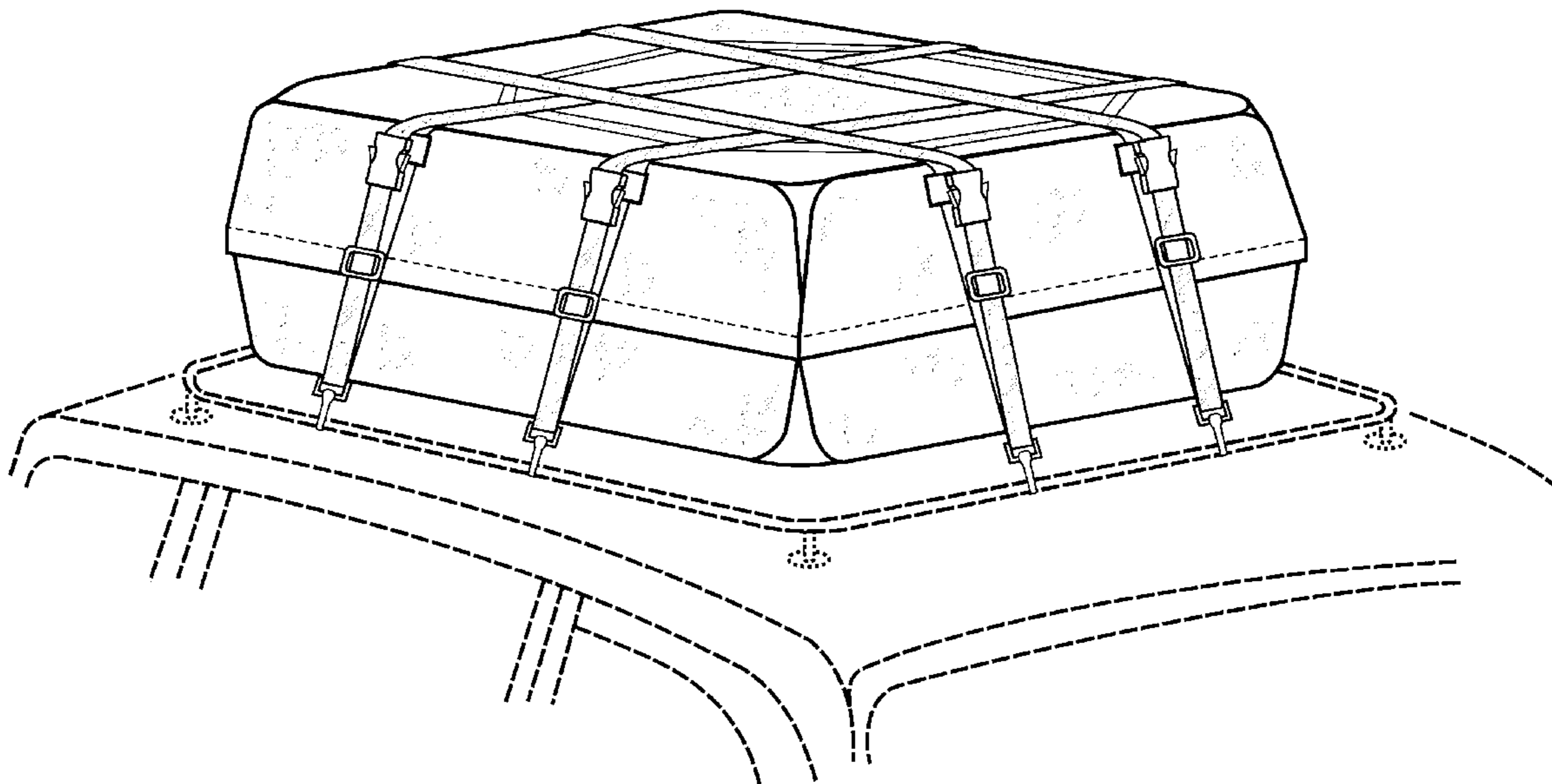

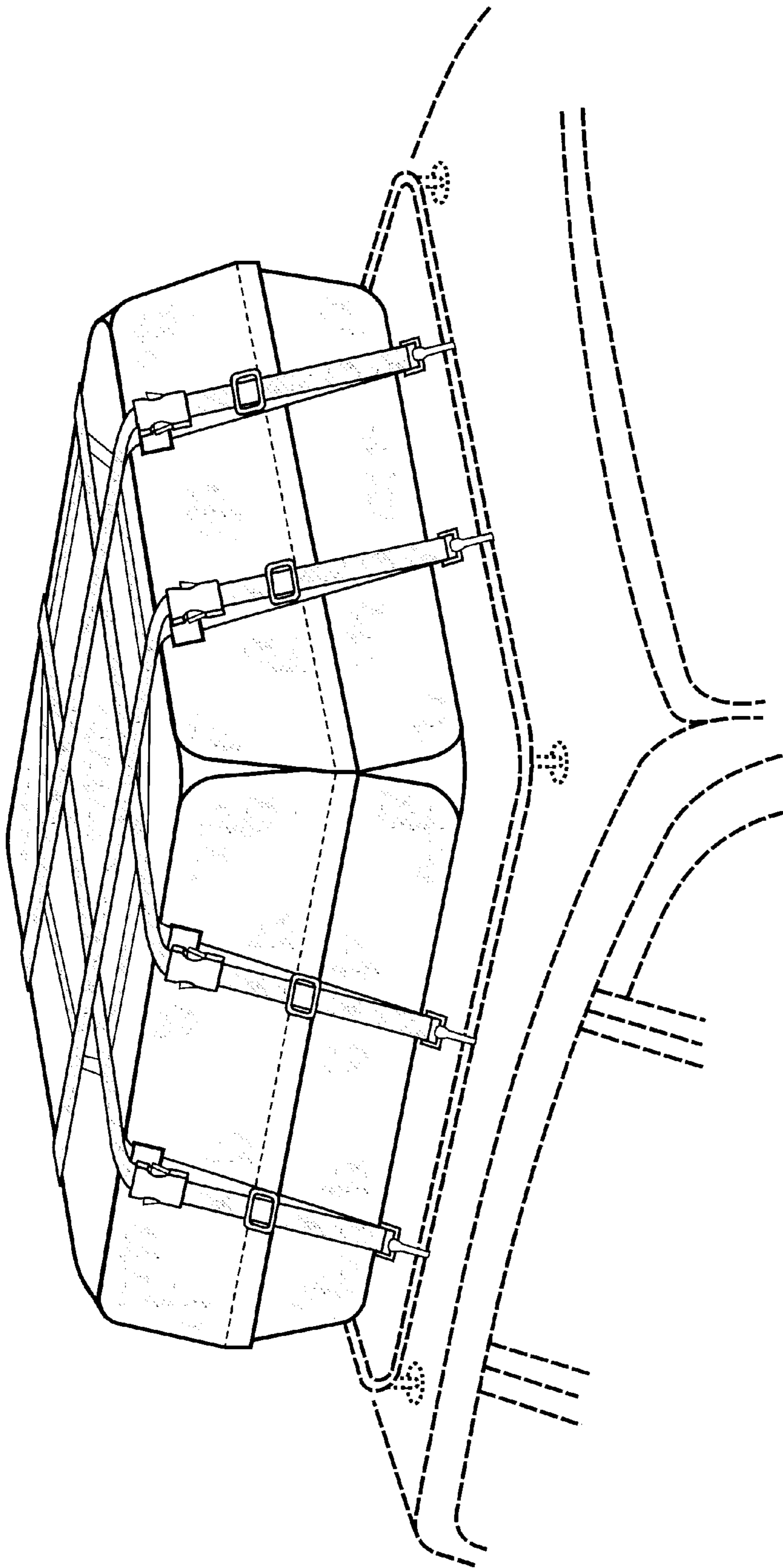

Figure 1

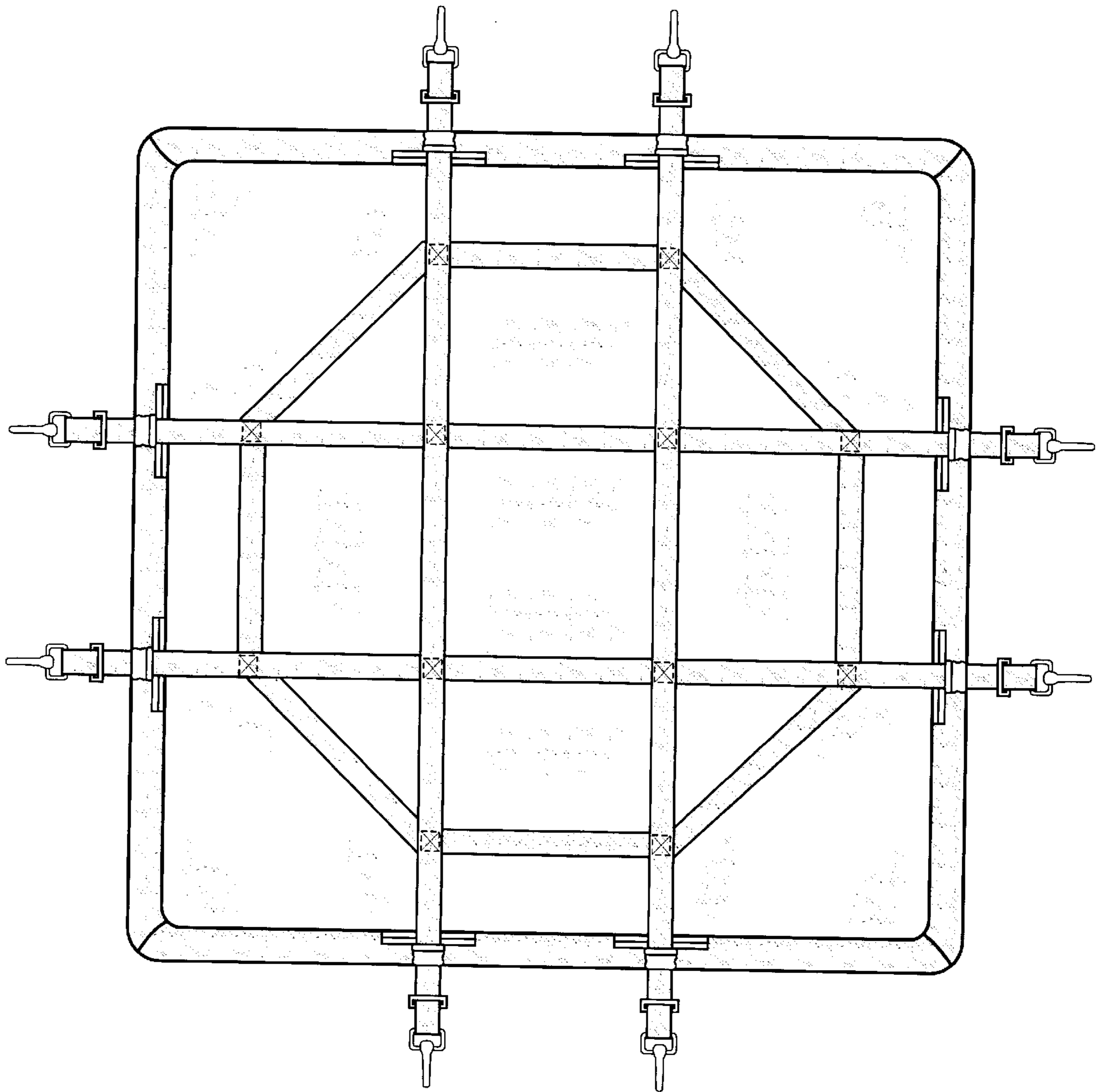

Figure 2

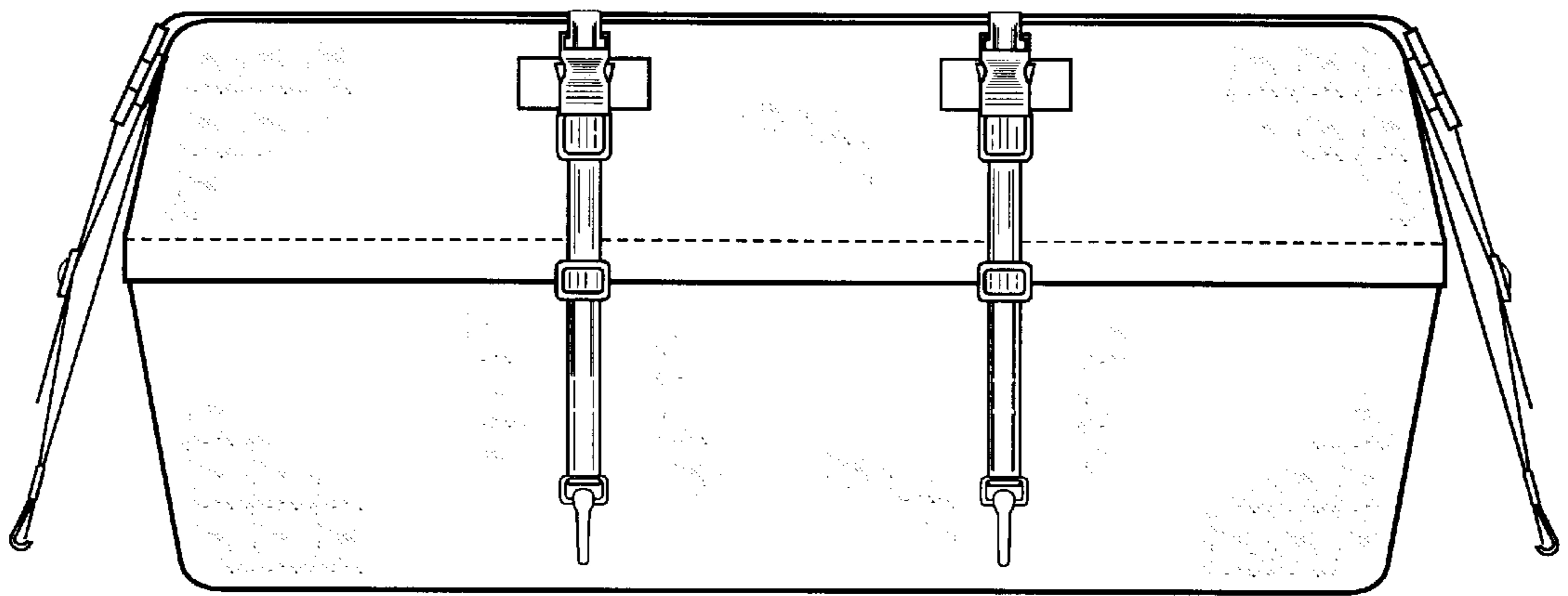

Figure 3

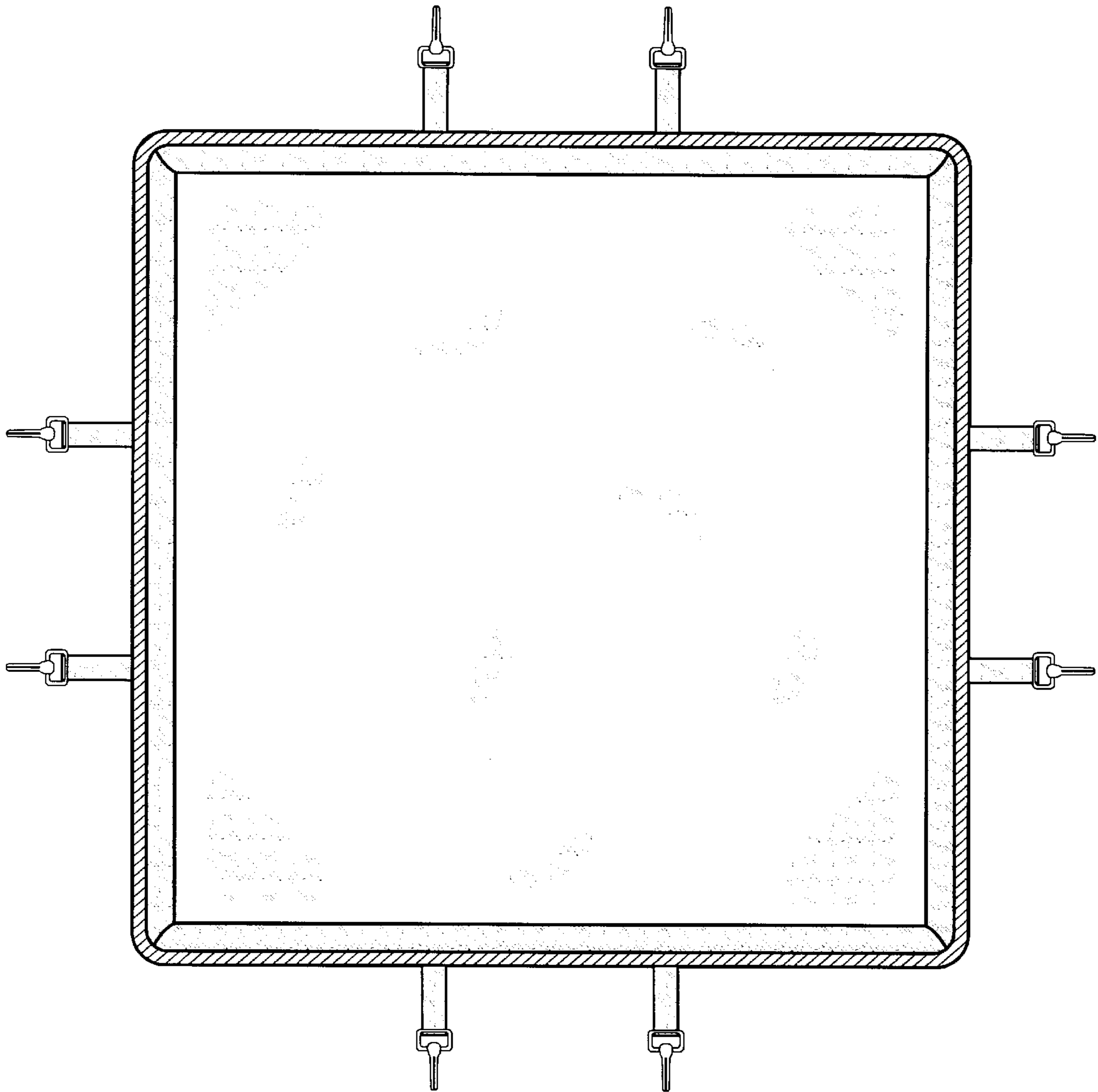

Figure 4