



US00D410223S

United States Patent [19]
Locke

[11] **Patent Number: Des. 410,223**

[45] **Date of Patent: ** May 25, 1999**

[54] **BAGS FOR MOTORCYCLE**

[76] Inventor: **Andrew Norman Locke**, 75 Russell St., Howlong, New South Wales, Australia, 2643

[**] Term: **14 Years**

[21] Appl. No.: **29/089,118**

[22] Filed: **Jun. 8, 1998**

[30] **Foreign Application Priority Data**

Dec. 9, 1997 [AU] Australia 4007/97

[51] **LOC (6) Cl.** **12-16**

[52] **U.S. Cl.** **D12/407; D3/231; 224/609**

[58] **Field of Search** **D12/407-411; 280/288.4; 180/219; 224/609, 413, 429, 430; D3/231, 234, 243; 150/108; 383/7, 38**

[56] **References Cited**

U.S. PATENT DOCUMENTS

D. 234,326	2/1975	Kato	D3/231
D. 350,435	9/1994	Smith, IV	D3/231
1,121,366	12/1914	Hurrell	224/413
3,796,357	3/1974	Johnson	224/429
5,031,807	7/1991	Tiffany	150/108
5,201,442	4/1993	Bakalian	280/288.4
5,350,093	9/1994	Sheely	224/429

Primary Examiner—Pamela Burgess
Attorney, Agent, or Firm—Richard M. Goldberg

[57] **CLAIM**

The ornamental design for bags for motorcycles, as shown and described.

DESCRIPTION

FIG. 1 is a perspective view of one embodiment of the bags in a flat position.

FIG. 2 is a perspective view of the embodiment of FIG. 1 showing the bags in a folded position.

FIG. 3 is a perspective view of the embodiment of FIG. 1 showing the bags in position on a motorcycle. In FIG. 3, the shape of the motorcycle shown in dashed lines forms no part of the design.

FIG. 4 is a perspective view of a second embodiment of the bags in a flat position.

FIG. 5 is a perspective view of the embodiment of FIG. 4 showing the bags in a folded position.

FIG. 6 is a perspective view of the embodiment of FIG. 4 showing the bags in position on a motorcycle. In FIG. 6, the shape of the motorcycle shown in dashed outline forms no part of the design.

FIG. 7 is a top plan view of embodiment 1, FIG. 1;

FIG. 8 is a bottom plan view thereof, with the bags separated for clarity of illustration;

FIG. 9 is a side elevational view of FIG. 8, the undisclosed side being the same;

FIG. 10 is a top plan view of FIG. 8;

FIG. 11 is a bottom plan view of FIG. 4;

FIG. 12 is a side elevational view of FIG. 4, the undisclosed side being a mirror image; and,

FIG. 13 is a top plan view of FIG. 4.

The design is intended to be used for a bag which is draped over a motorcycle.

1 Claim, 4 Drawing Sheets

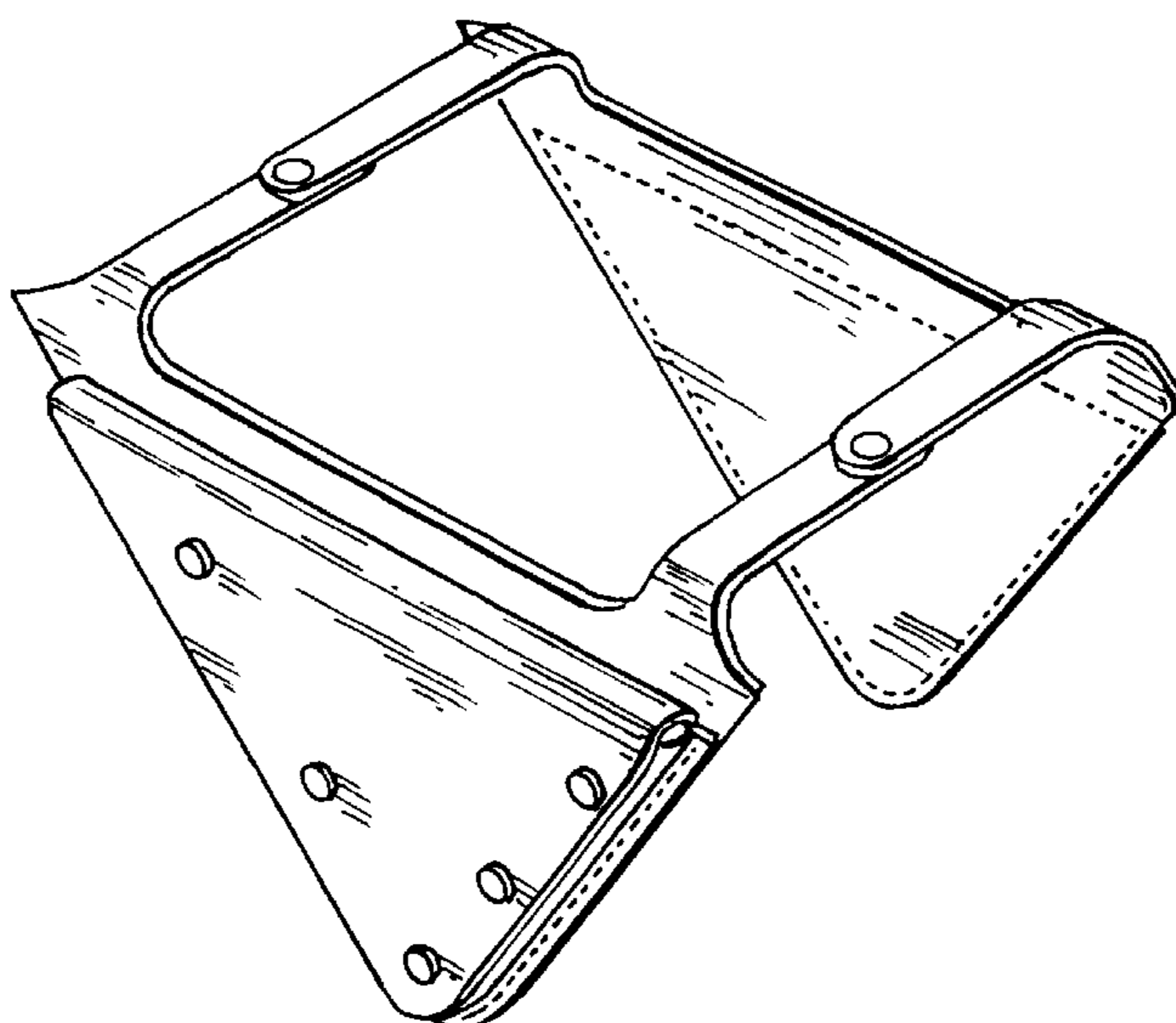

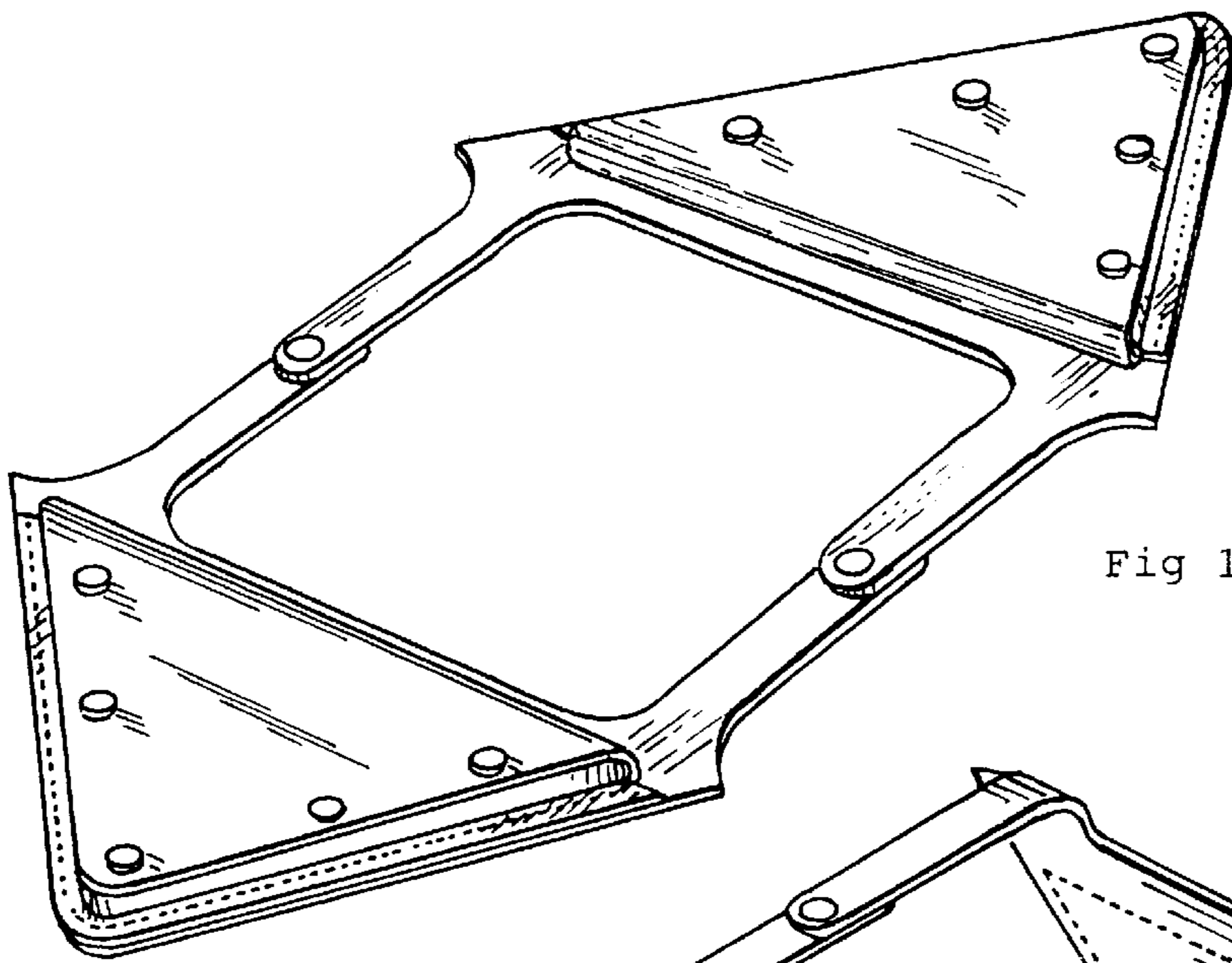

Fig 1

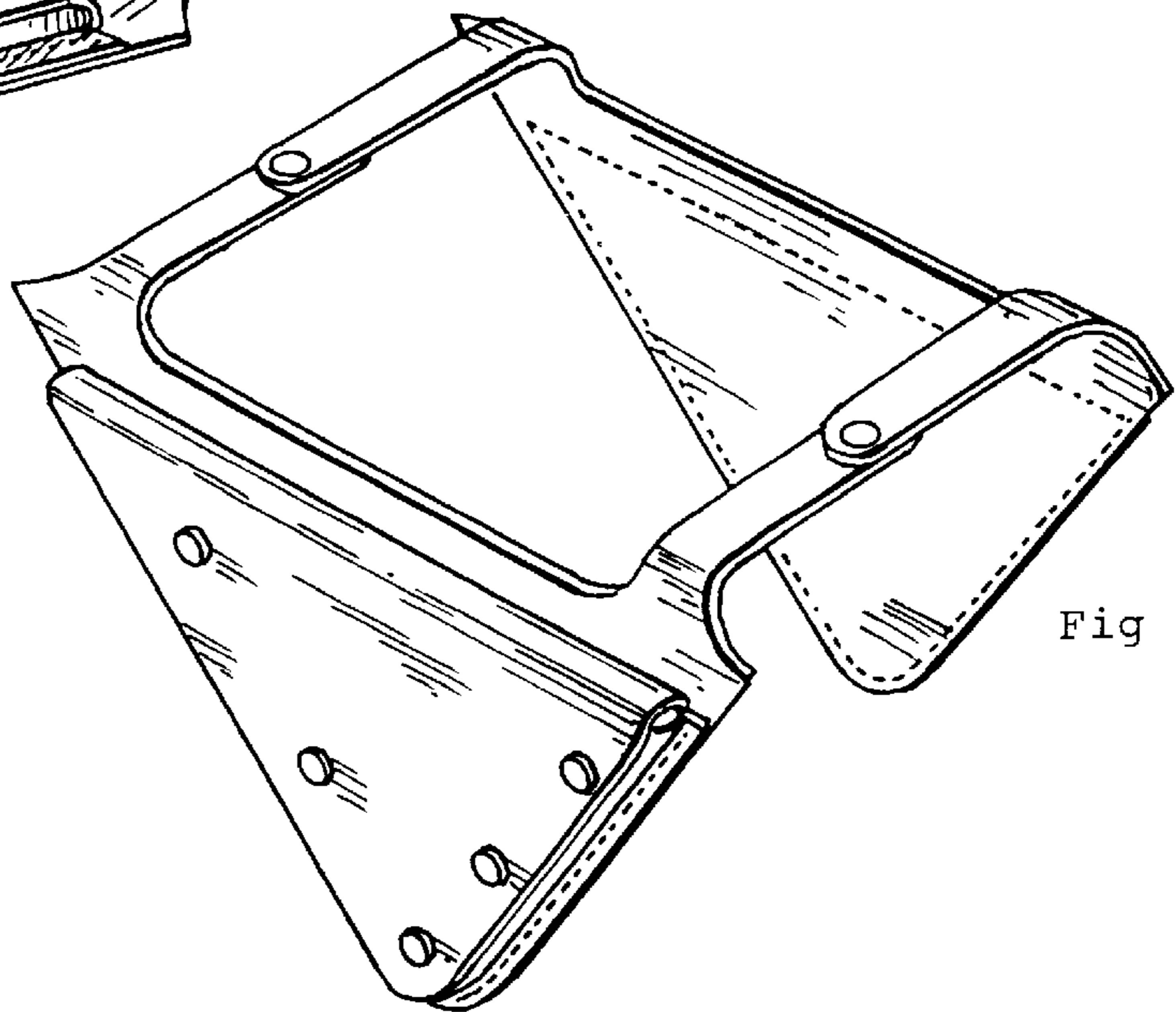

Fig 2

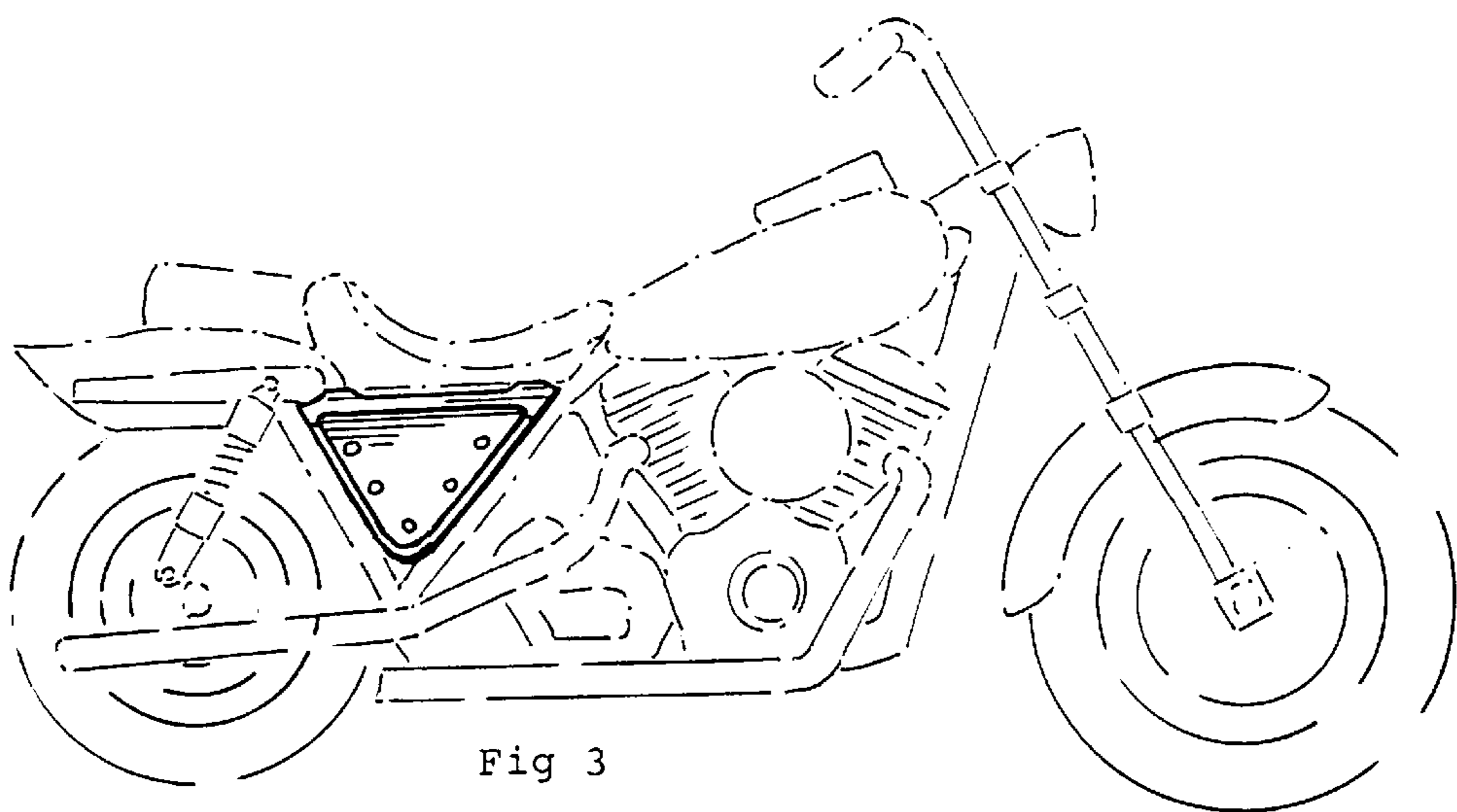

Fig 3

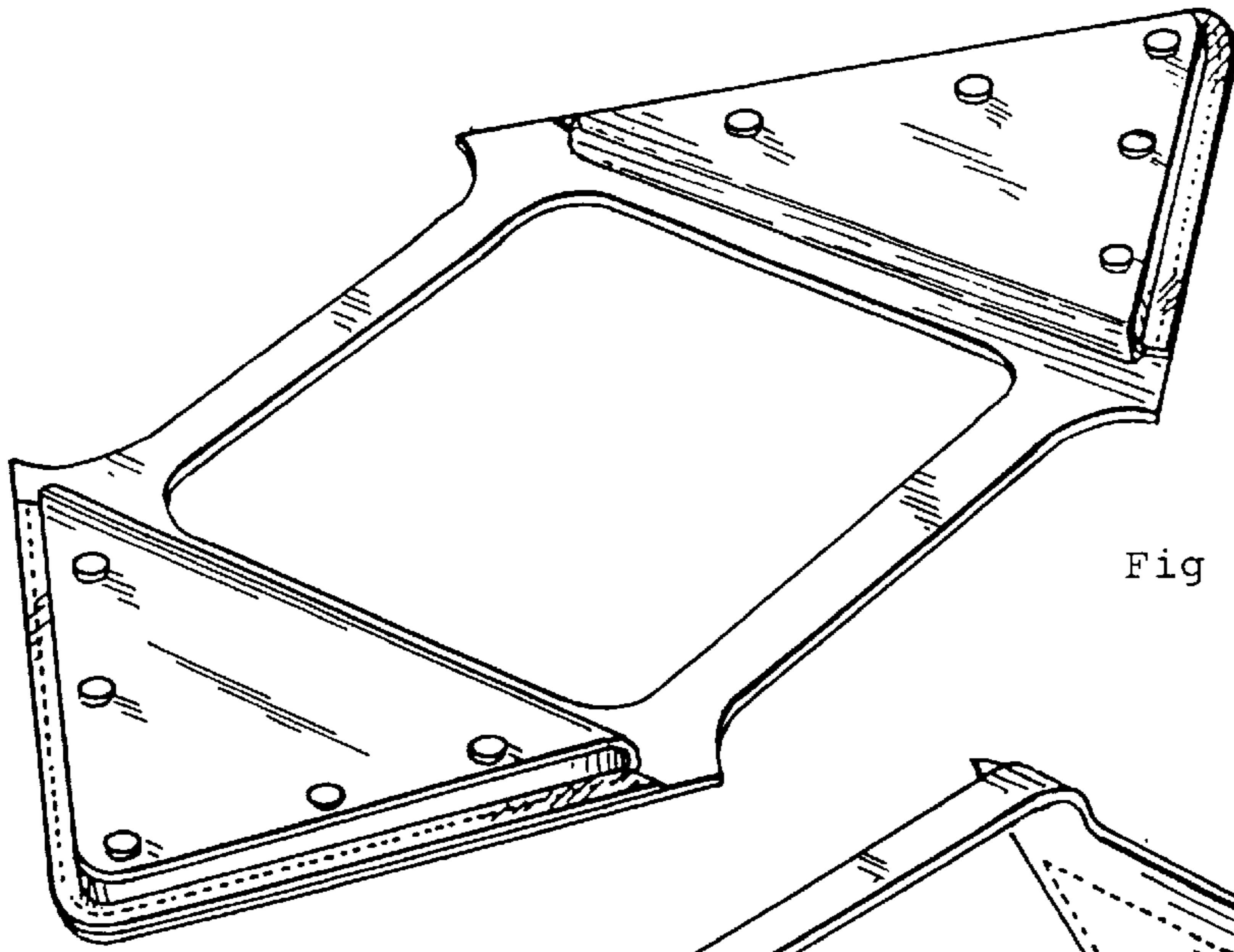

Fig 4

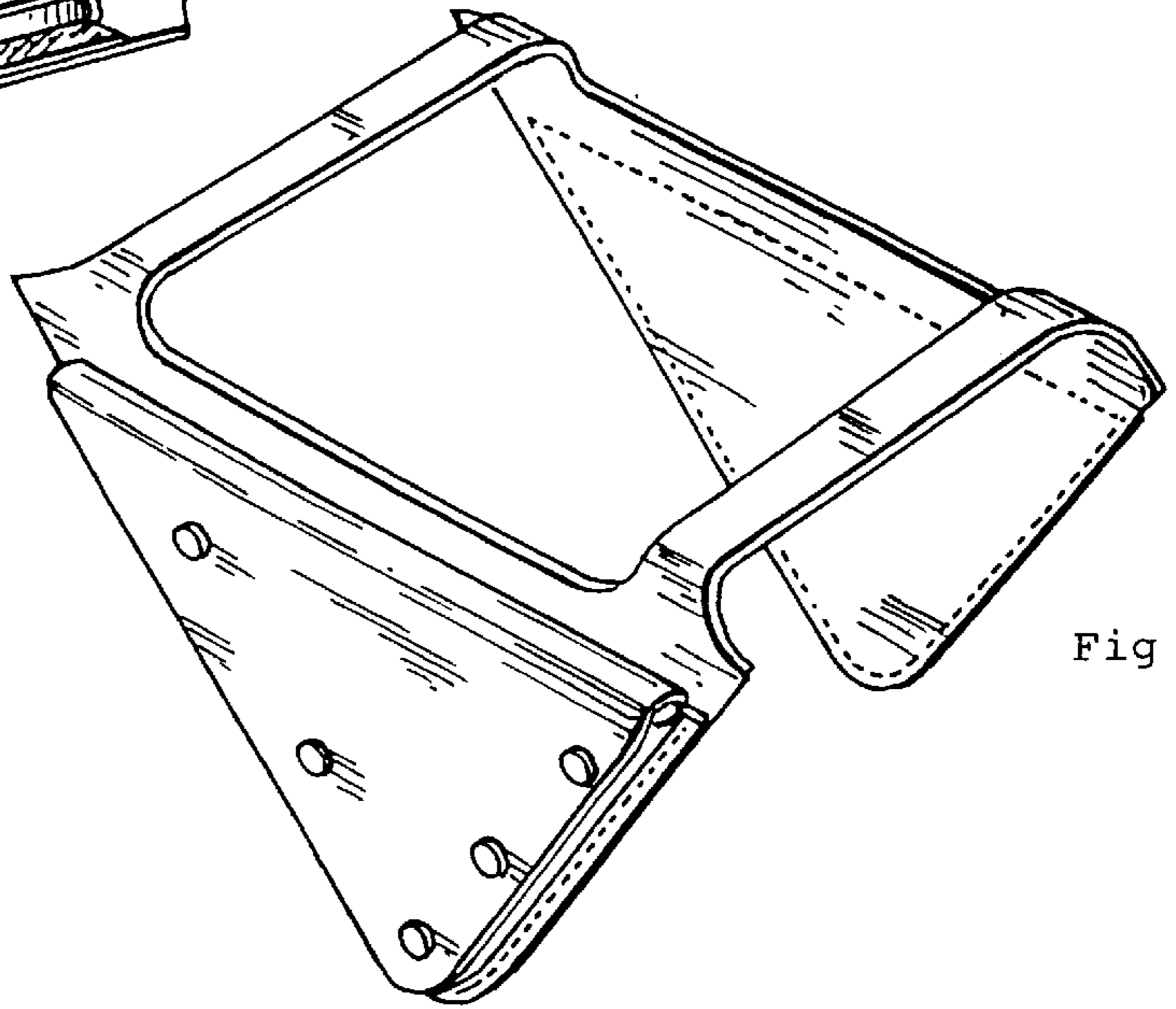

Fig 5

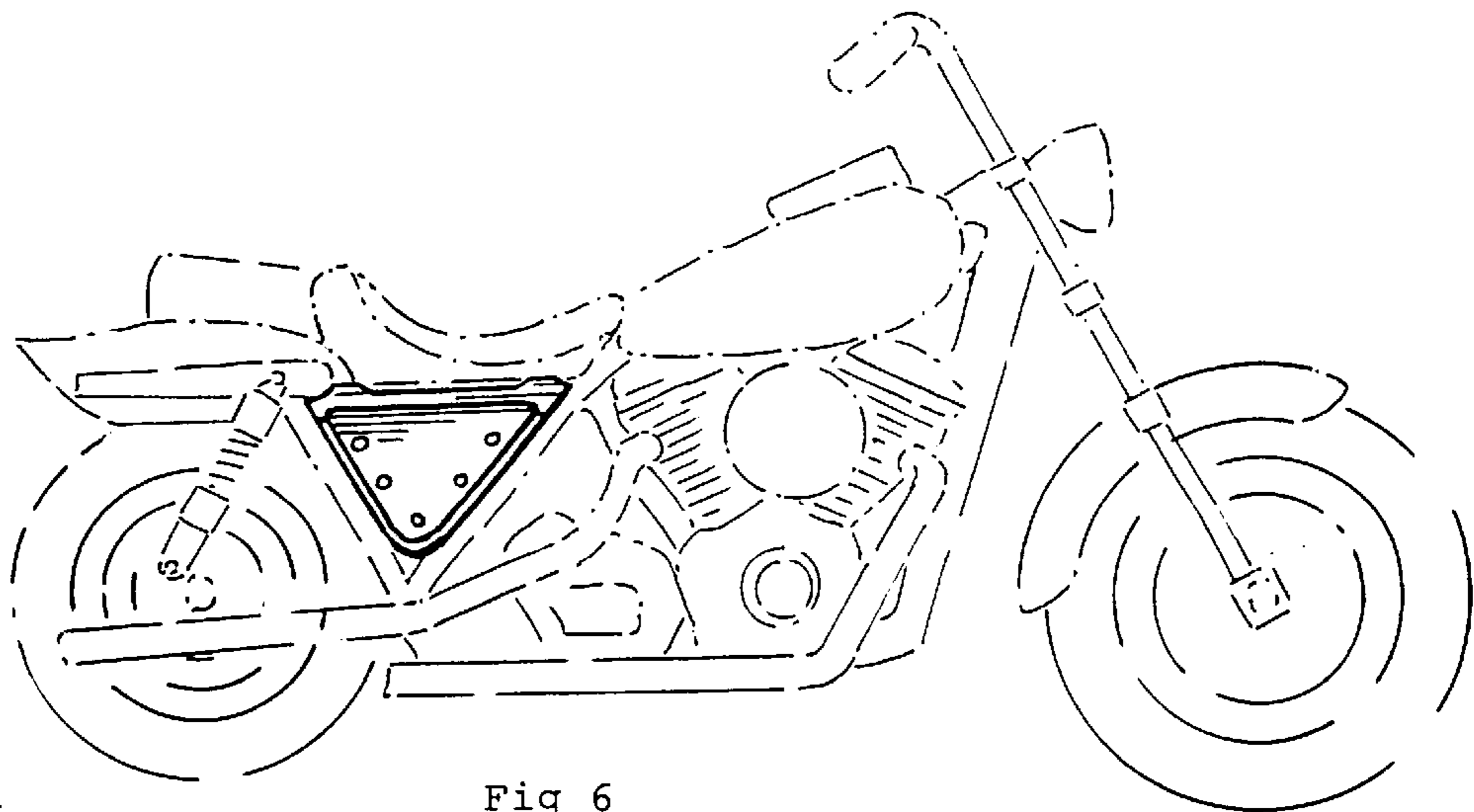

Fig 6

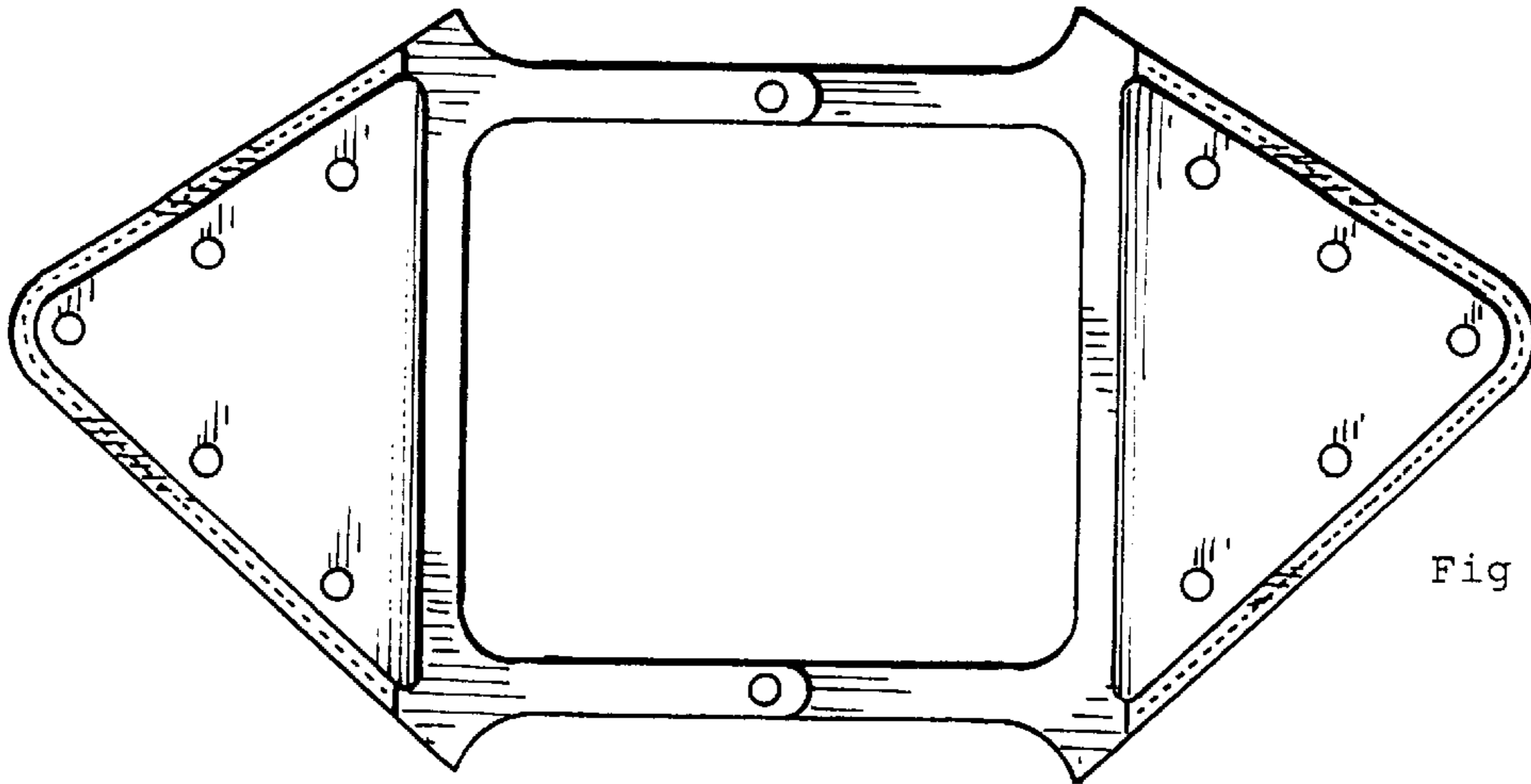

Fig 7

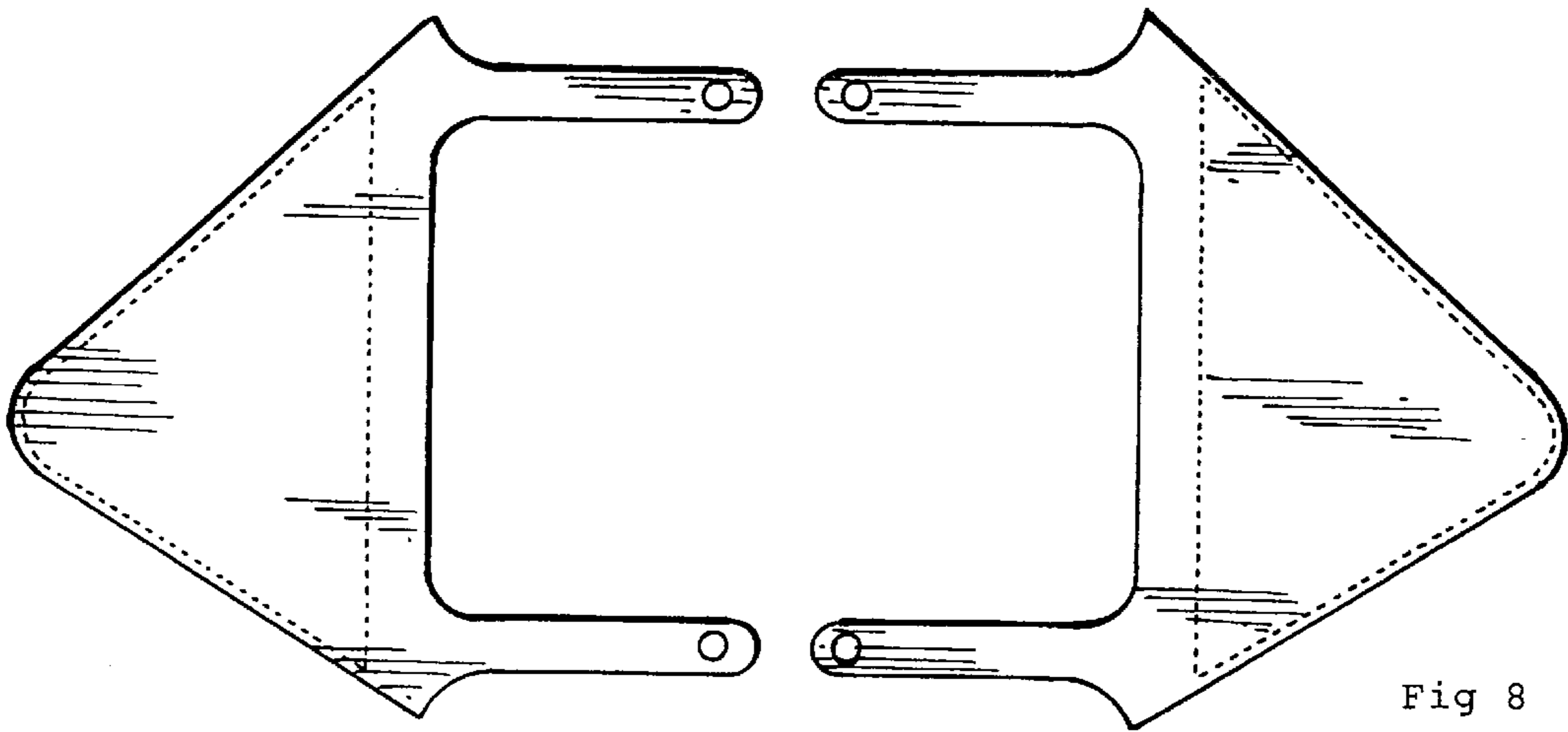

Fig 8



Fig 9

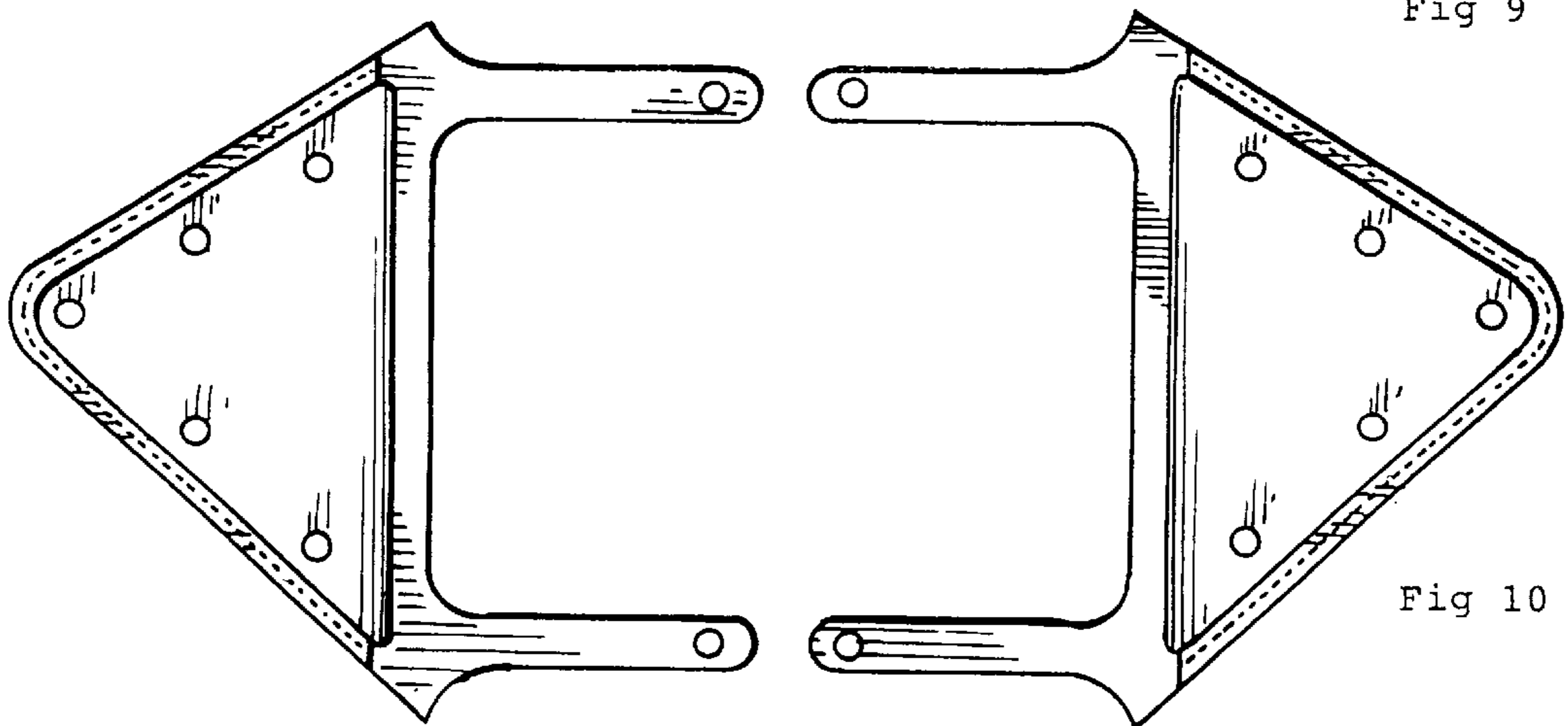

Fig 10

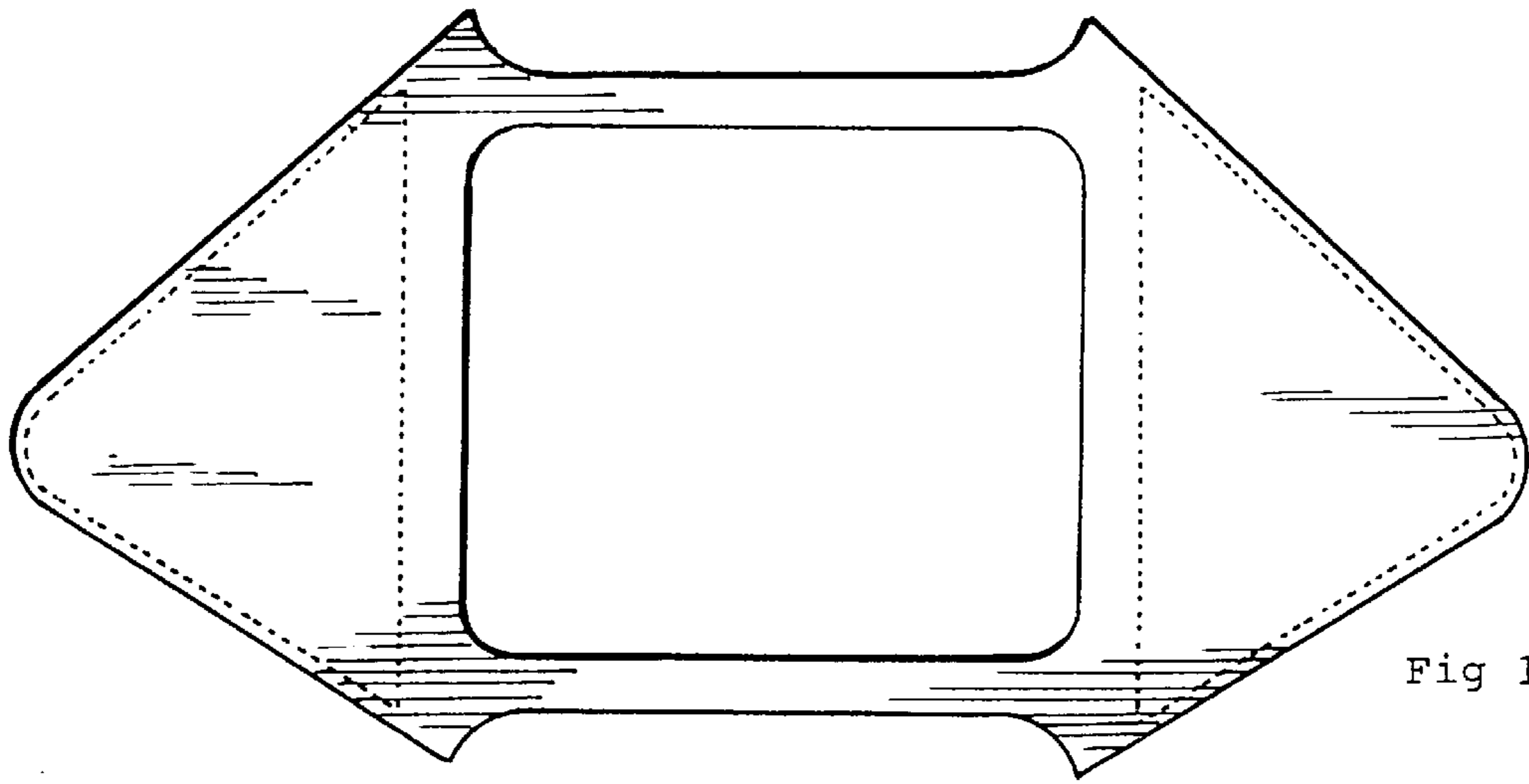

Fig 11

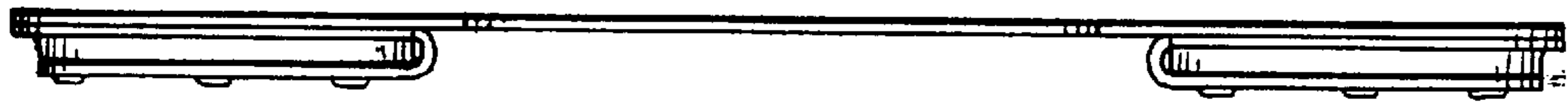

Fig 12

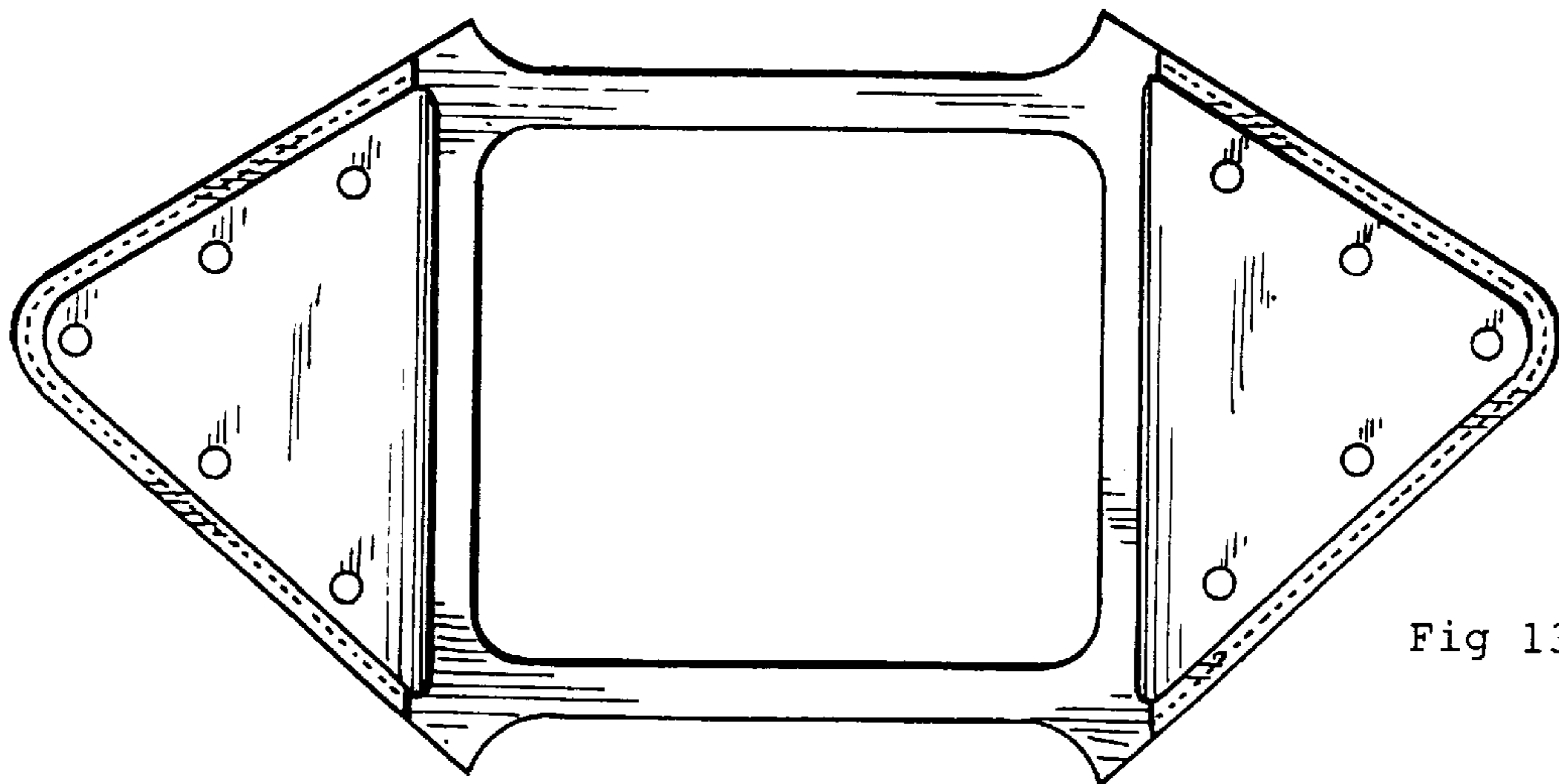

Fig 13