



US00D409961S

United States Patent [19]

Marsceau et al.

[11] Patent Number: Des. 409,961

[45] Date of Patent: ** May 18, 1999

[54] VEHICLE BUMPER

D. 400,146 10/1998 Marsceau D12/169

[76] Inventors: DeWayne Timothy Marsceau, 157
Haley Mill Rd., Easley, S.C. 29640;
Christopher James Sullivan, 120
Pennwood La., Greenville, S.C. 29609

Primary Examiner—Melody N. Brown
Attorney, Agent, or Firm—Ralph Bailey

[**] Term: 14 Years

[57] CLAIM

The ornamental design for a vehicle bumper, as shown and described.

[21] Appl. No.: 29/086,617

DESCRIPTION

[22] Filed: Apr. 16, 1998

[51] LOC (6) Cl. 12-16

[52] U.S. Cl. D12/169

[58] Field of Search D12/169; 293/102,
293/115, 120

FIG. 1 is a left front perspective view of a vehicle bumper illustrating our new design;
FIG. 2 is a front elevation further illustrating our new design, it being understood that the broken lines are for illustrative purposes, showing attachment on the back end of an automotive vehicle, and form no part of the claimed design;
FIG. 3 is an enlarged right side elevation view thereof;
FIG. 4 is a rear elevation view thereof;
FIG. 5 is a top plan view thereof;
FIG. 6 is a bottom plan view thereof; and,
FIG. 7 is an enlarged right rear perspective view of the left hand portion of the vehicle bumper.

[56] References Cited

U.S. PATENT DOCUMENTS

D. 352,019	11/1994	Rivero et al.	D12/169
D. 370,447	6/1996	Parker	D12/169
D. 375,066	10/1996	Tisi	D12/169
D. 377,469	1/1997	Howlett	D12/169
D. 395,416	1/1998	Shklyaver	D12/169

1 Claim, 3 Drawing Sheets

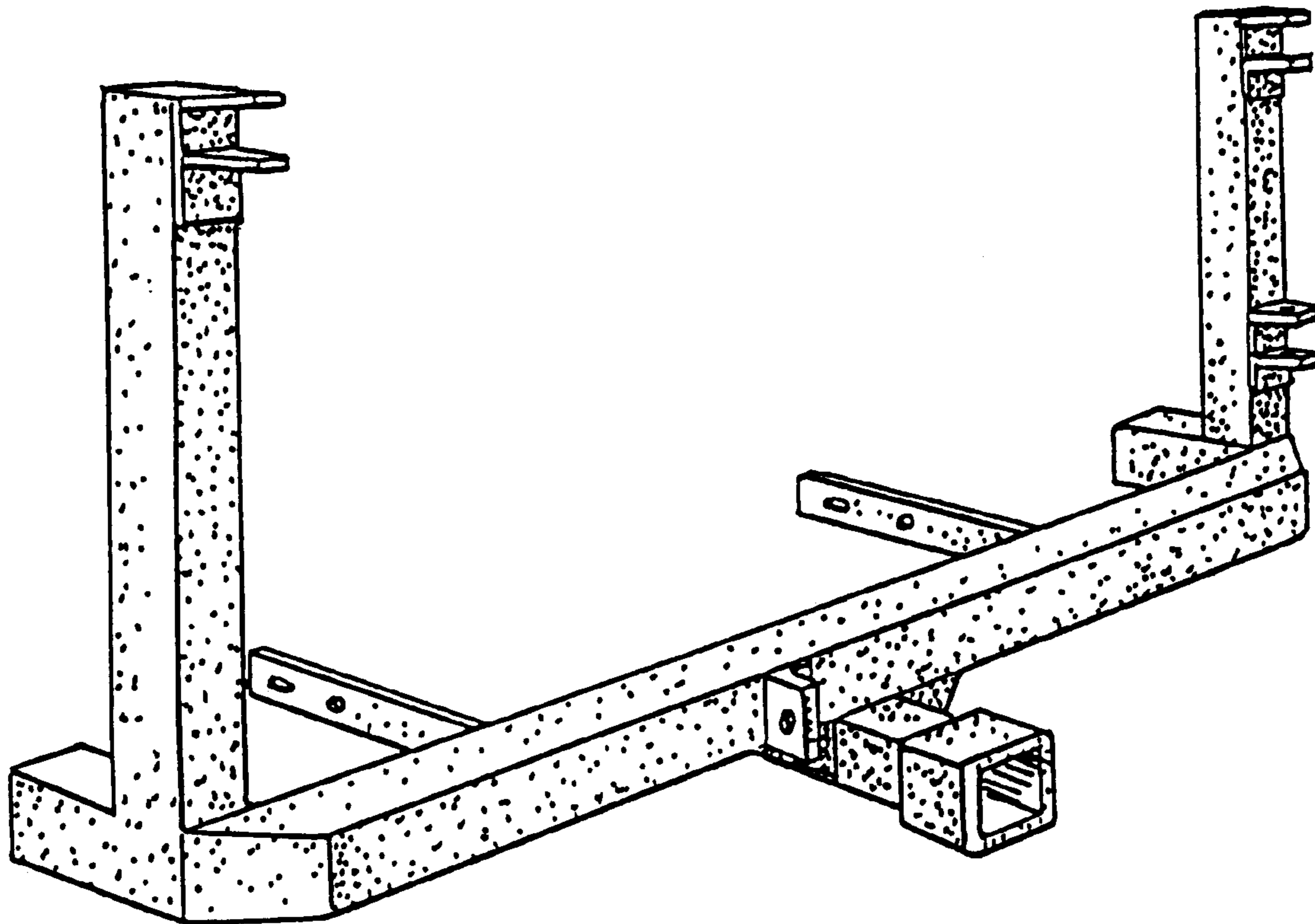

Fig. 1.

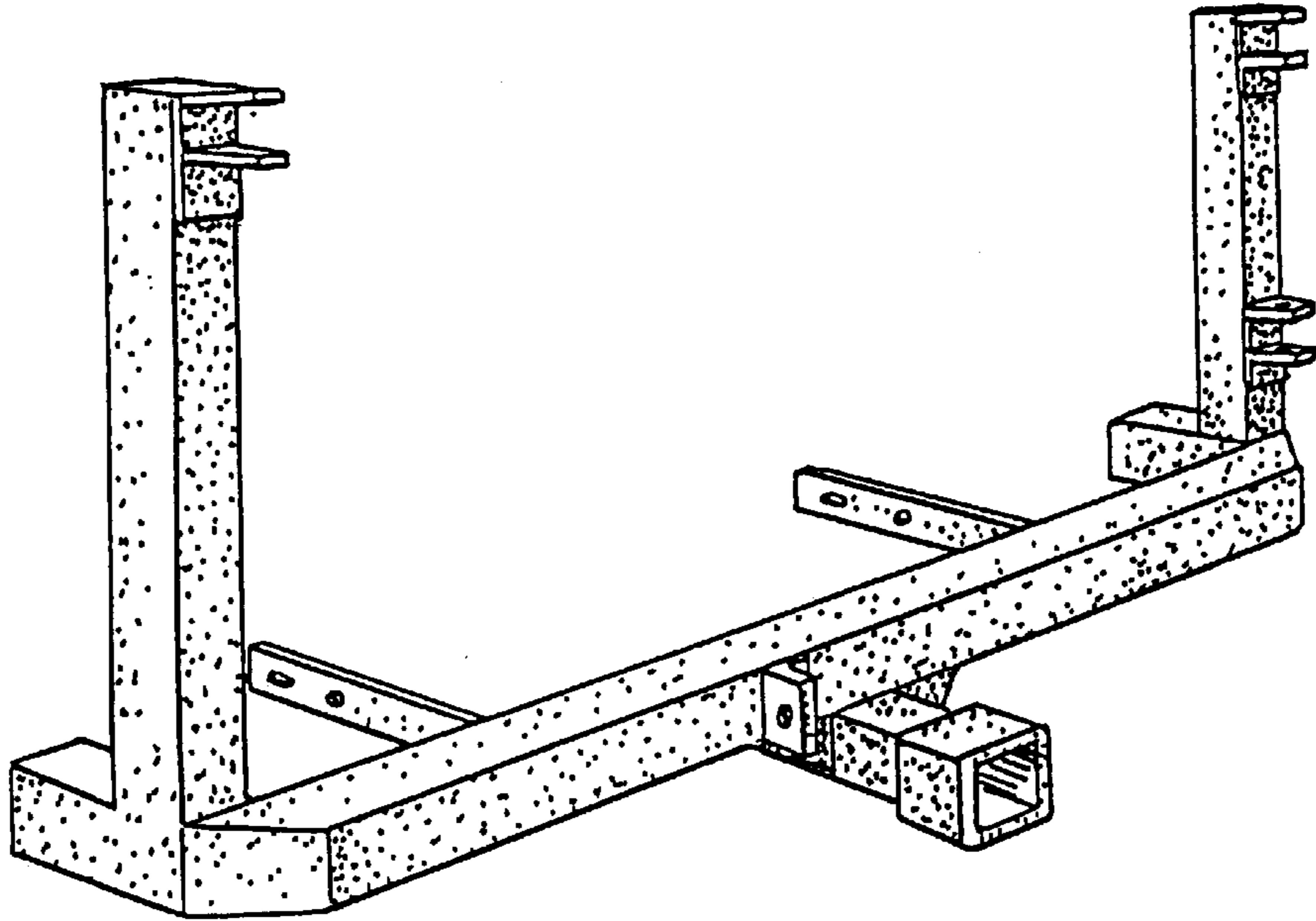

Fig. 2.

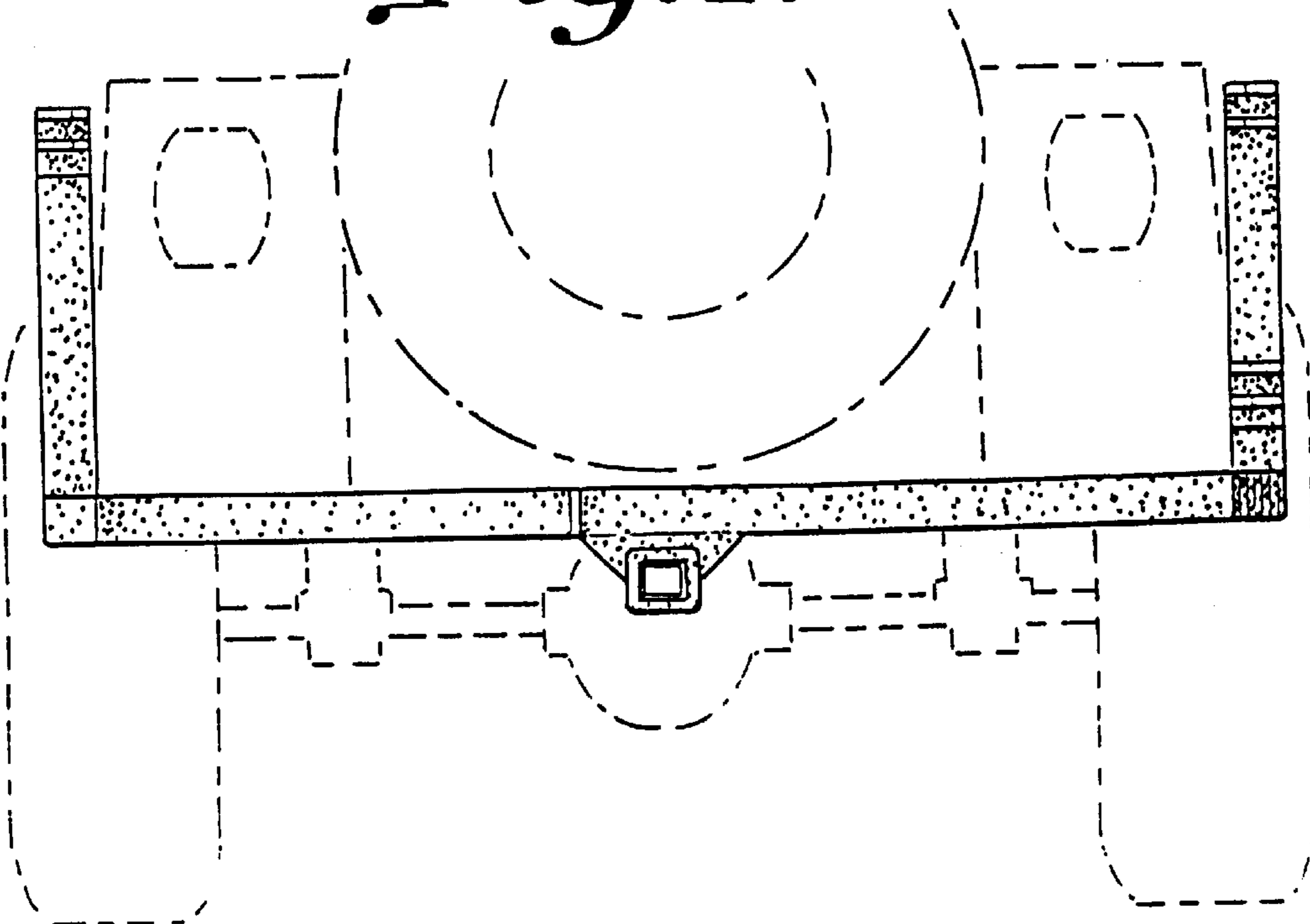

Fig. 3.

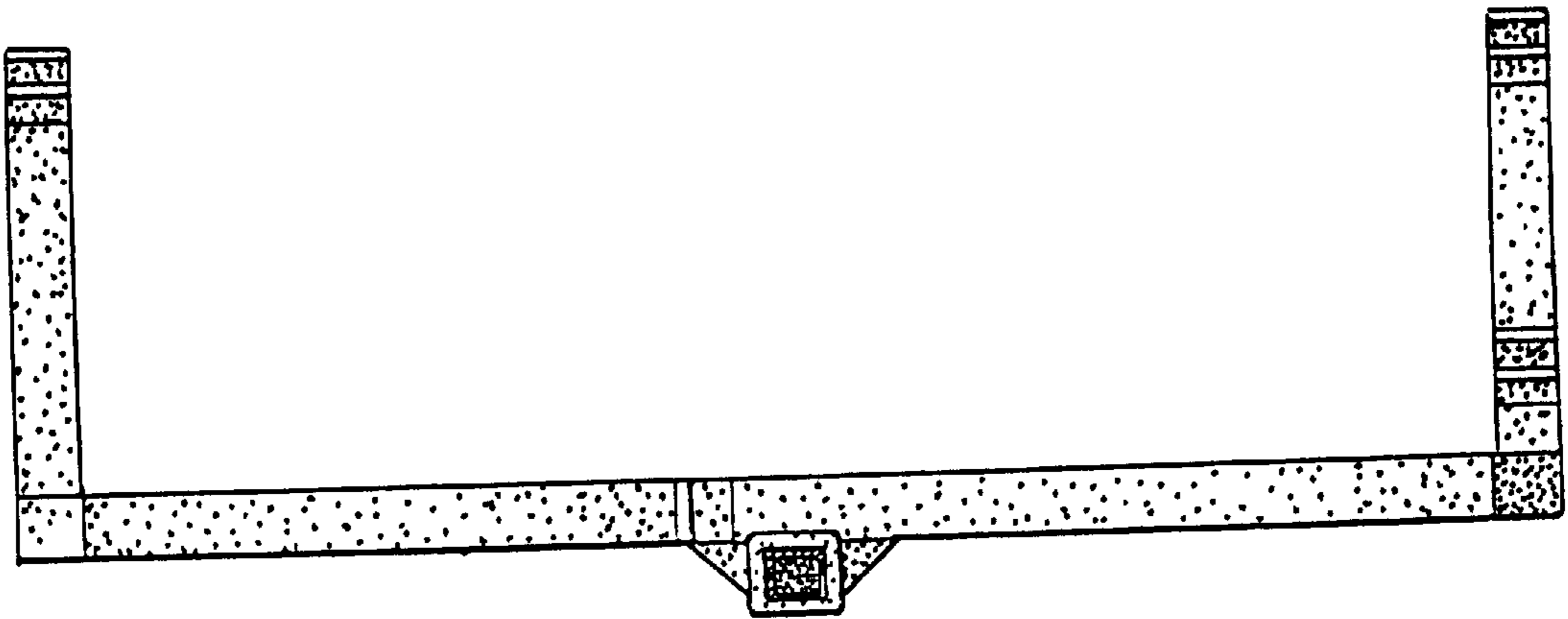
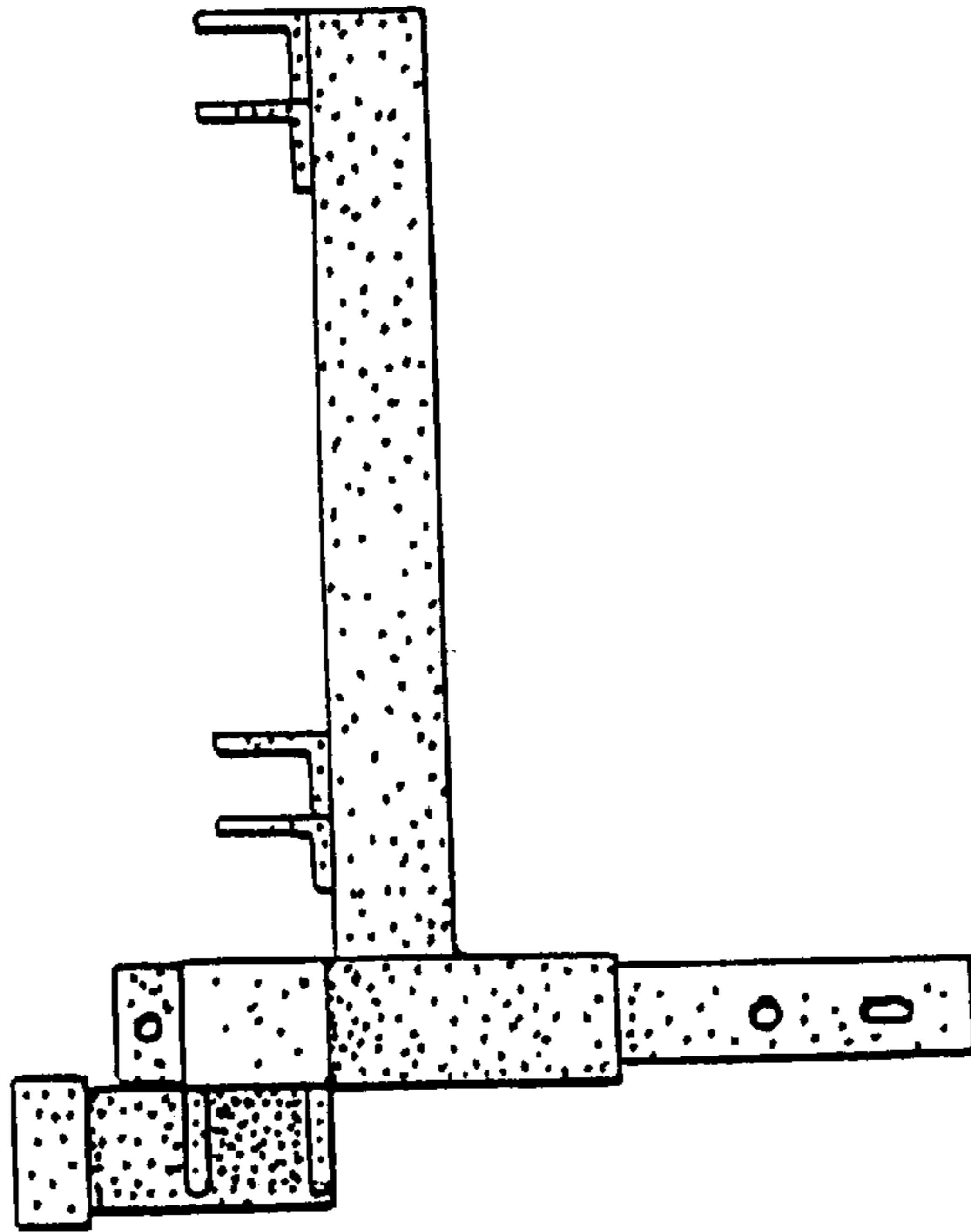

Fig. 4.

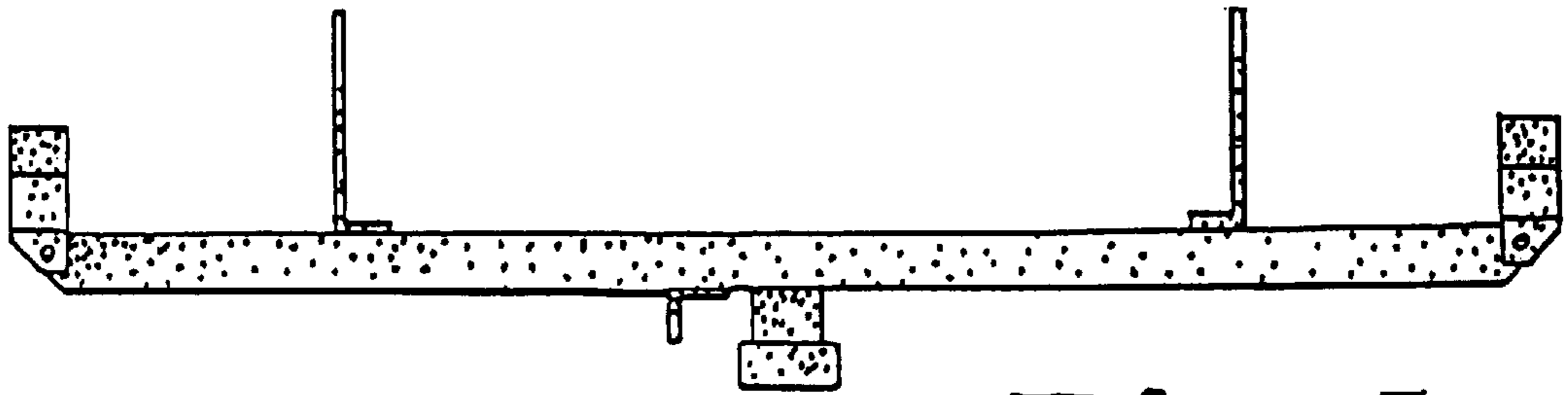

Fig. 5.

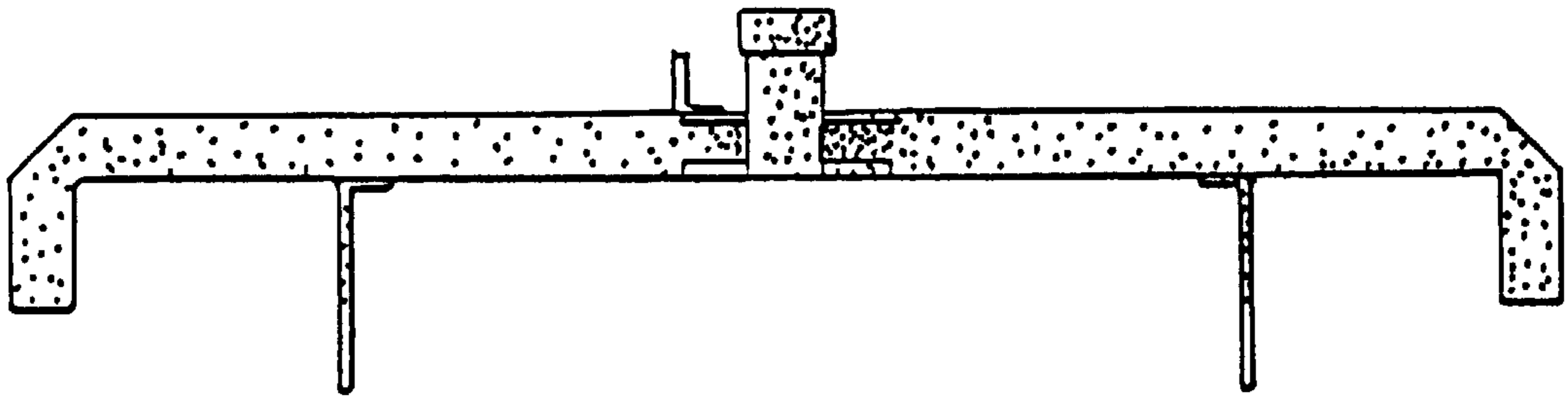

Fig. 6.

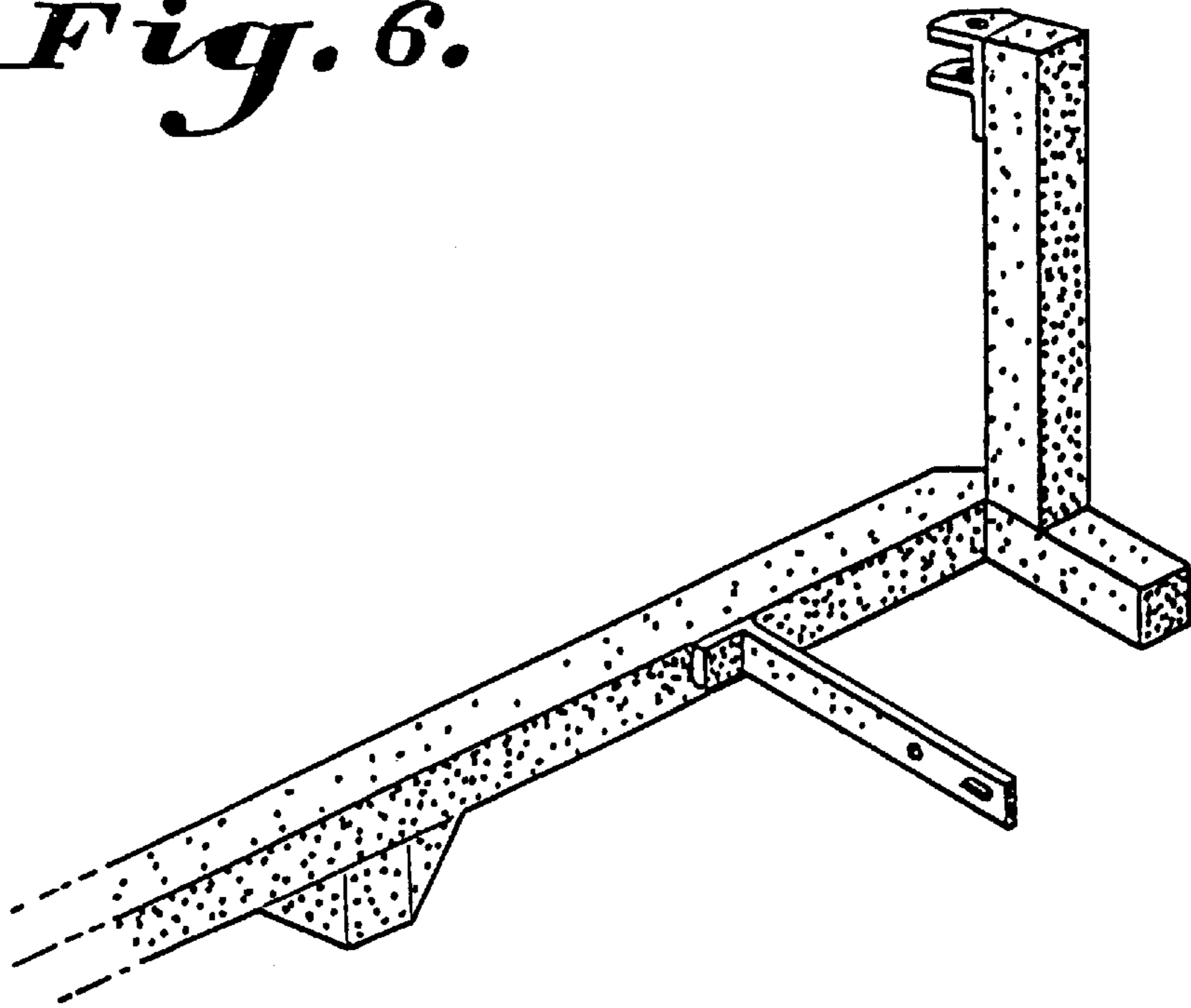

Fig. 7.