



US00D409927S

# United States Patent [19]

Wiegers et al.

[11] Patent Number: **Des. 409,927**

[45] Date of Patent: **\*\* May 18, 1999**

[54] **NAVIGATIONAL DEVICE**

[75] Inventors: **Michael R. Wiegers; Jeffrey D. Minelli**, both of Olathe, Kans.

[73] Assignee: **Garmin Corporation**, Taiwan

[\*\*] Term: **14 Years**

[21] Appl. No.: **29/081,427**

[22] Filed: **Jan. 2, 1998**

[51] **LOC (6) Cl.** ..... **10-04**

[52] **U.S. Cl.** ..... **D10/65**

[58] **Field of Search** ..... D10/65, 75, 78;  
D14/100, 104, 106, 107; 364/444, 499;  
342/419, 457, 357

[56] **References Cited**

**U.S. PATENT DOCUMENTS**

D. 216,984	3/1970	Stanford et al.	.....	D10/75
D. 291,288	8/1987	Suzuki	.....	D10/78
D. 301,882	6/1989	Watanabe	.....	D14/140
D. 302,271	7/1989	Watanabe	.....	D14/140
D. 314,713	2/1991	Ciranny et al.	.....	D10/65
D. 326,450	5/1992	Watanabe	.....	D14/138
D. 337,582	7/1993	Lewo	.....	D14/144
D. 365,032	12/1995	Laverick et al.	.....	D10/78
D. 365,292	12/1995	Laverick et al.	.....	D10/78

D. 390,484	2/1998	Nishimura et al.	.....	D10/75
4,050,798	9/1977	Boggs	.....	353/35
4,868,715	9/1989	Putman et al.	.....	361/422
4,969,647	11/1990	Mical et al.	.....	273/85
5,068,765	11/1991	Nimpoeno	.....	361/422
5,103,377	4/1992	Kobayashi et al.	.....	361/394
5,204,817	4/1993	Yoshida	.....	364/449
5,229,925	7/1993	Spencer et al.	.....	361/422
5,333,116	7/1994	Hawkins et al.	.....	364/708.1
5,408,385	4/1995	Fowler et al.	.....	361/784
5,434,789	7/1995	Fraker et al.	.....	364/460

*Primary Examiner*—Antoine Duval Davis  
*Attorney, Agent, or Firm*—Shook, Hardy & Bacon LLP

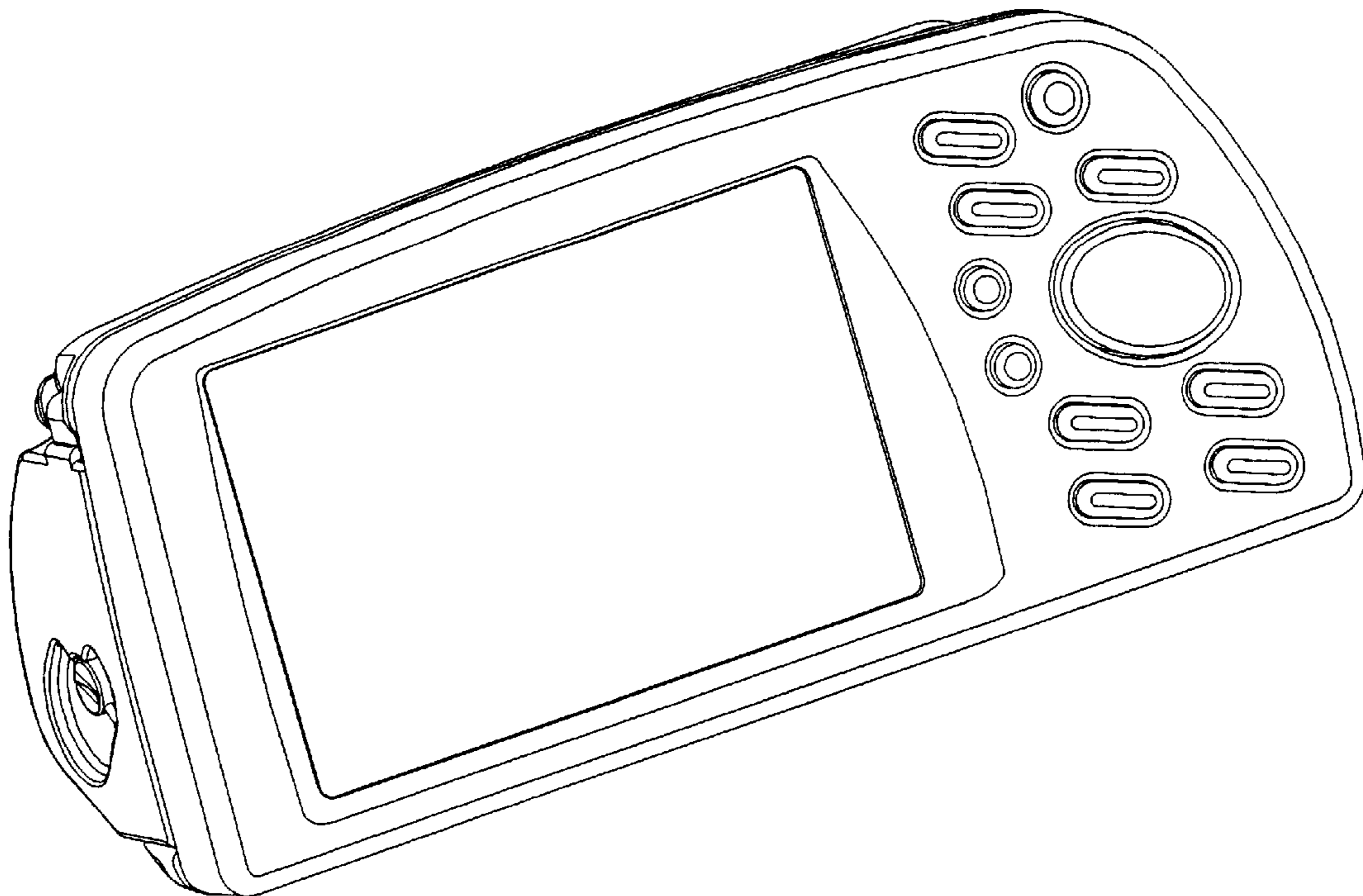
[57] **CLAIM**

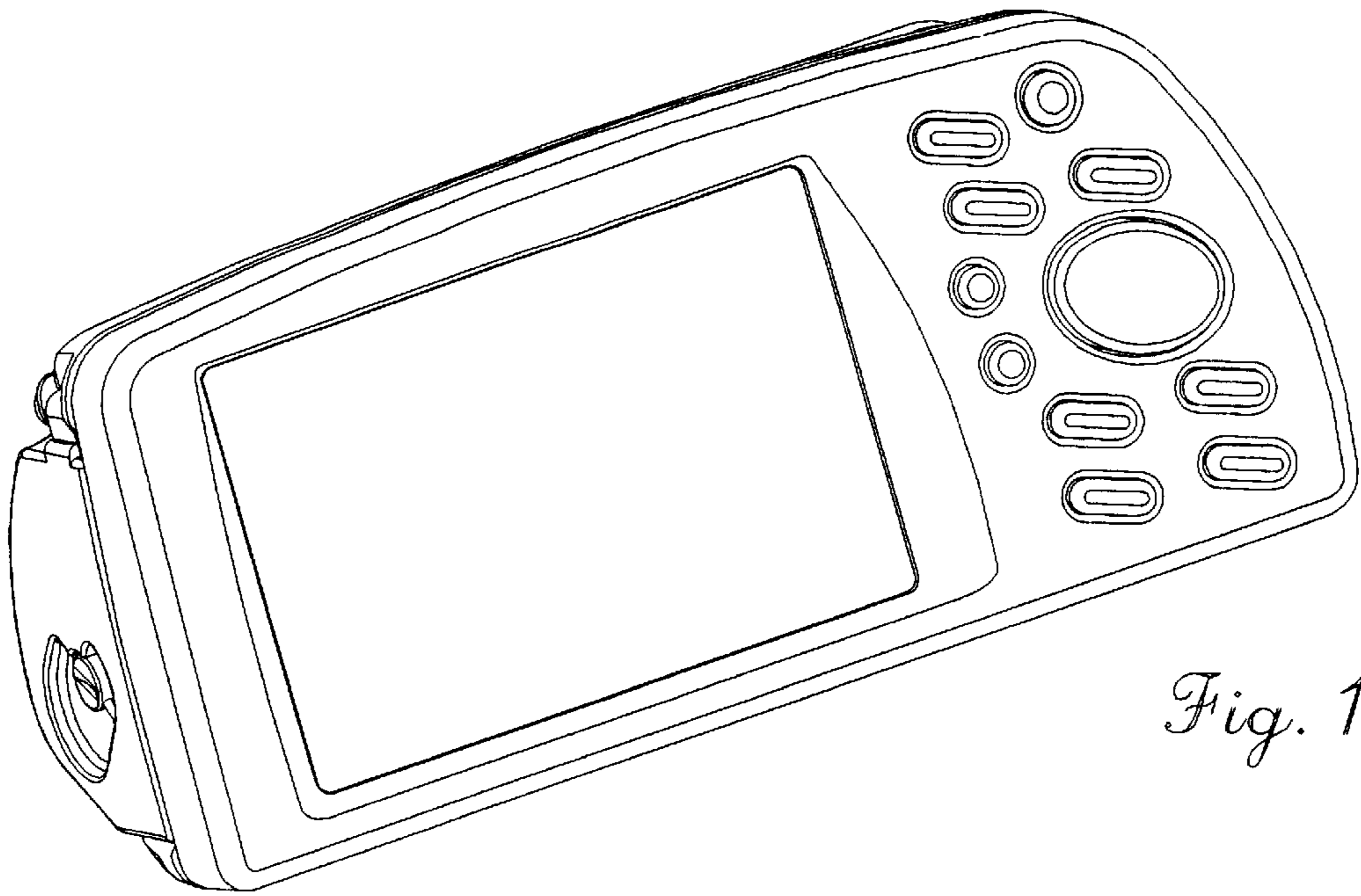
The ornamental design for a navigational device, as shown and described.

**DESCRIPTION**

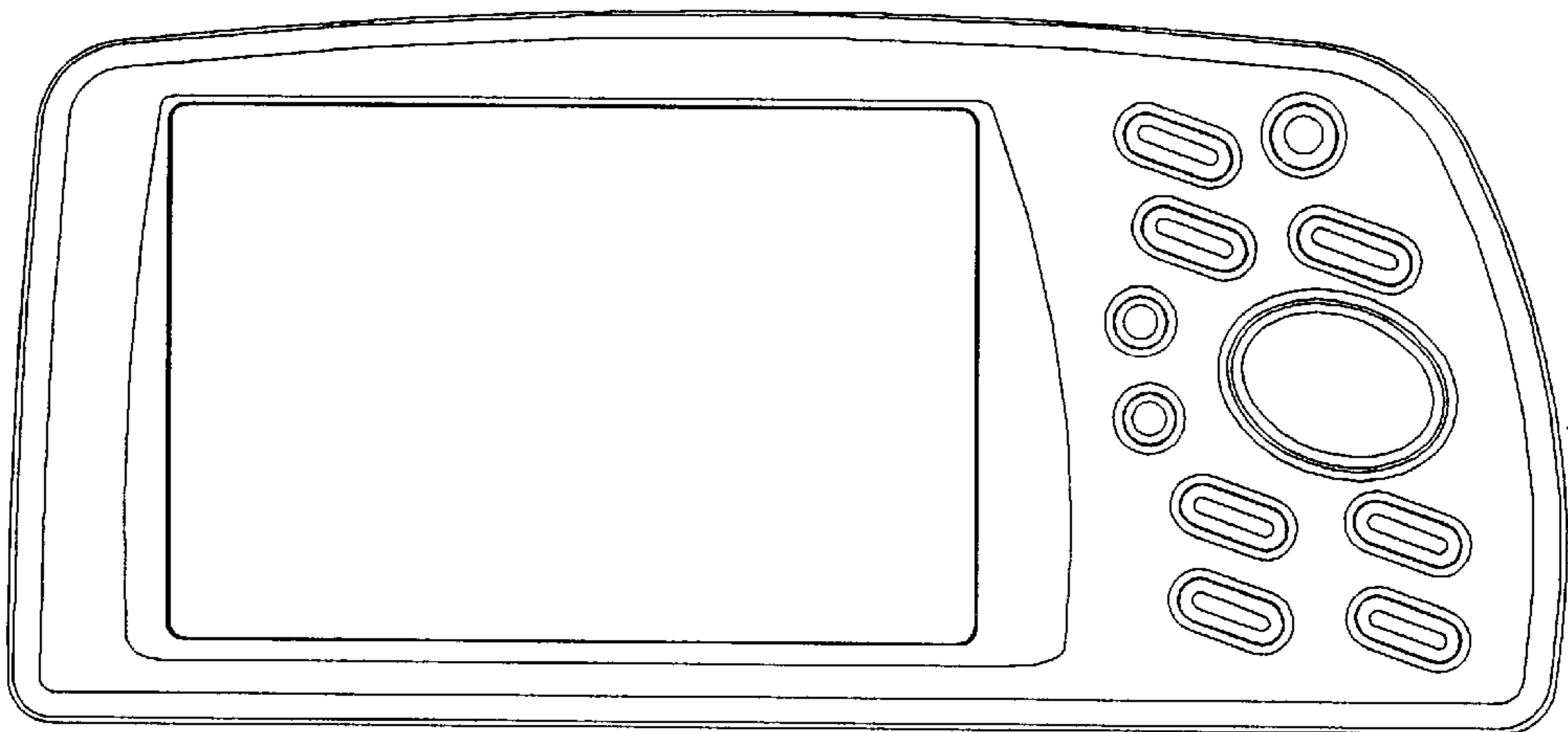
FIG. 1 is a perspective view of a navigational device according to the present invention;  
FIG. 2 is a front elevational view thereof;  
FIG. 3 is a top plan view thereof;  
FIG. 4 is a left end view thereof;  
FIG. 5 is a right end view thereof;  
FIG. 6 is a bottom plan view thereof; and,  
FIG. 7 is a rear elevational view thereof.

**1 Claim, 2 Drawing Sheets**

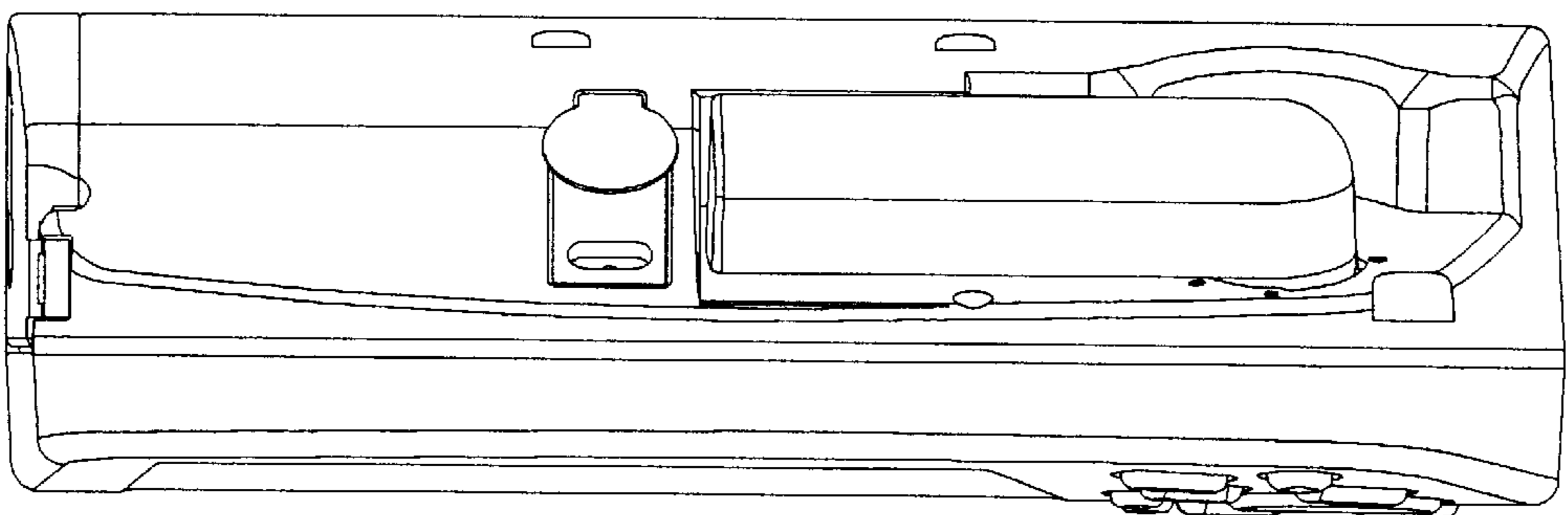




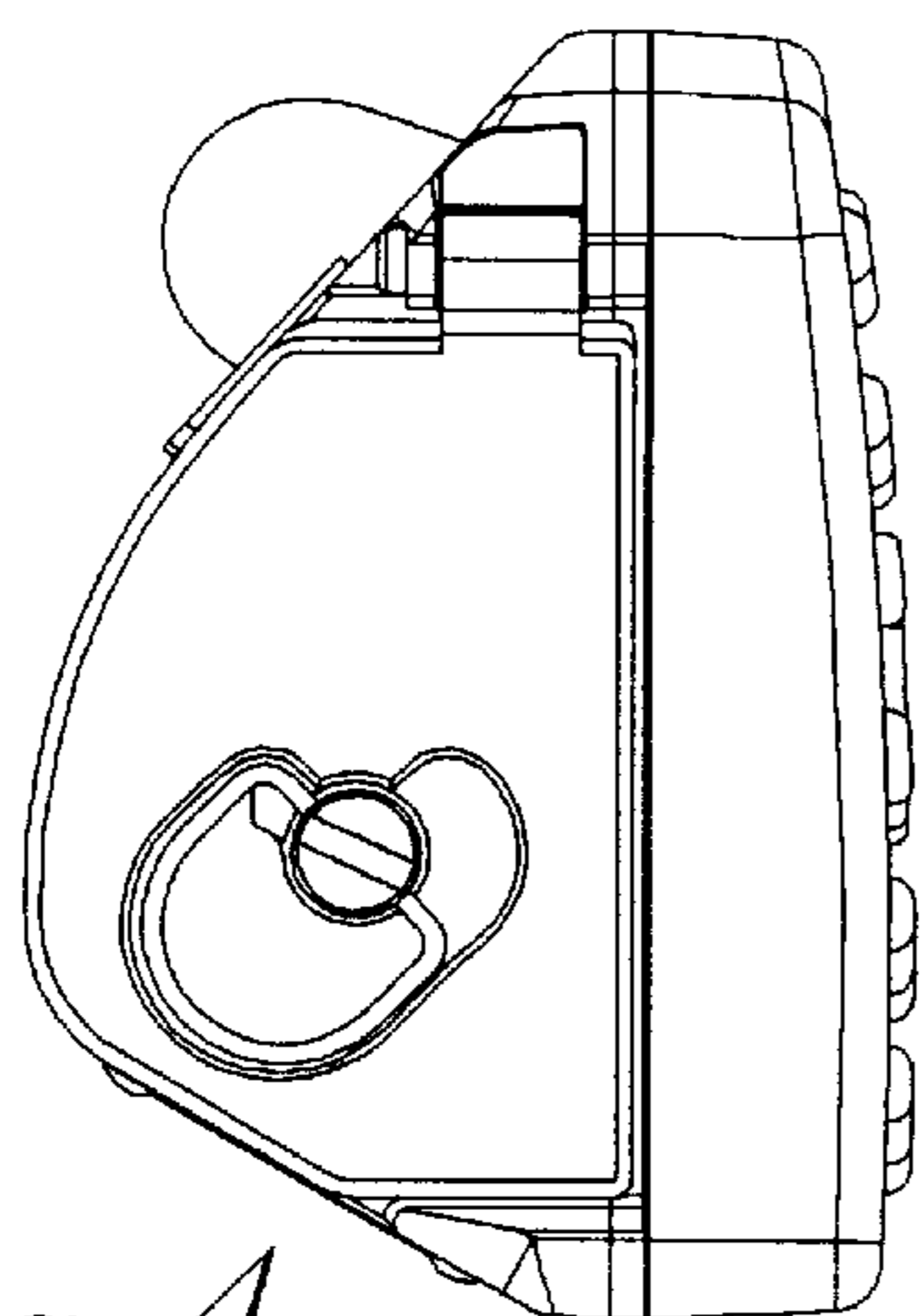
*Fig. 1.*



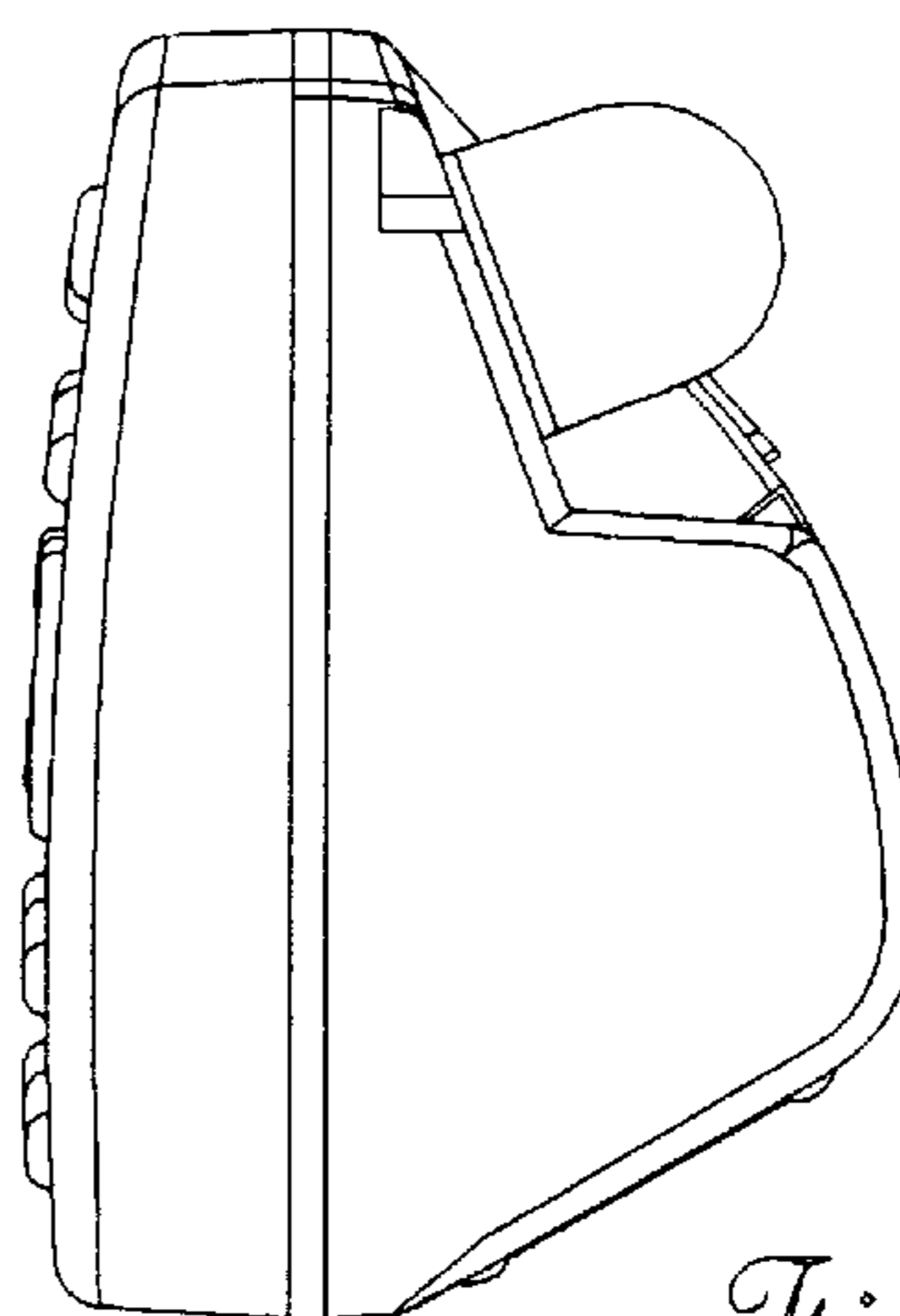
*Fig. 2.*



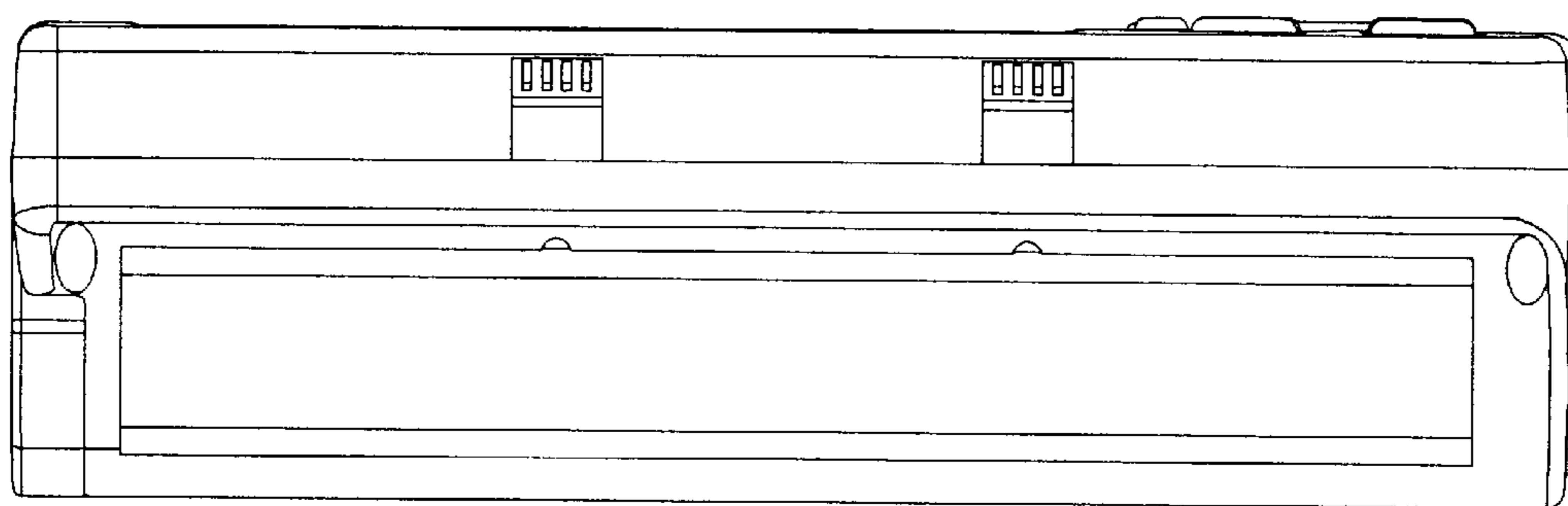
*Fig. 3.*



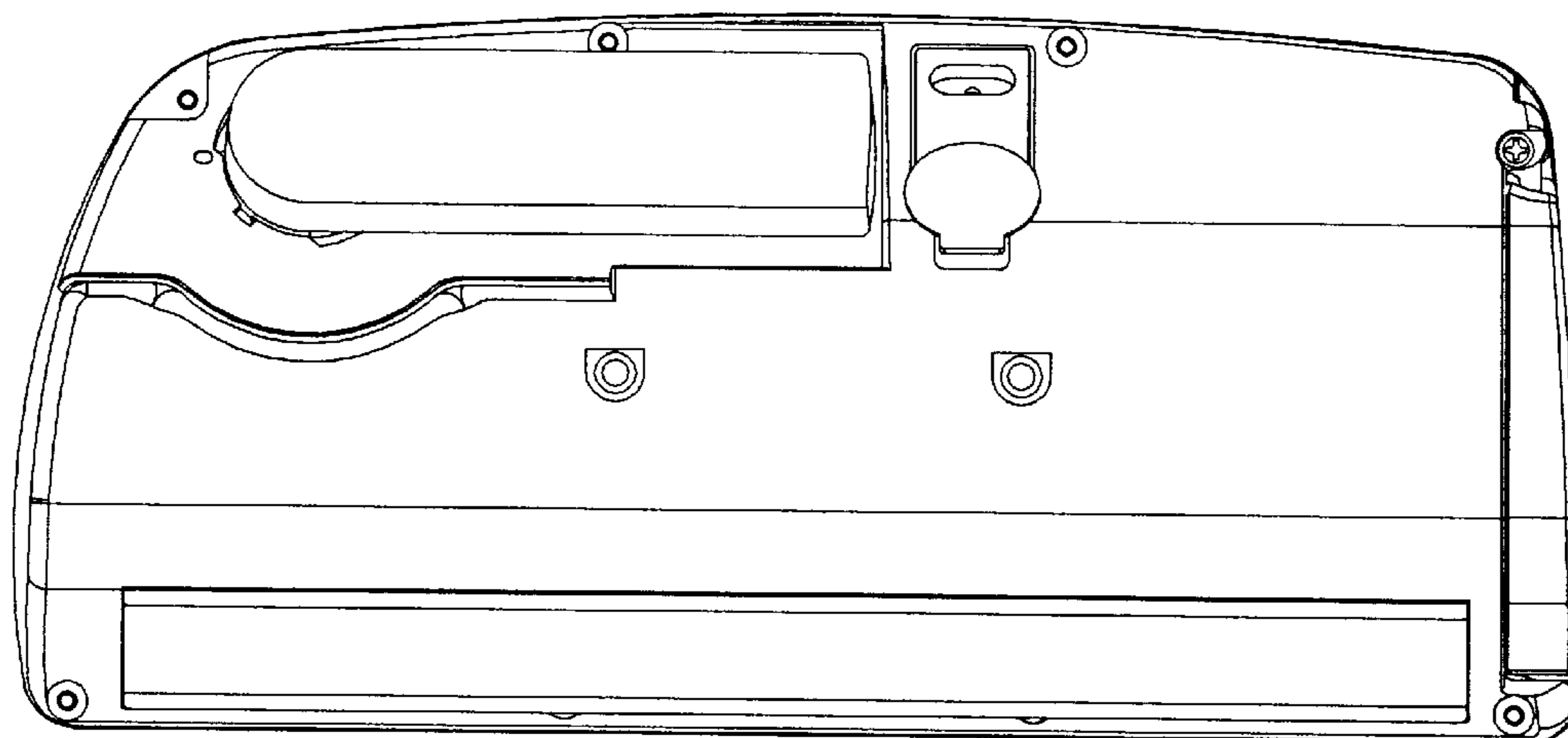
*Fig. 4.*



*Fig. 5.*



*Fig. 6.*



*Fig. 7.*