



US00D409859S

# United States Patent [19]

[11] **Patent Number: Des. 409,859**

**Papadakis et al.**

[45] **Date of Patent: \*\* May 18, 1999**

[54] **COUNTERTOP SALES STAND**

[75] Inventors: **Chris Papadakis**, Jamaica Estates; **Eric Nelsen**, Glen Cove; **Michael Keshner**, Merrick, all of N.Y.

[73] Assignee: **Philip Morris Incorporated**, New York, N.Y.

[\*\*] Term: **14 Years**

[21] Appl. No.: **29/078,925**

[22] Filed: **Nov. 5, 1997**

[51] **LOC (6) Cl. .... 06-04**

[52] **U.S. Cl. .... D6/472**

[58] **Field of Search** ..... D6/470-472, 396; 312/116, 118, 114, 126-129; D20/19; D7/601, 610, 612; 220/200, 602; 206/769-774

[56] **References Cited**

**U.S. PATENT DOCUMENTS**

- D. 60,083 12/1921 Burns .
- D. 76,297 9/1928 Geyer .
- D. 97,725 12/1935 Botham .
- D. 154,677 8/1949 Hawkins .
- D. 176,432 12/1955 Smith .
- D. 202,058 8/1965 D'Amato .
- D. 204,044 3/1966 Bayly .
- D. 226,748 4/1973 Miller ..... D6/470
- D. 250,789 1/1979 Mergenthaler .
- D. 254,821 4/1980 Rabas .
- D. 300,995 5/1989 Fruscio ..... D6/475
- D. 302,910 8/1989 Cocagne ..... D6/470
- D. 328,958 8/1992 Bragin et al. .
- D. 334,303 3/1993 Costello et al. .... D6/436
- D. 351,518 10/1994 Burgess ..... D6/470
- D. 351,956 11/1994 Kozak ..... D6/470

- D. 362,766 10/1995 Elhage ..... D6/470
- D. 370,800 6/1996 Bustos ..... D6/470
- D. 373,693 9/1996 Elhage ..... D6/470
- 2,635,029 4/1953 Fokakis .
- 3,357,597 12/1967 Groff .
- 3,858,757 1/1975 Langdon, Jr. .
- 4,494,658 1/1985 Simon et al. .
- 4,537,316 8/1985 Simon .
- 4,742,936 5/1988 Rein .
- 4,796,763 1/1989 Franklin et al. .
- 5,040,674 8/1991 Bragin et al. .

**OTHER PUBLICATIONS**

Retail Reporting Corporation, Point of Purchase Design Annual 3, Kool 72 Pack Security Display, p. 202, 1995.

*Primary Examiner*—James Gandy  
*Assistant Examiner*—Linda Brooks  
*Attorney, Agent, or Firm*—Burns, Doane, Swecker & Mathis, L.L.P.

[57] **CLAIM**

The ornamental design for a countertop sales stand, as shown and described.

**DESCRIPTION**

FIG. 1 is a perspective view of a countertop sales stand showing our new design; FIG. 2 is a side elevational view thereof; FIG. 3 is a side elevational view of the other side thereof; FIG. 4 is a front elevational view thereof; FIG. 5 is a rear elevational view thereof; and, FIG. 6 is a top plan view thereof. The broken line showing of display shelves and packaged products in FIGS. 1-5 is for illustrative purposes only and forms no part of the claimed design.

**1 Claim, 5 Drawing Sheets**

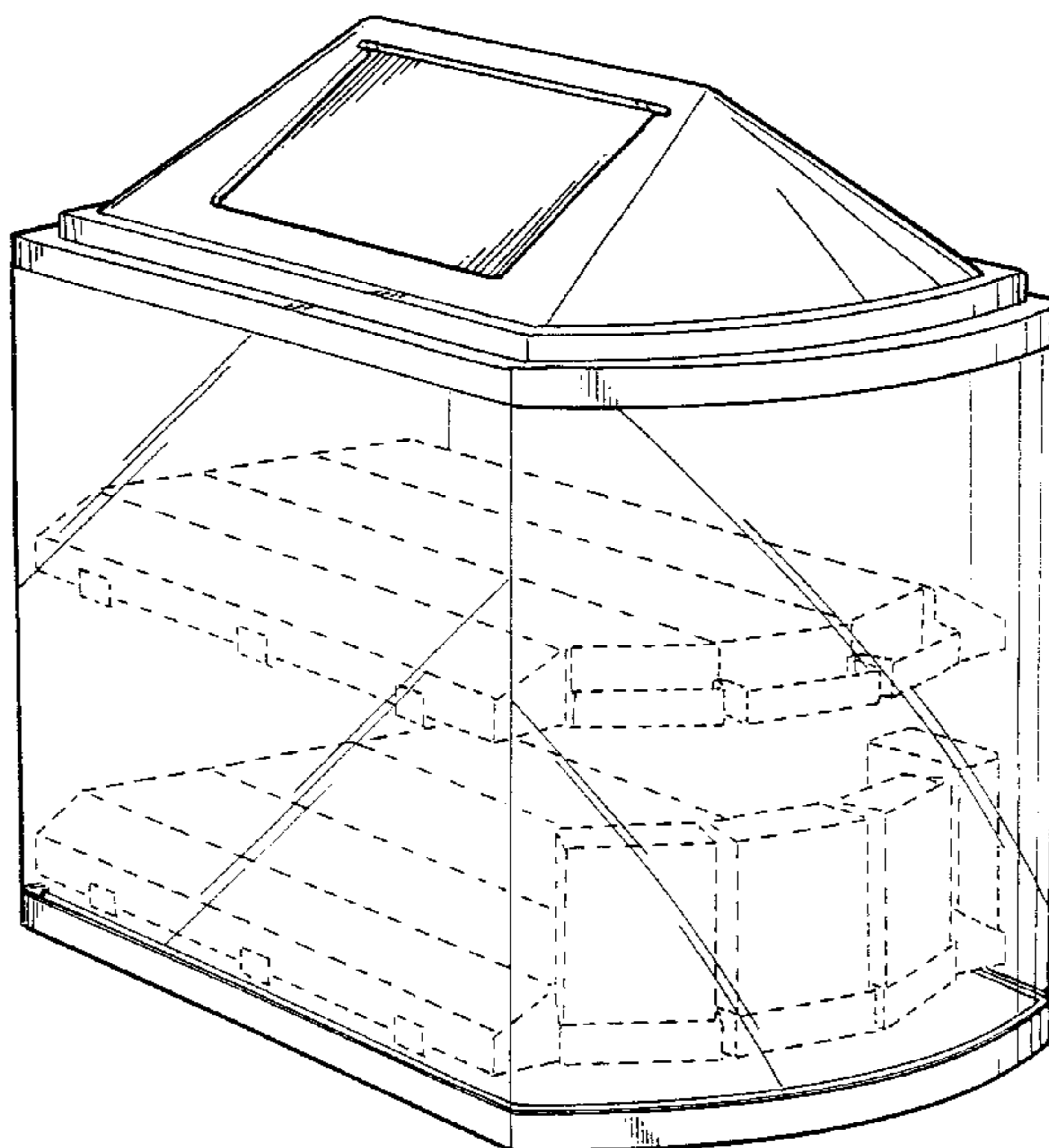

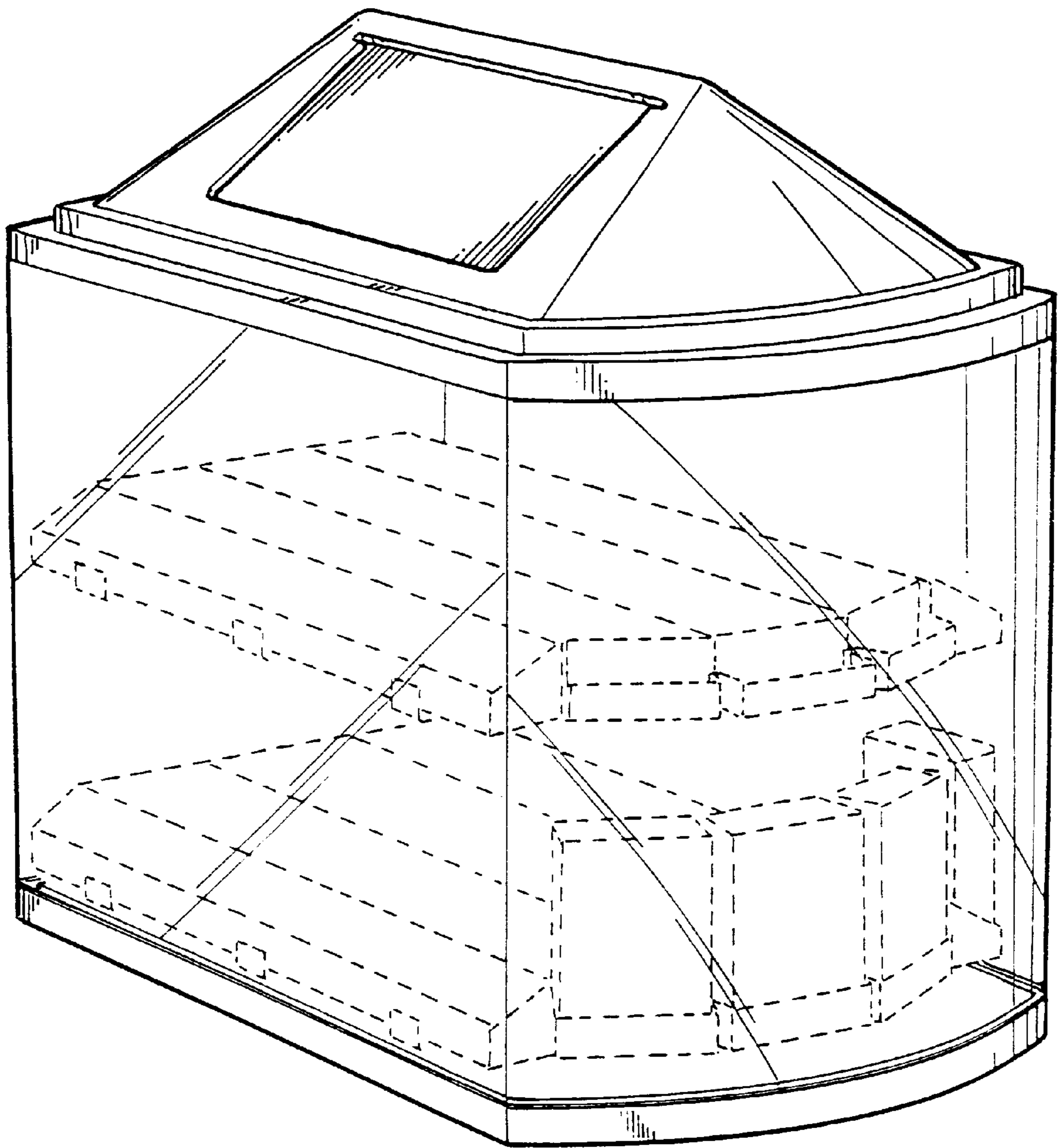

FIG. 1

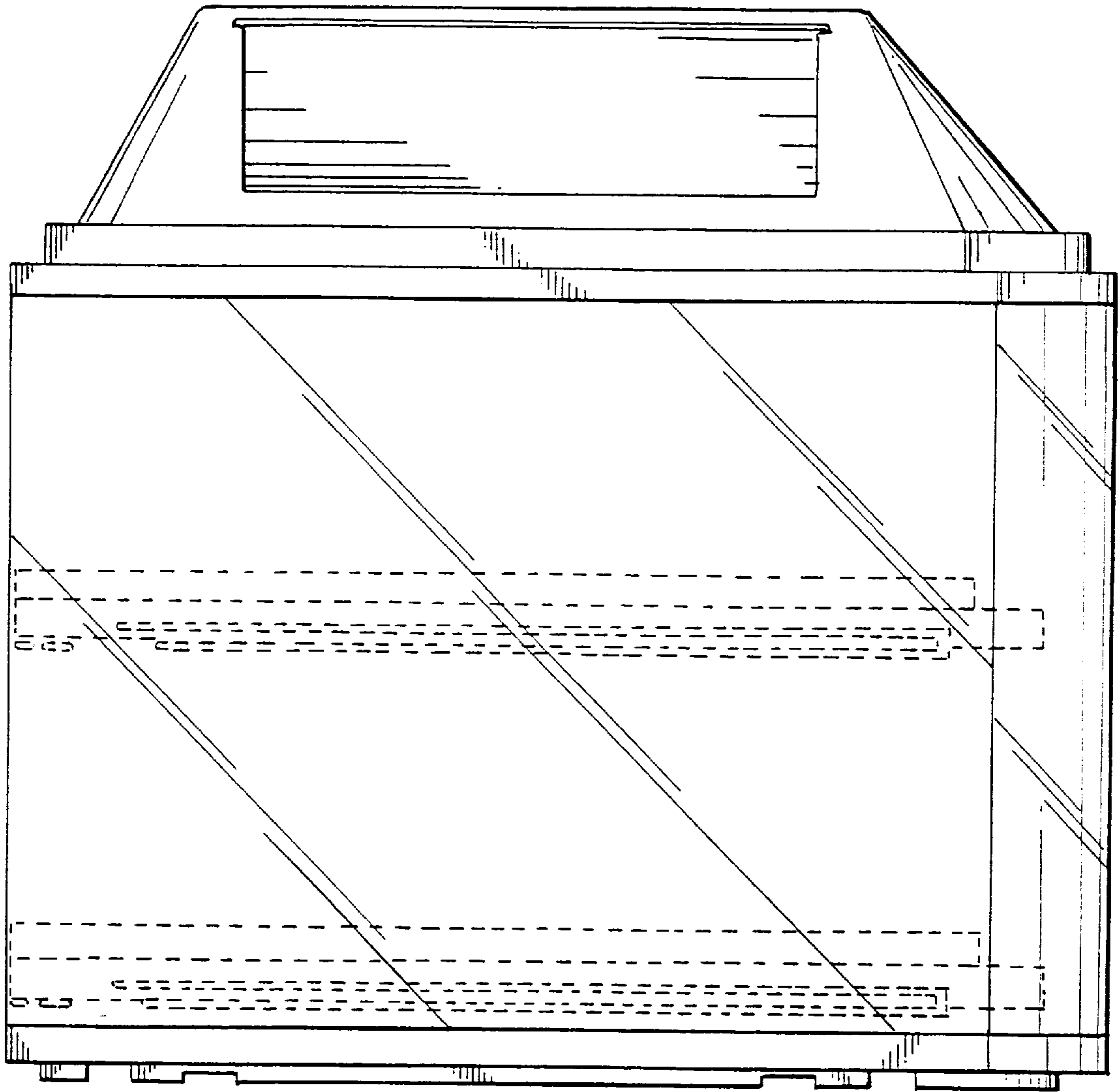

FIG. 2

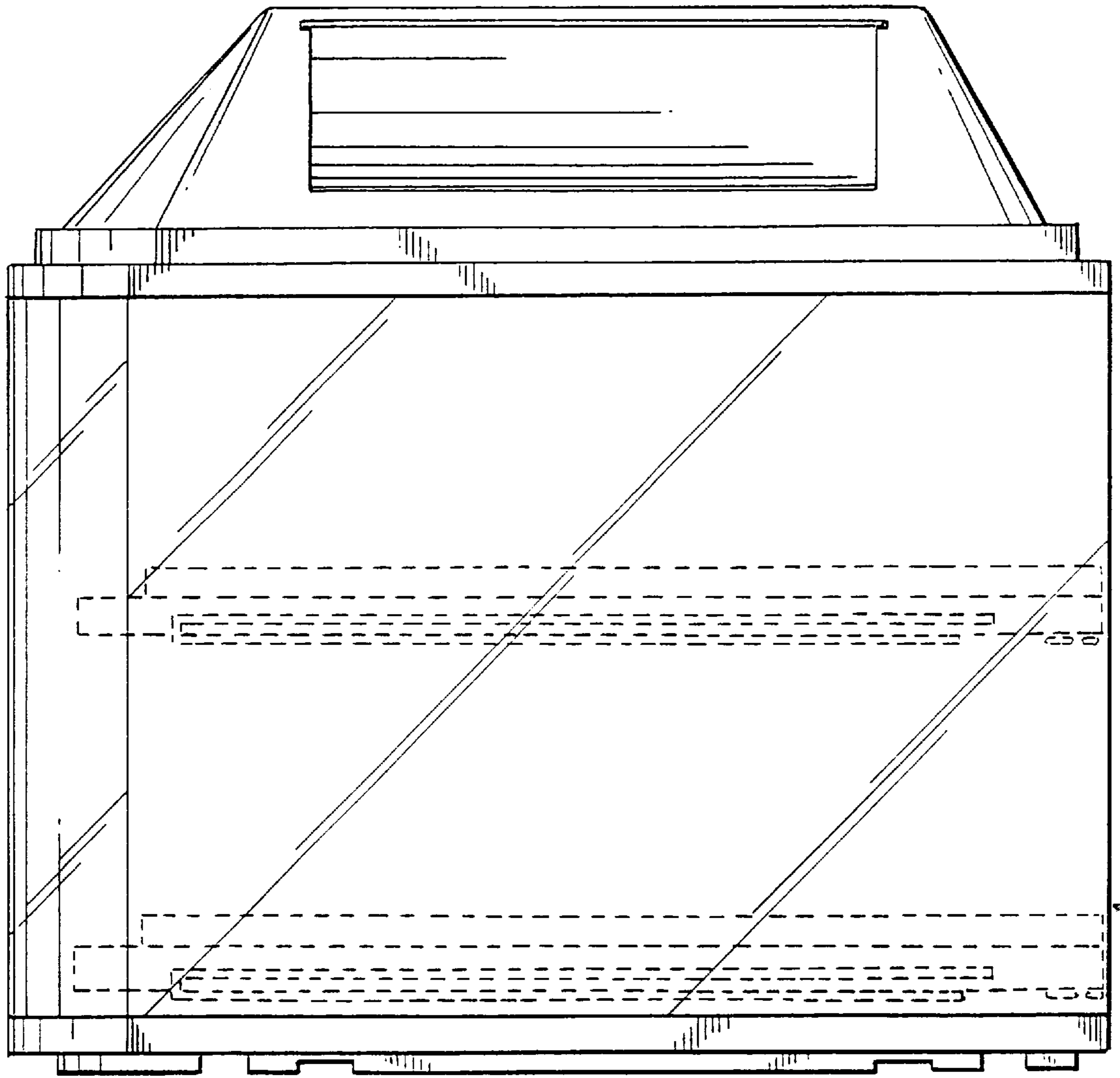

FIG. 3

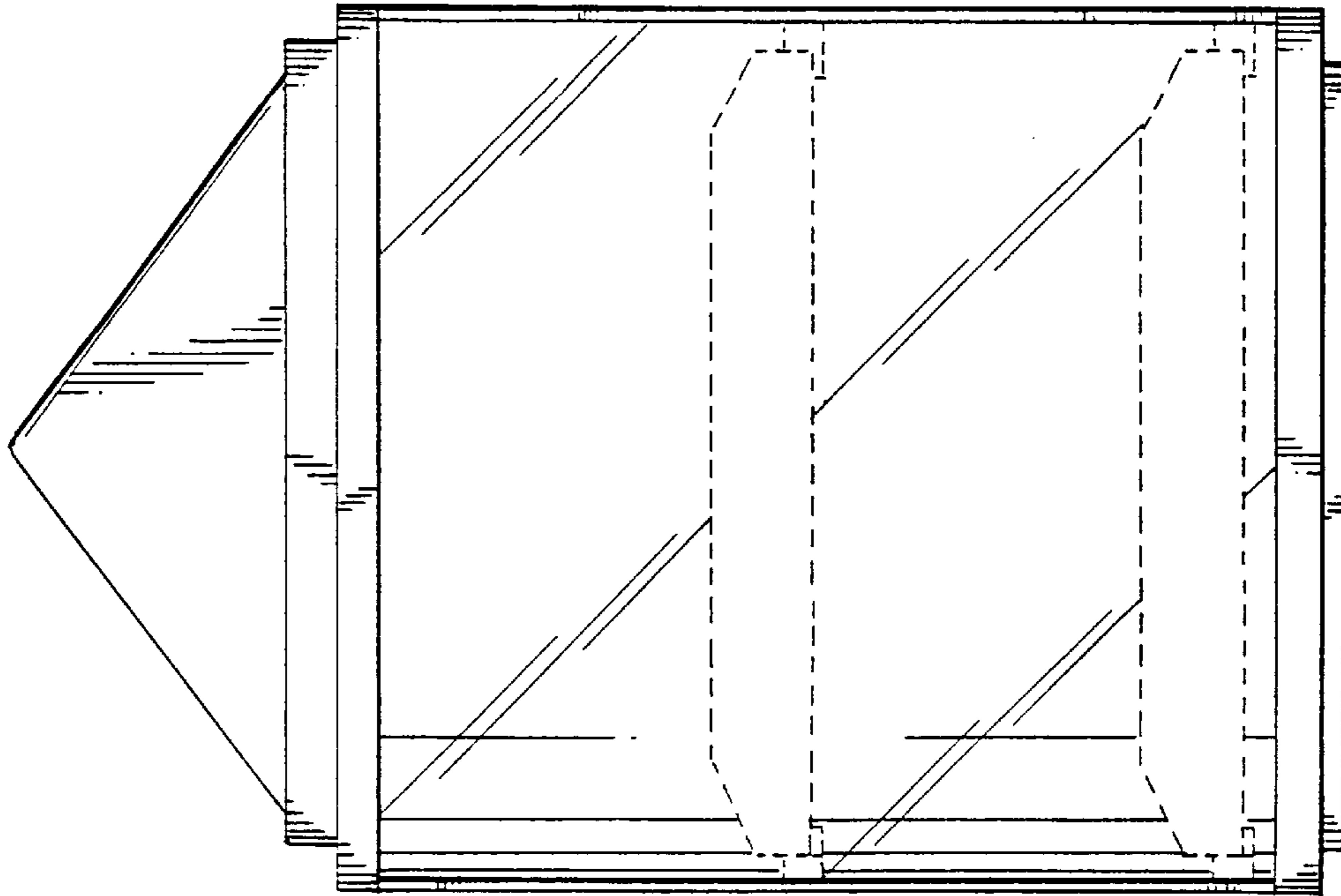

FIG. 5

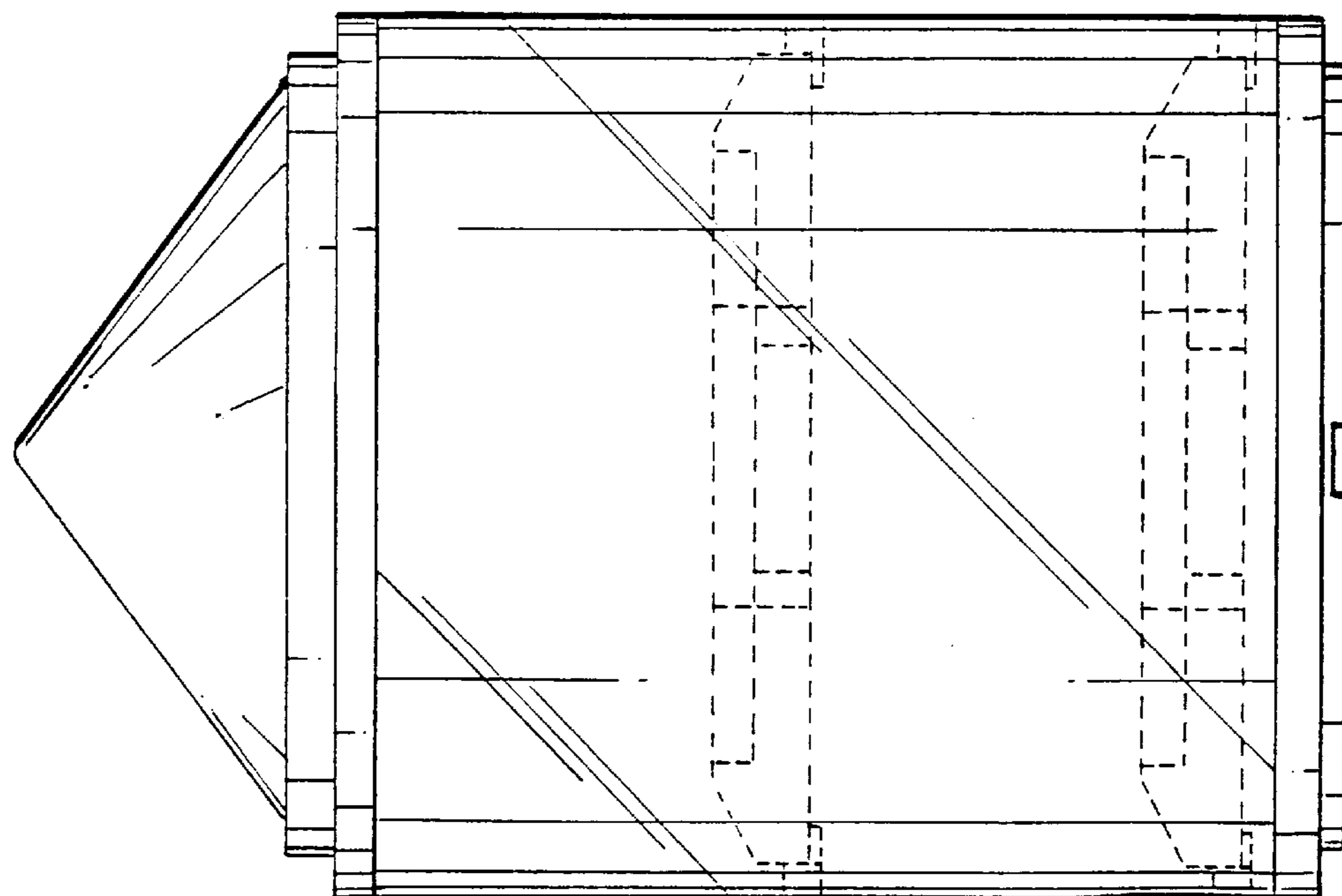

FIG. 4

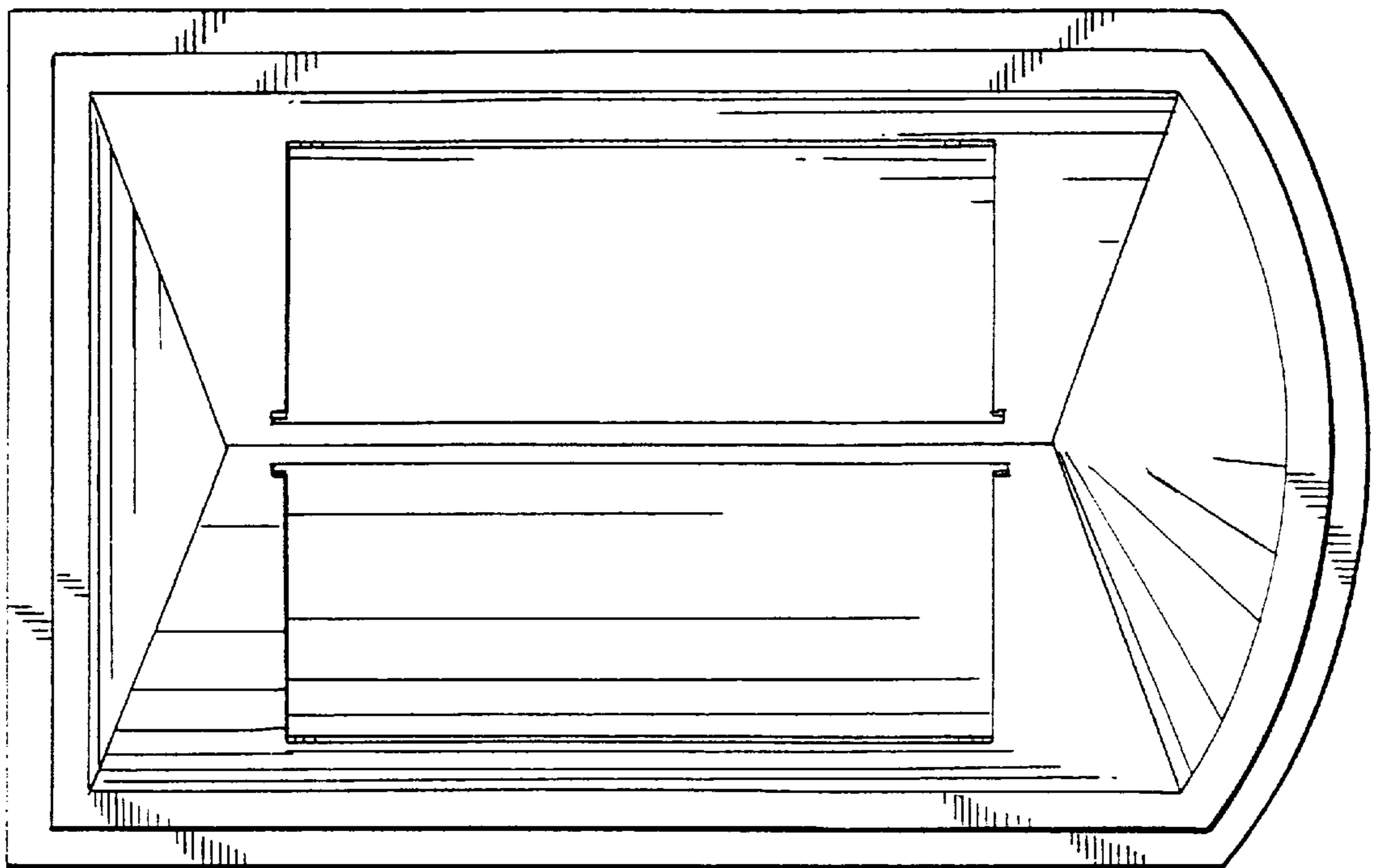

FIG. 6