



US00D409761S

United States Patent [19] O'Reilly

[11] Patent Number: Des. 409,761

[45] Date of Patent: ** May 11, 1999

[54] **COMBINED TELEPHONE BOOTH AND ADVERTISING DISPLAY UNIT**

[76] Inventor: **Lawrence Patrick O'Reilly**, 832 N. Town & River Dr., Ft Myers, Fla. 33919

[**] Term: **14 Years**

[21] Appl. No.: **29/091,221**

[22] Filed: **Jul. 24, 1998**

[51] **LOC (6) Cl.** **25-03**

[52] **U.S. Cl.** **D25/16**

[58] **Field of Search** D25/16, 1; 52/36.1, 52/27, 27.5; D6/421, 396, 397, 455, 449; D14/146; 379/143, 146, 155, 419, 428, 440, 453; D20/19, 41; 40/584, 553, 568, 336, 611

D. 399,973	10/1998	O'Reilly .	
3,338,002	8/1967	Ericsson et al.	52/27.5
4,706,399	11/1987	Martin .	
4,754,582	7/1988	Cameron .	
4,797,914	1/1989	Vaello .	
4,845,869	7/1989	Martin .	
4,918,878	4/1990	Paschke et al. .	
4,961,294	10/1990	Cameron .	
4,998,388	3/1991	Englehart .	
5,029,339	7/1991	Caron .	
5,031,366	7/1991	Cameron .	
5,072,535	12/1991	Jenkins .	
5,216,853	6/1993	Dignan et al. .	
5,671,579	9/1997	Miranda Camino et al.	52/36.1

Primary Examiner—Doris Clark
Attorney, Agent, or Firm—Laura G. Barrow

[57] **CLAIM**

The ornamental design of a combined telephone booth and advertising display unit, as shown.

DESCRIPTION

FIG. 1 is a perspective view of a combined telephone booth and advertising display unit showing my new design. FIG. 2 is a front elevation view thereof. FIG. 3 is a right side elevation view thereof. FIG. 4 is a bottom plan view thereof. FIG. 5 is a top plan view thereof. FIG. 6 is a left side elevation view thereof. FIG. 7 is transverse cross-section of the combined telephone booth and advertising display unit taken along lines 7—7 of FIG. 1; and, FIG. 8 is a rear view thereof.

1 Claim, 7 Drawing Sheets

[56] **References Cited**

U.S. PATENT DOCUMENTS

D. 260,581	9/1981	Kostoff .	
D. 263,101	2/1982	George et al. .	
D. 263,102	2/1982	George et al. .	
D. 263,264	3/1982	George et al. .	
D. 300,093	3/1989	Ranz et al. .	
D. 305,689	1/1990	Lerch .	
D. 319,550	9/1991	Nichols et al. .	
D. 324,574	3/1992	Holland .	
D. 338,042	8/1993	Giammanco .	
D. 387,578	12/1997	Caya .	
D. 389,246	1/1998	Quinn	D25/16
D. 398,167	9/1998	O'Reilly .	

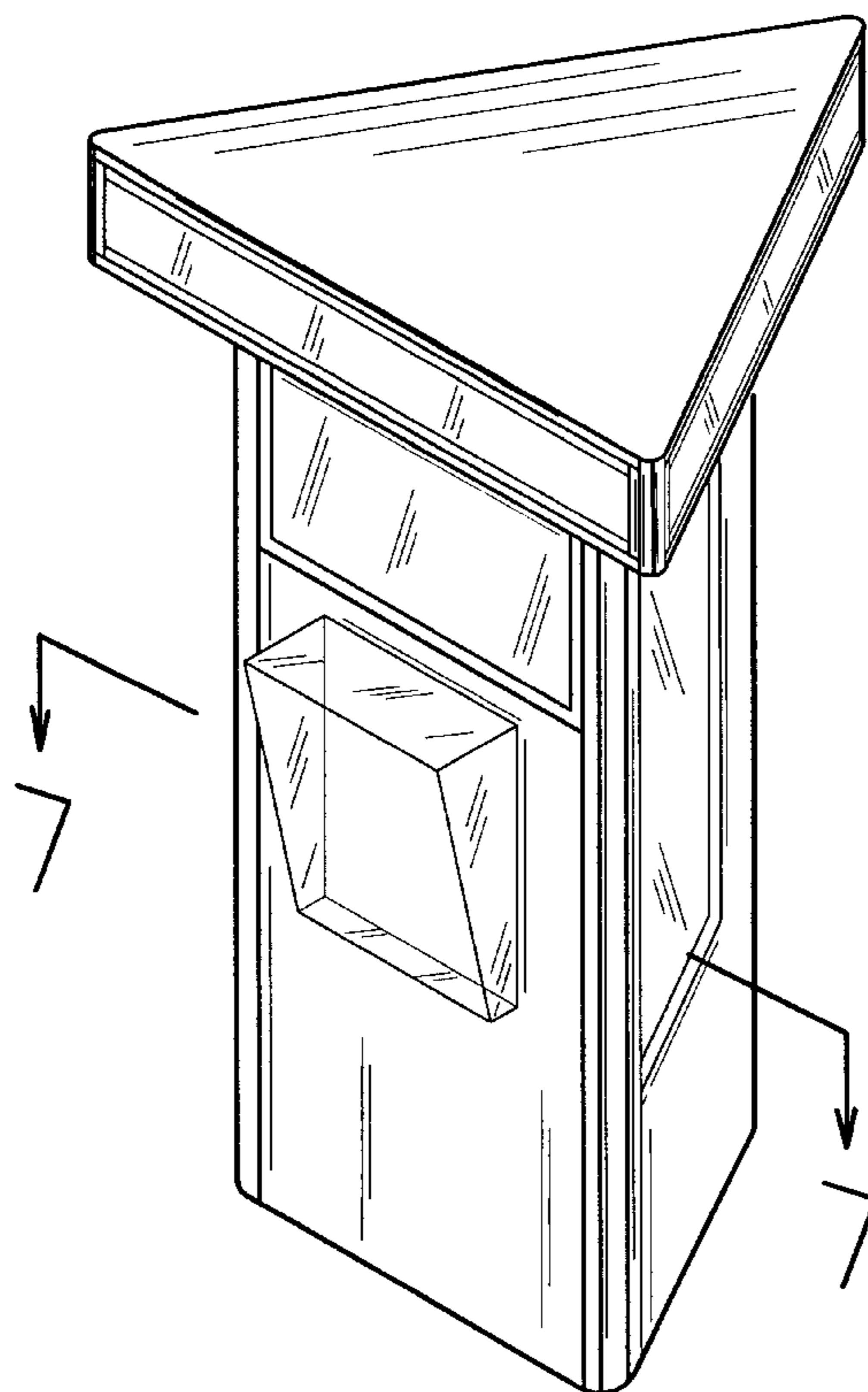

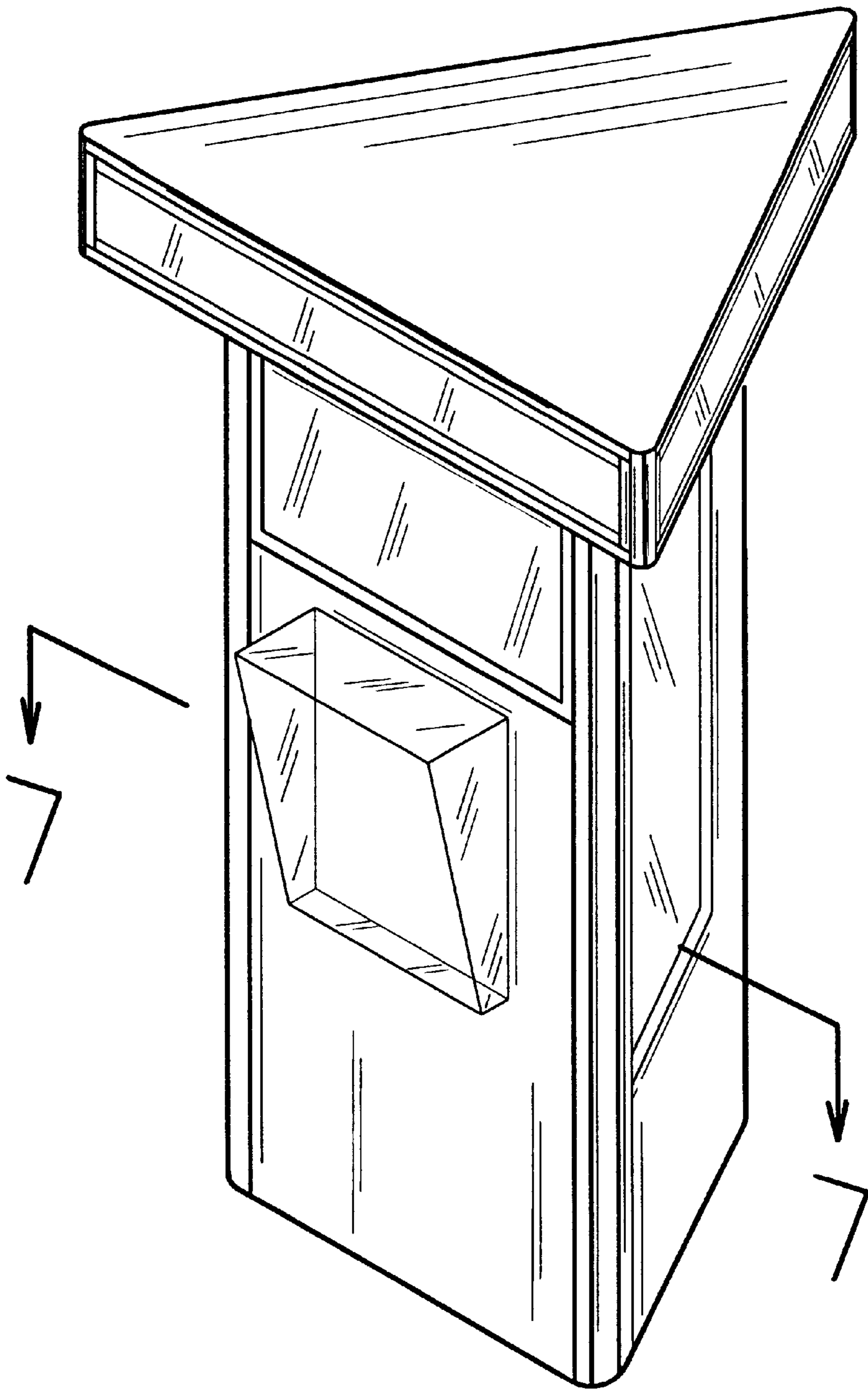

FIGURE 1

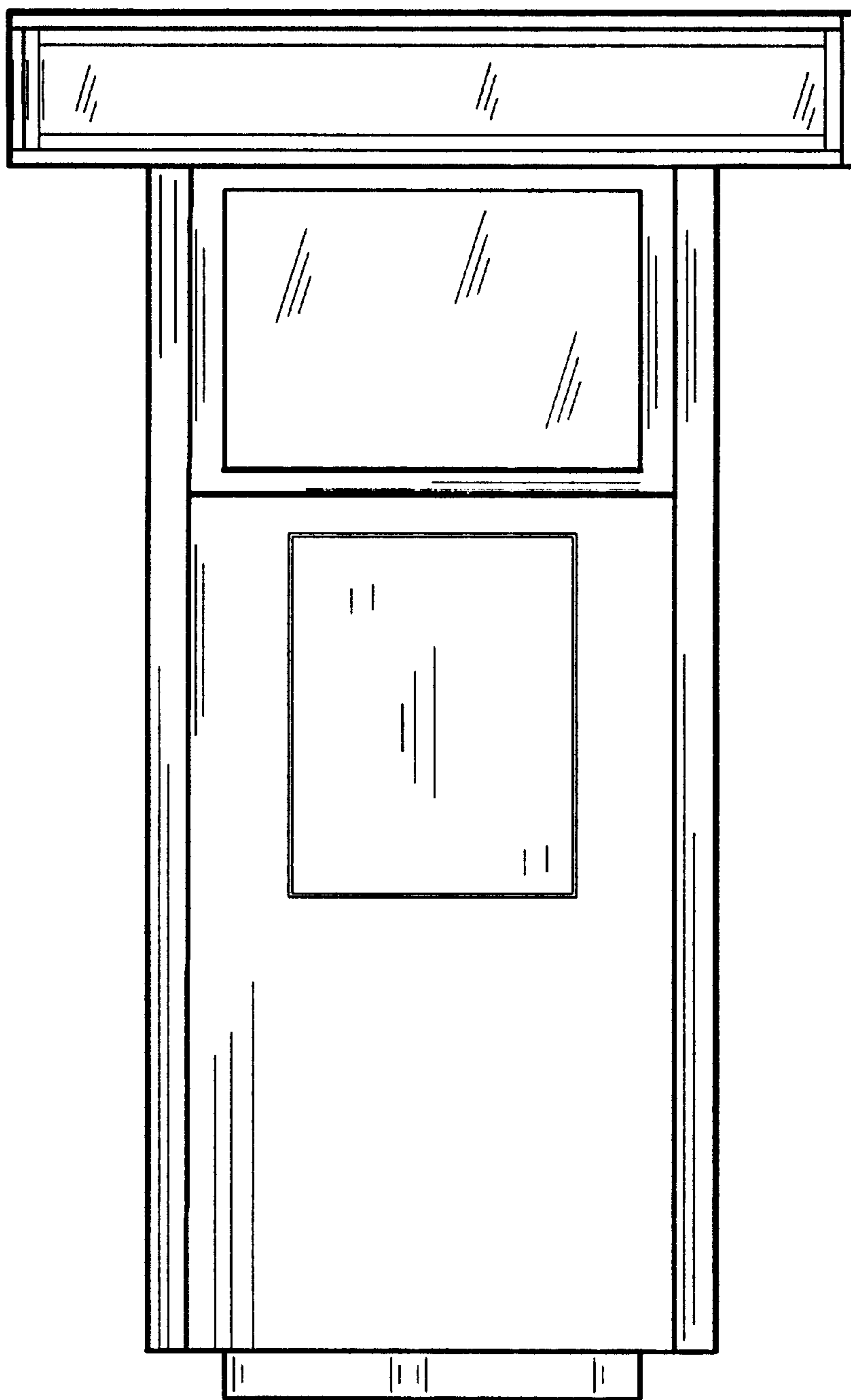

FIGURE 2

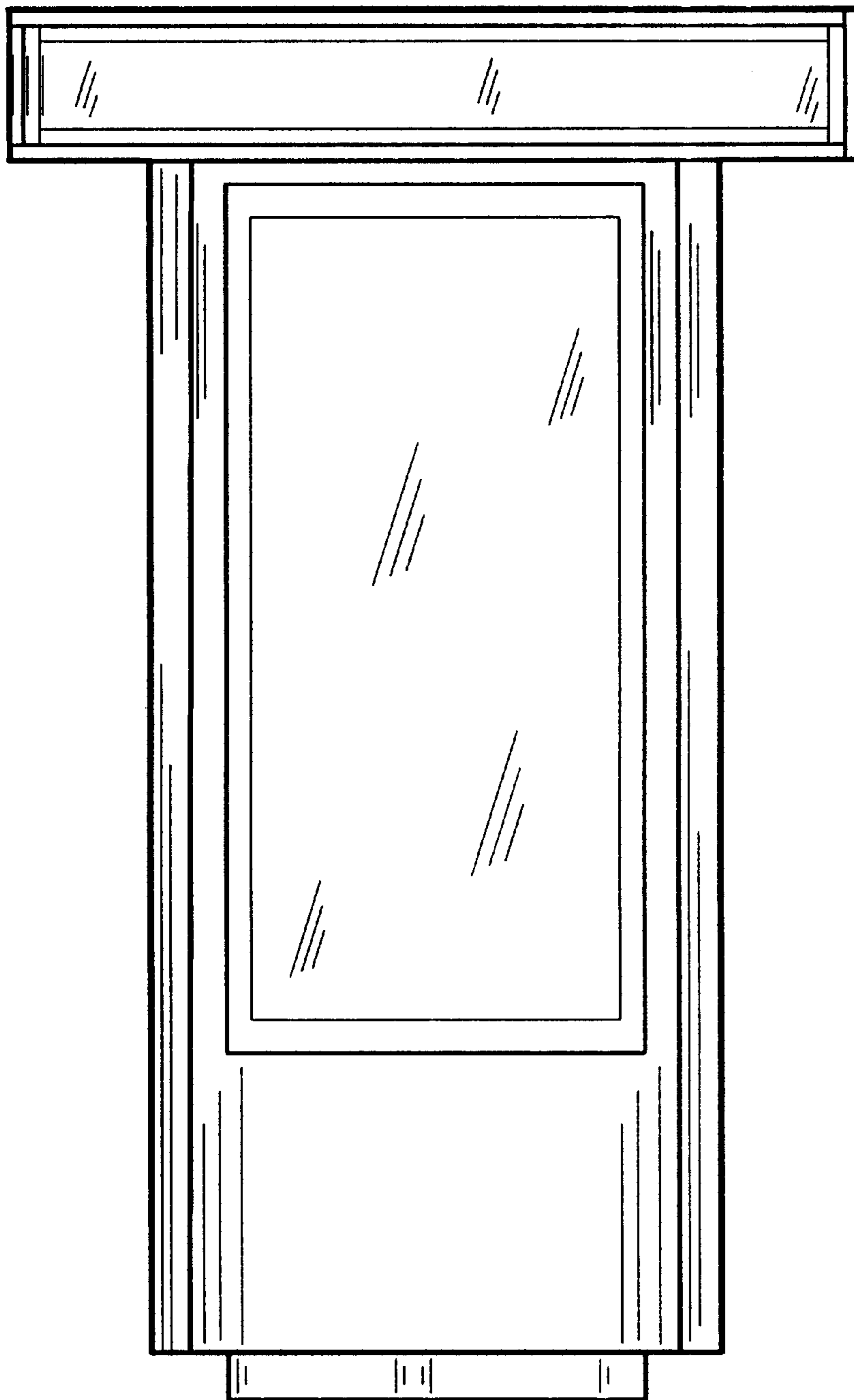

FIGURE 3

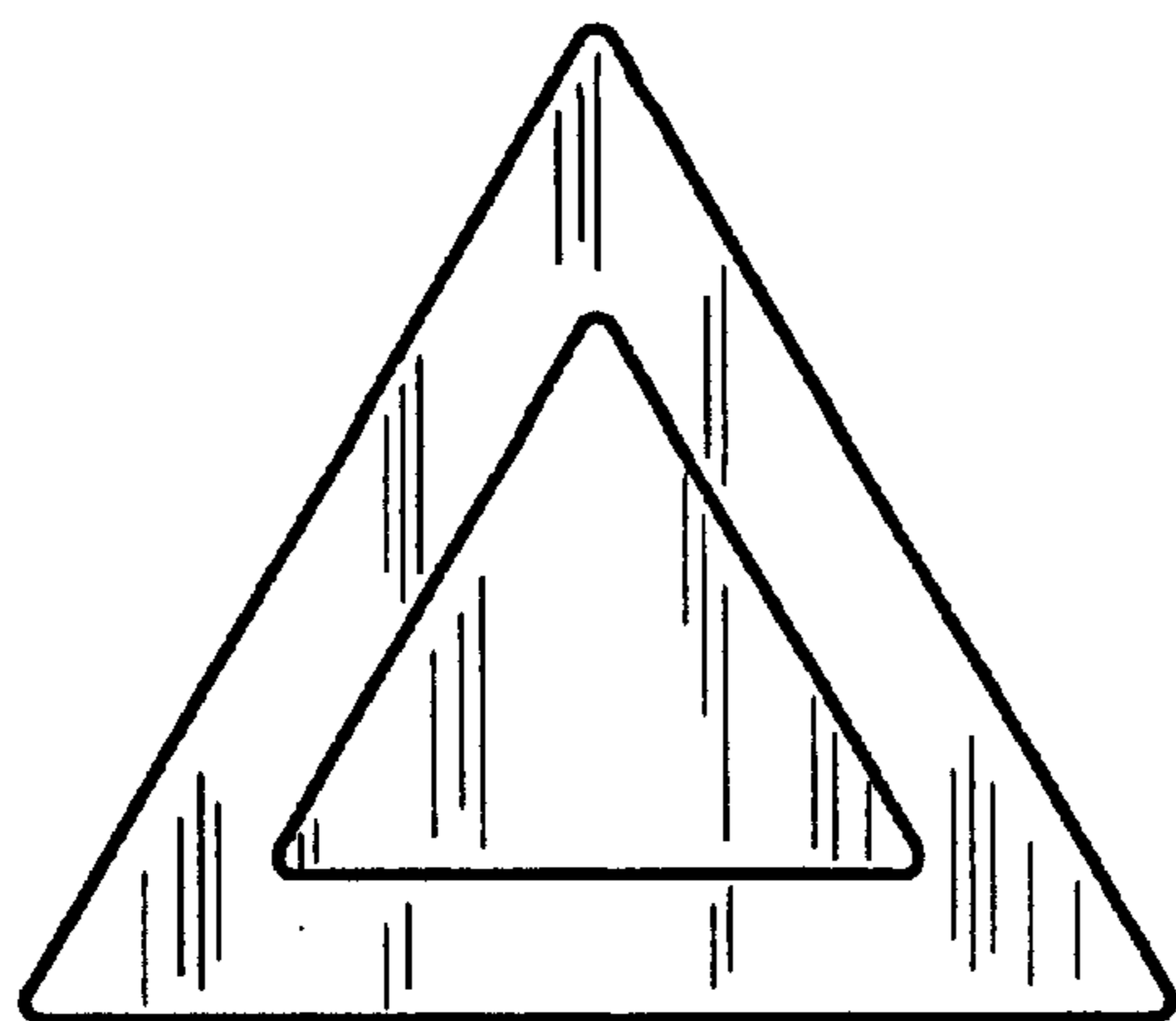

FIGURE 4

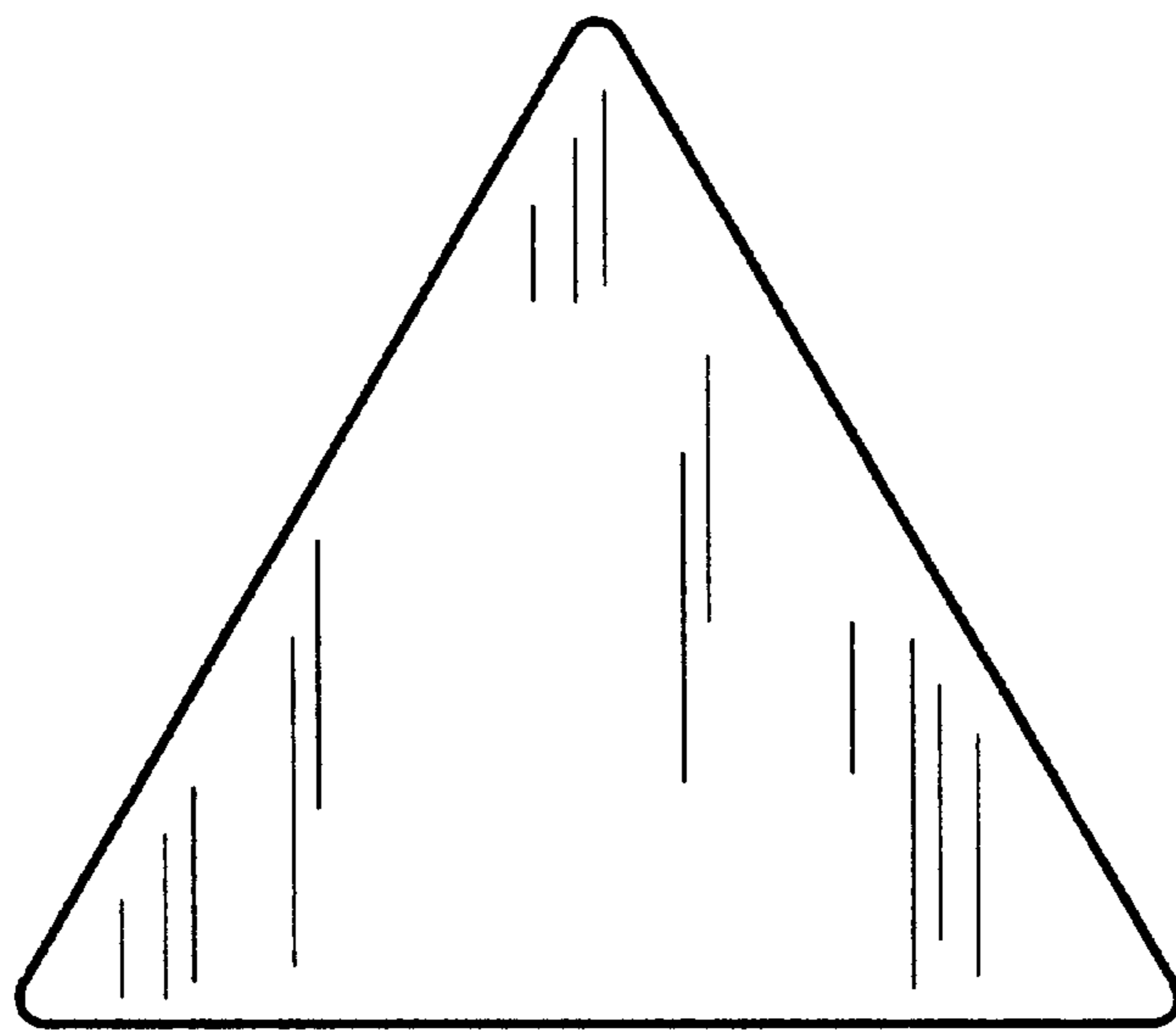

FIGURE 5

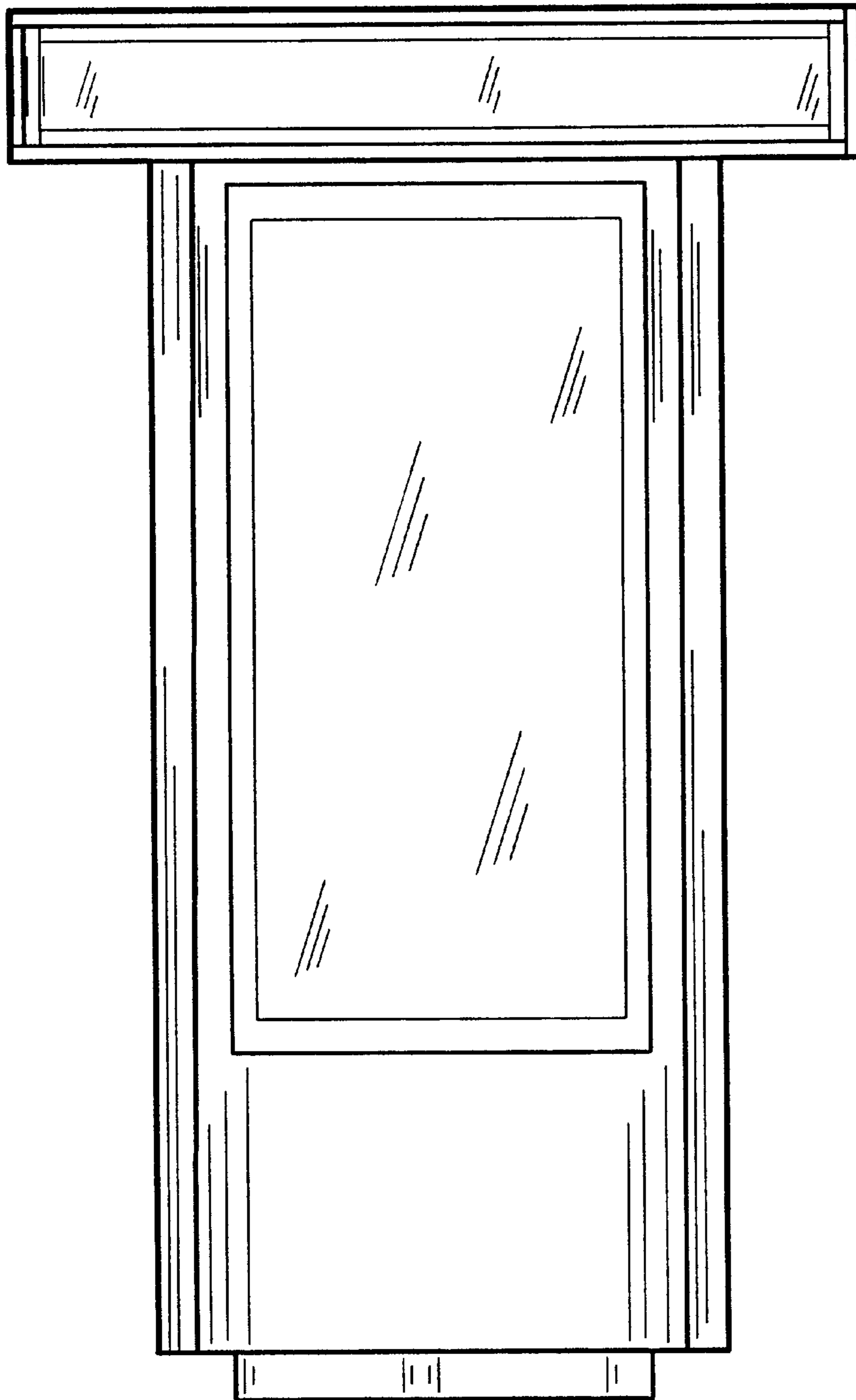

FIGURE 6

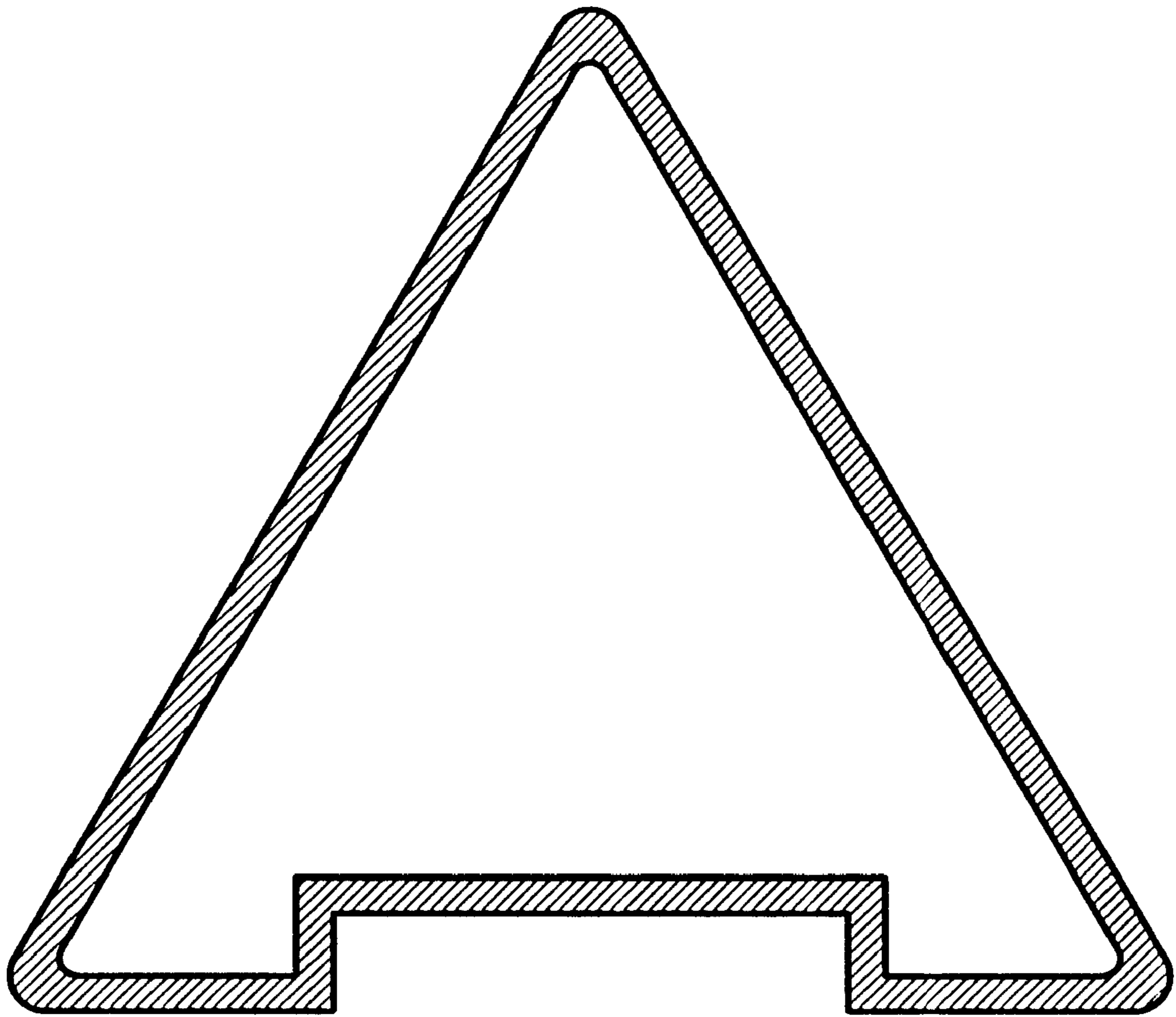

FIGURE 7

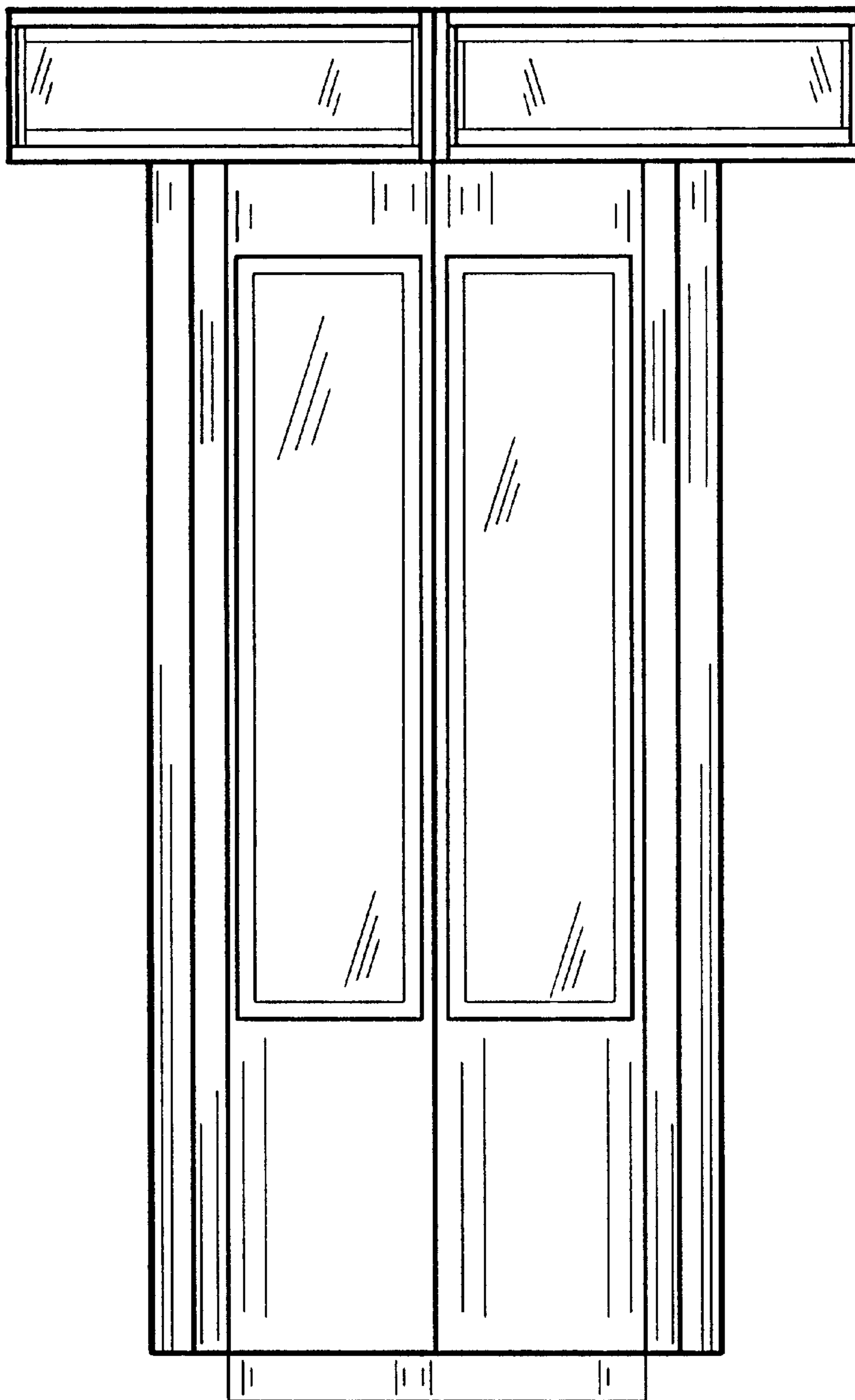

FIGURE 8