



US00D409544S

United States Patent [19]

[11] **Patent Number: Des. 409,544**

Voss et al.

[45] **Date of Patent: ** May 11, 1999**

[54] **OUTER SURFACE OF A VEHICLE FRONT**

[75] Inventors: **Karl Robert Voss**, Slinger, Wis.;
Daniel Robert Nickles, Hewitt, N.J.

[73] Assignee: **Deere & Company**, Moline, Ill.

[**] Term: **14 Years**

[21] Appl. No.: **29/083,514**

[22] Filed: **Jan. 29, 1998**

[51] **LOC (6) Cl.** **12-16**

[52] **U.S. Cl.** **D12/196**

[58] **Field of Search** D12/196, 14, 16,
D12/173; 180/69.2

[56] **References Cited**

U.S. PATENT DOCUMENTS

D. 316,696	5/1991	Haag et al.	D12/196
D. 326,831	6/1992	Janius et al.	D12/16
D. 337,747	7/1993	Henklen et al.	D12/15
D. 343,818	2/1994	DeBaal et al.	D12/173
D. 345,717	4/1994	Mohon et al.	D12/16
D. 364,590	11/1995	Yamashita	D12/14
D. 395,023	6/1998	Hikida	D12/16

OTHER PUBLICATIONS

Smithco, The new Runaway makes all other turf maintenance trucks obsolete, p. 1, dated Feb. 1989, published in U.S.A.

Jacobsen, Division of Textron Inc., 810 Express Utility Trucks, p. 1, date —unknown, published in U.S.A.

E-Z-Go, Division of Textron Inc., Turf Vehicles, p. 1, dated Sep. 1990, published in U.S.A.

Deere & Company, New Gator 6x4 and 4x2 Utility Vehicles, pp. 1-4, see particularly 1,2 and 3, dated Jan. 1993, published in U.S.A.

Deere & Company, John Deere AMT Transports, p. 1, dated Nov. 1988, published in U.S.A.

The Toro Company, Workman 3000 Series, p. 1, dated 1992, published in U.S.A.

Cushman Ransomes Ryan, Cushman Turf Care, pp. 1-28, see particularly p. 4, dated Feb. 1994, published in U.S.A.

Primary Examiner—Melody N Brown

[57] **CLAIM**

The ornamental design for an outer surface of a vehicle front, as shown and described.

DESCRIPTION

FIG. 1 is a left front elevated perspective view of an outer surface of a vehicle front, showing a first embodiment of our new design, the broken line showing of the vehicle is for illustrative purposes only, and forms no part of the claimed design.

FIG. 2 is a front view of the vehicle front outer surface design of FIG. 1.

FIG. 3 is a plan view of the vehicle front outer surface design of FIG. 1.

FIG. 4 is a right side view of the vehicle front outer surface design of FIG. 1.

FIG. 5 is a left side view of the vehicle front outer surface design of FIG. 1.

FIG. 6 is a left front elevated perspective view of an outer surface of a vehicle front, showing a second embodiment of our new design, the broken line showing of the vehicle is for illustrative purposes only, and forms no part of the claimed design.

FIG. 7 is a front view of the vehicle front outer surface design of FIG. 6.

FIG. 8 is a plan view of the vehicle front outer surface design of FIG. 6.

FIG. 9 is a right side view of the vehicle front outer surface design of FIG. 6; and,

FIG. 10 is a left side view of the vehicle front outer surface design of FIG. 6.

1 Claim, 8 Drawing Sheets

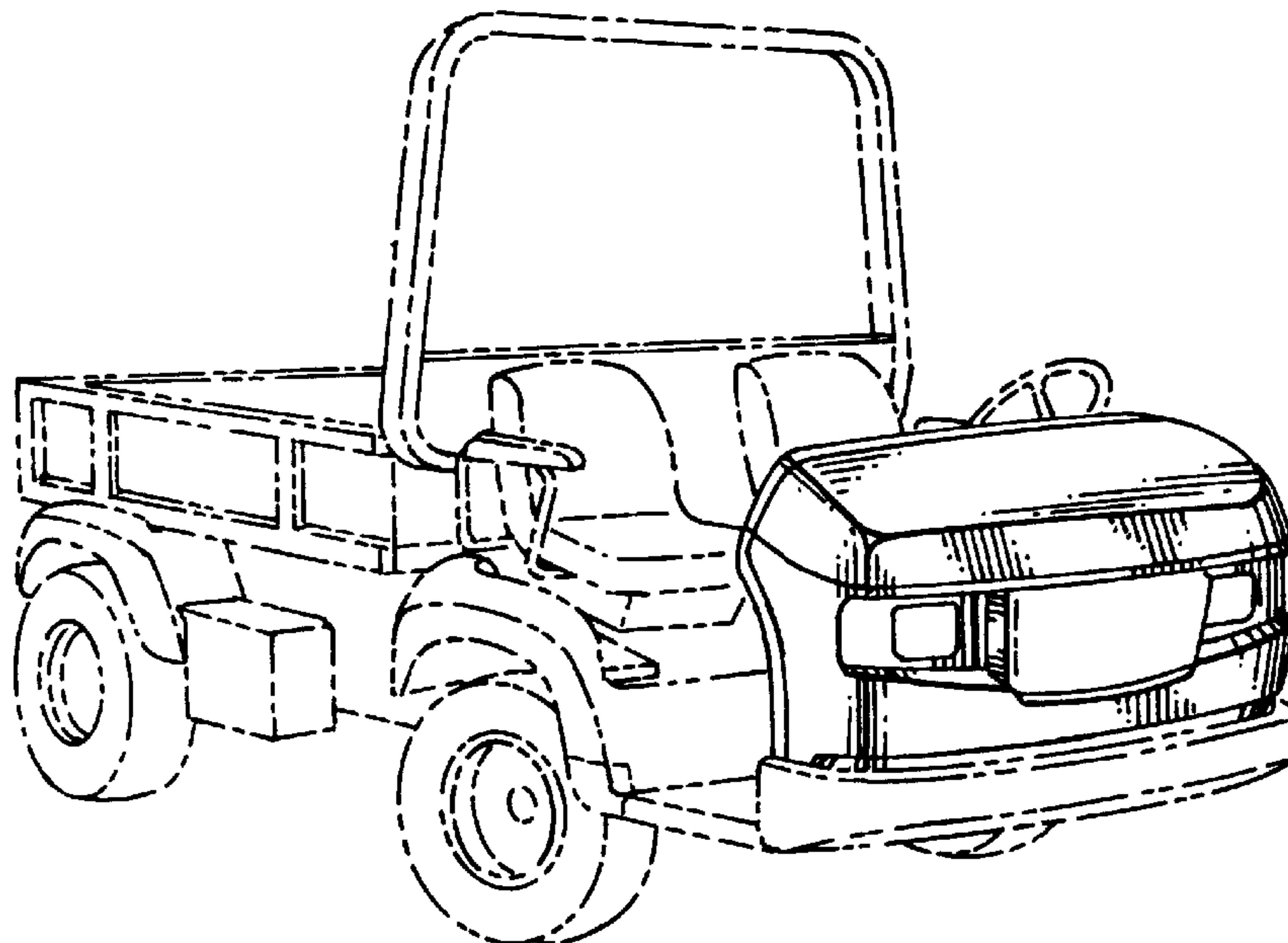
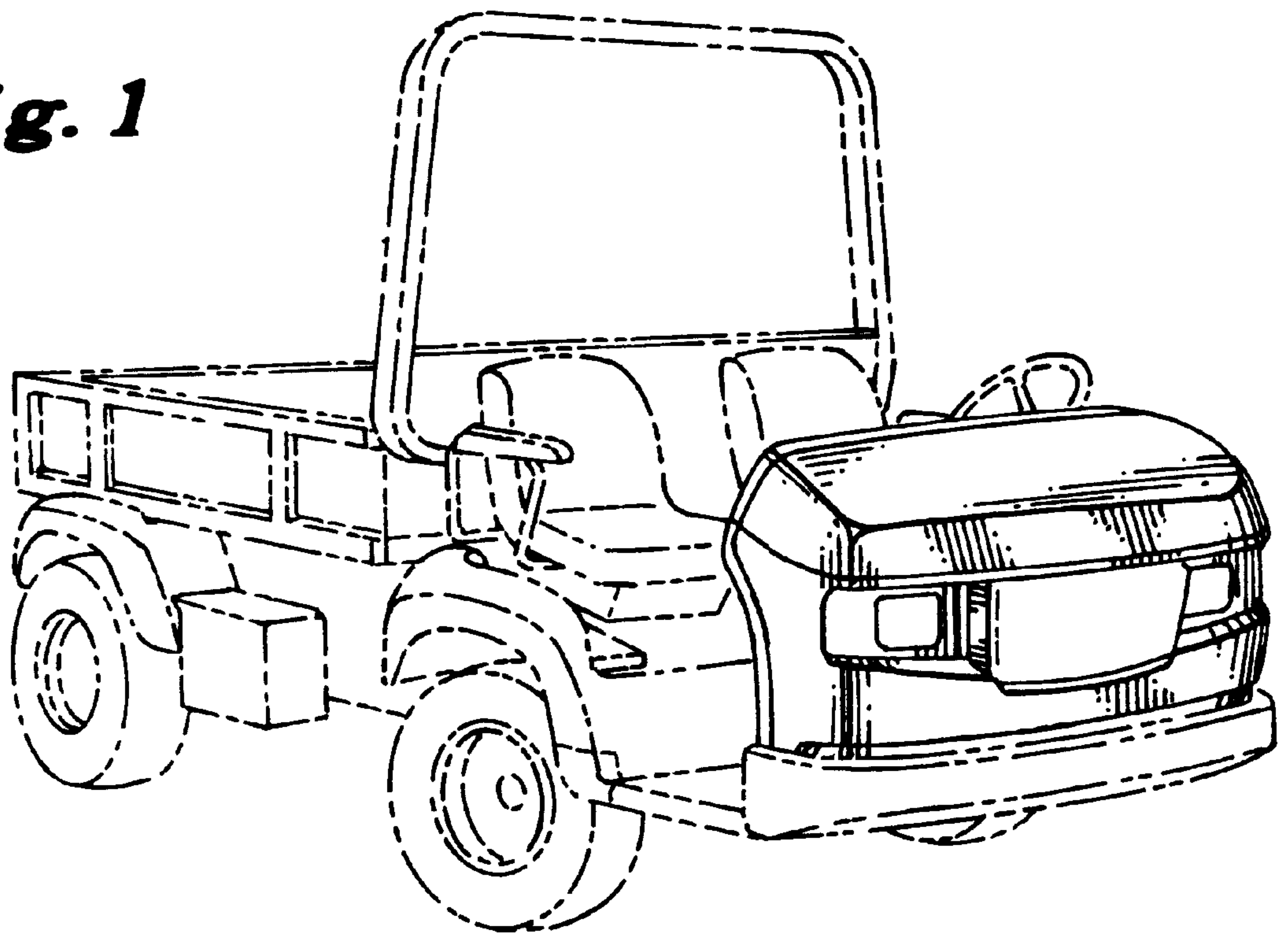

Fig. 1



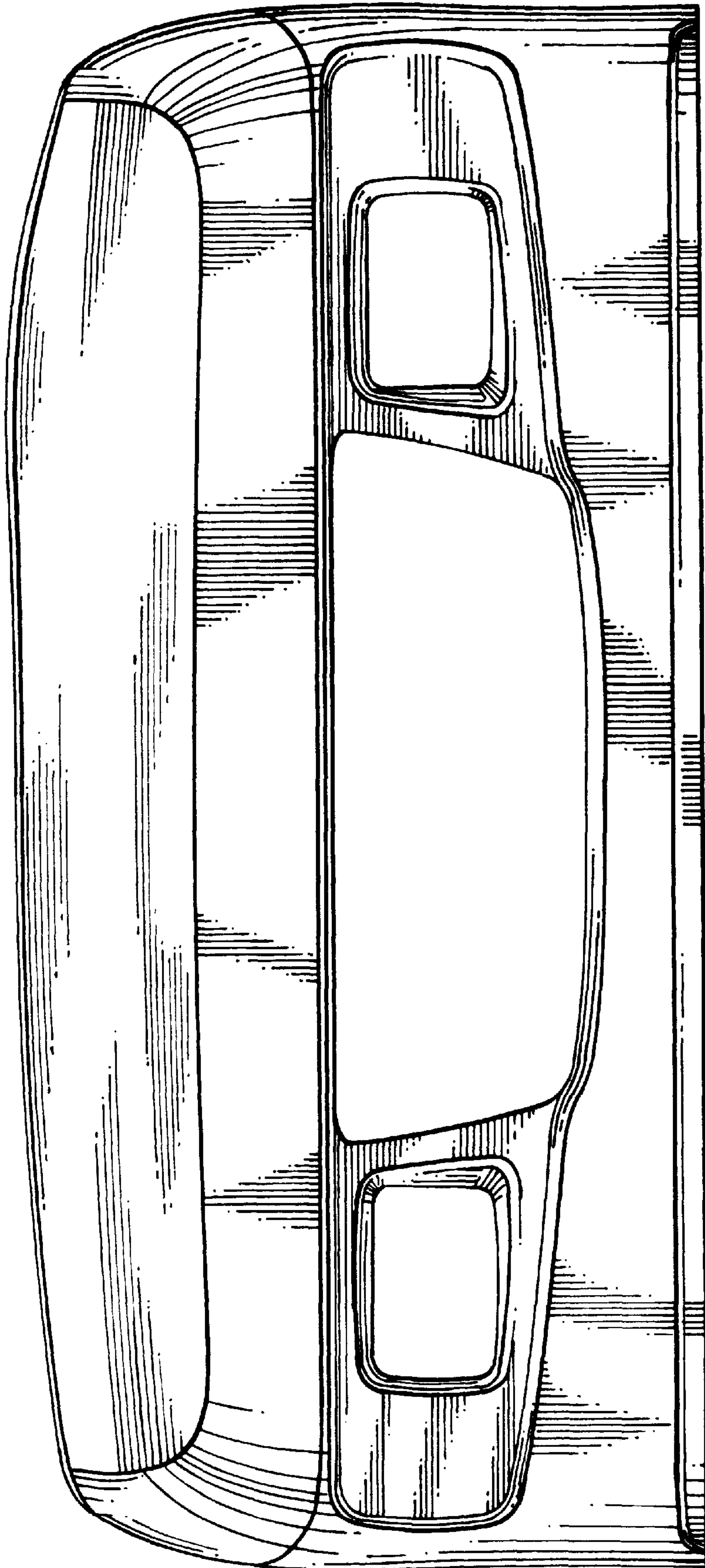

Fig. 2

Fig. 3



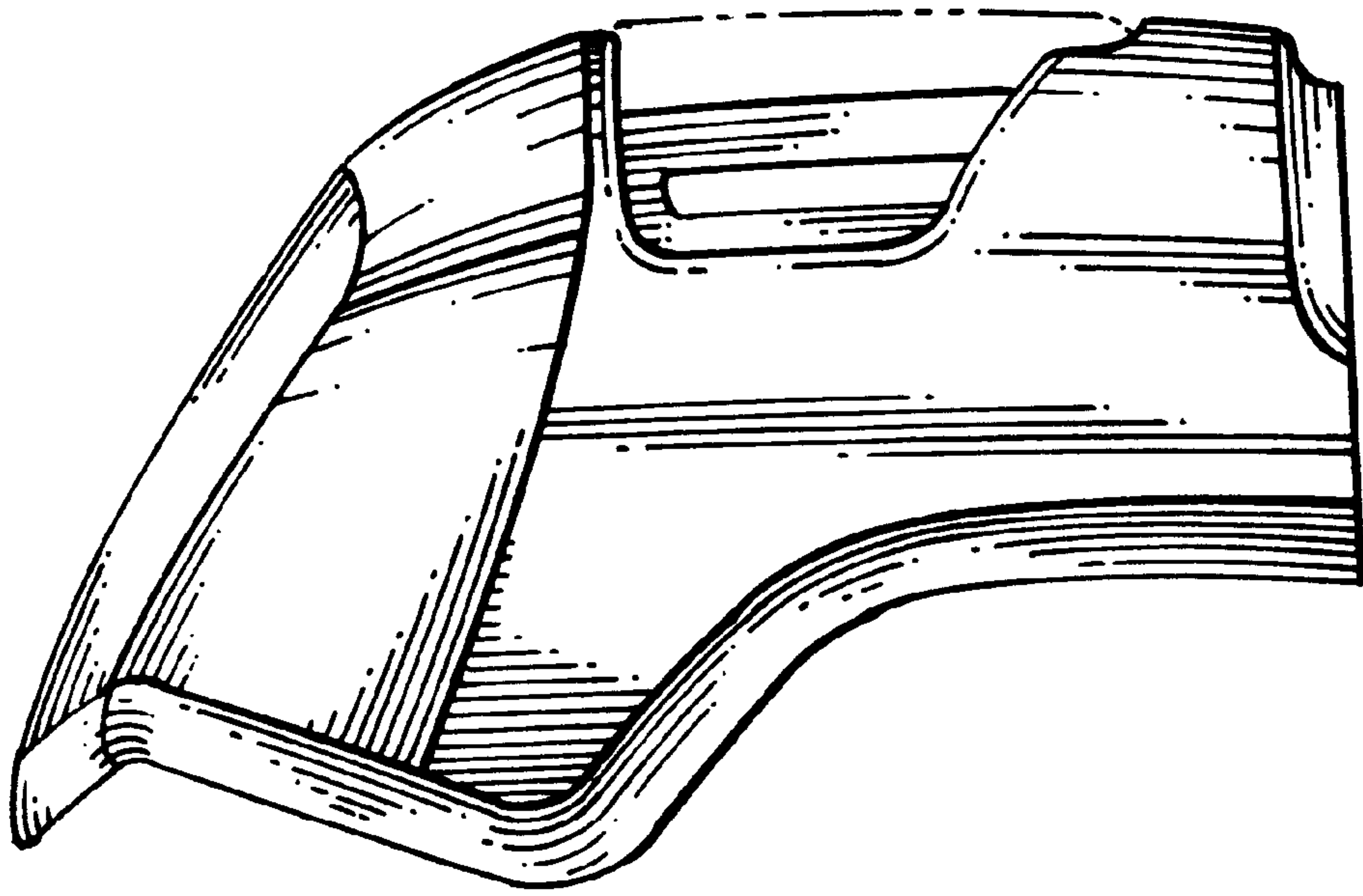

Fig. 5

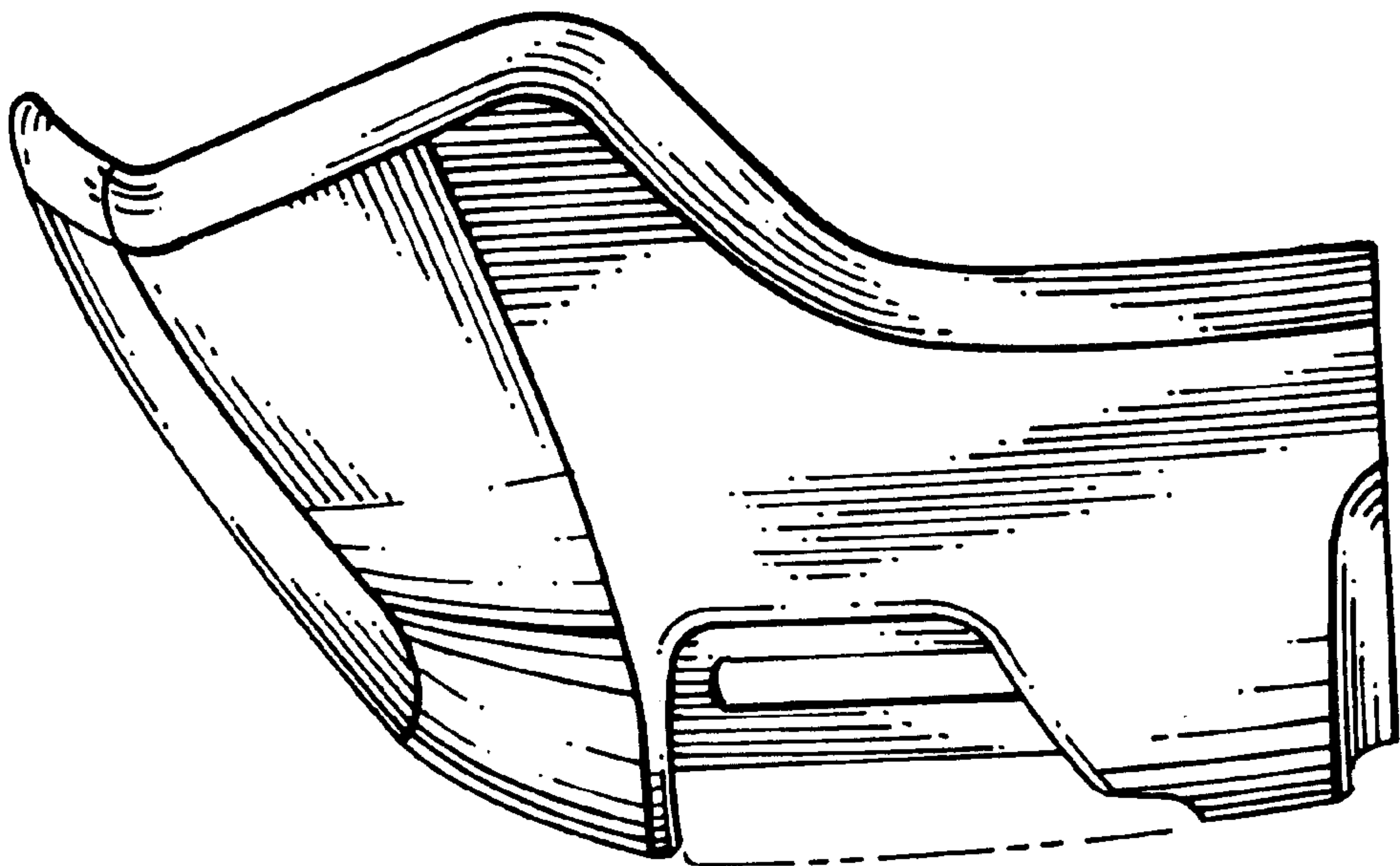
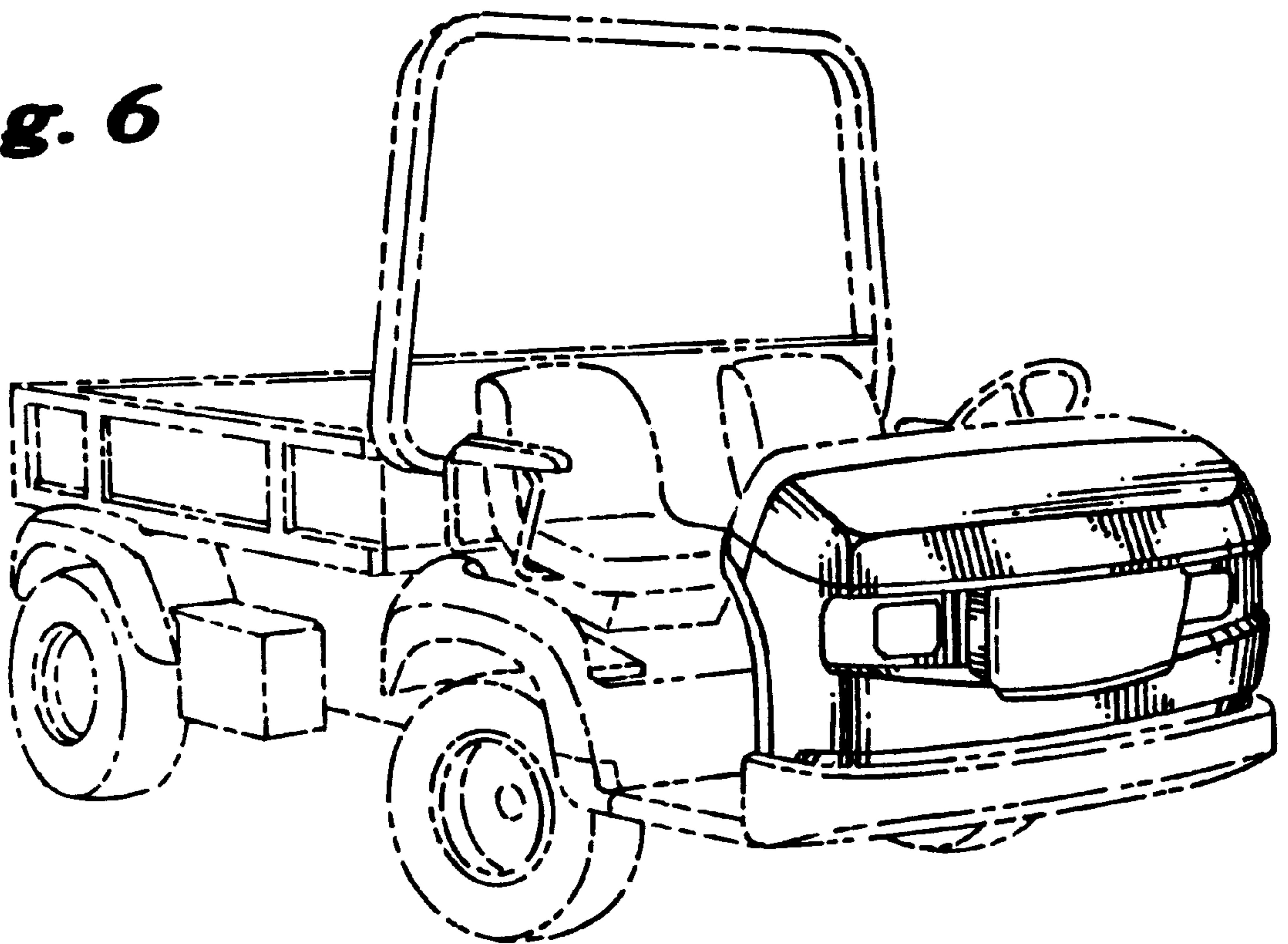

Fig. 4

Fig. 6



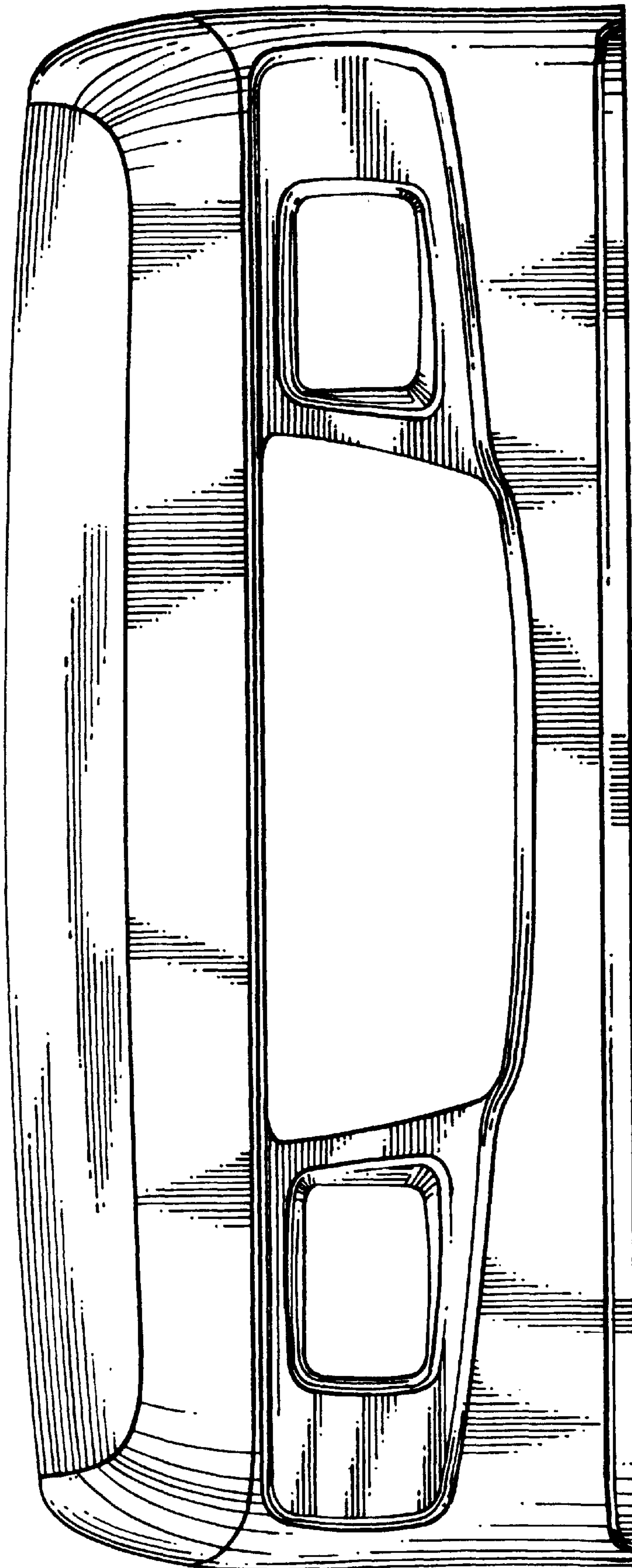
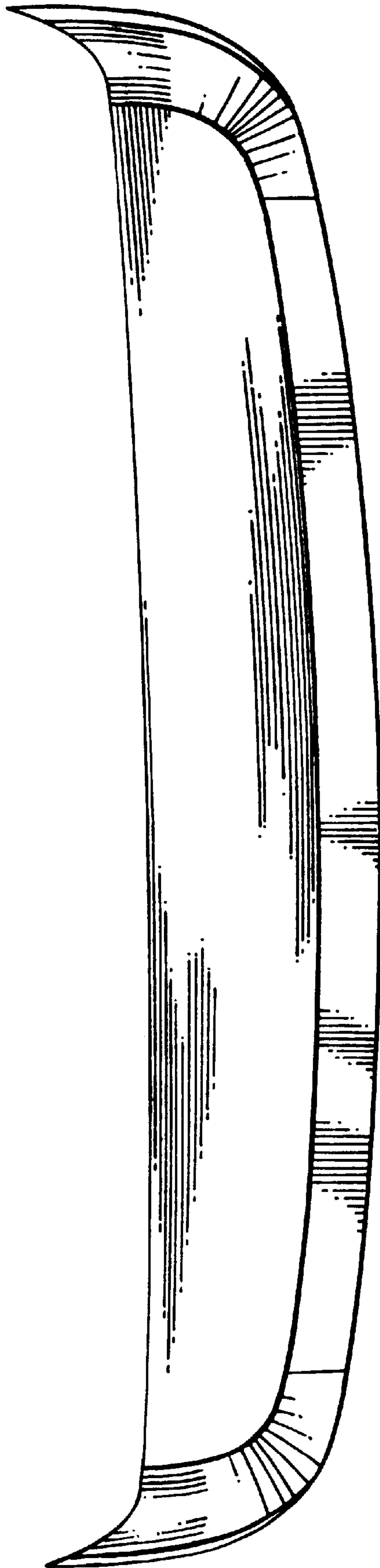

Fig. 7

Fig. 8



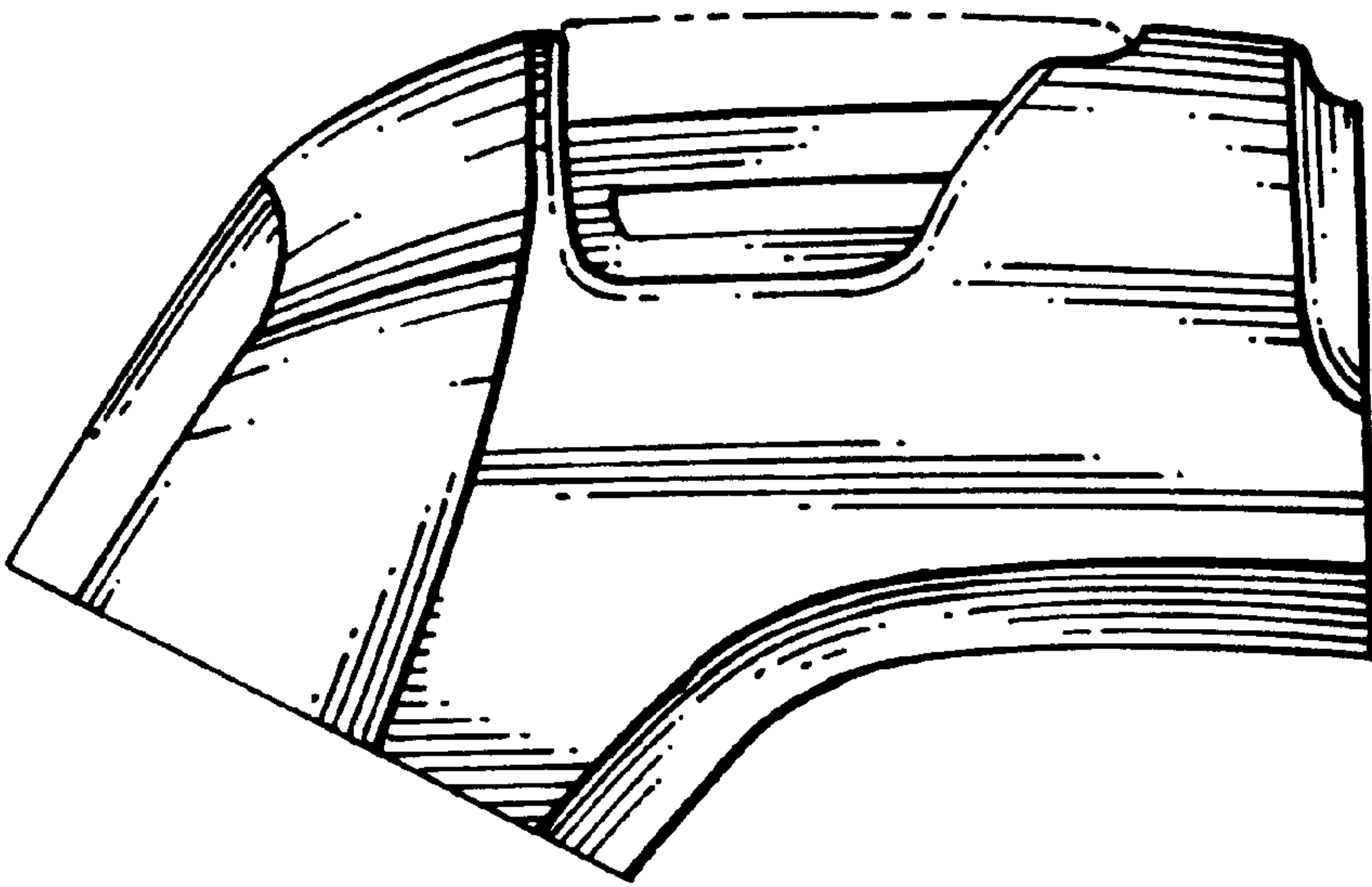

Fig. 10

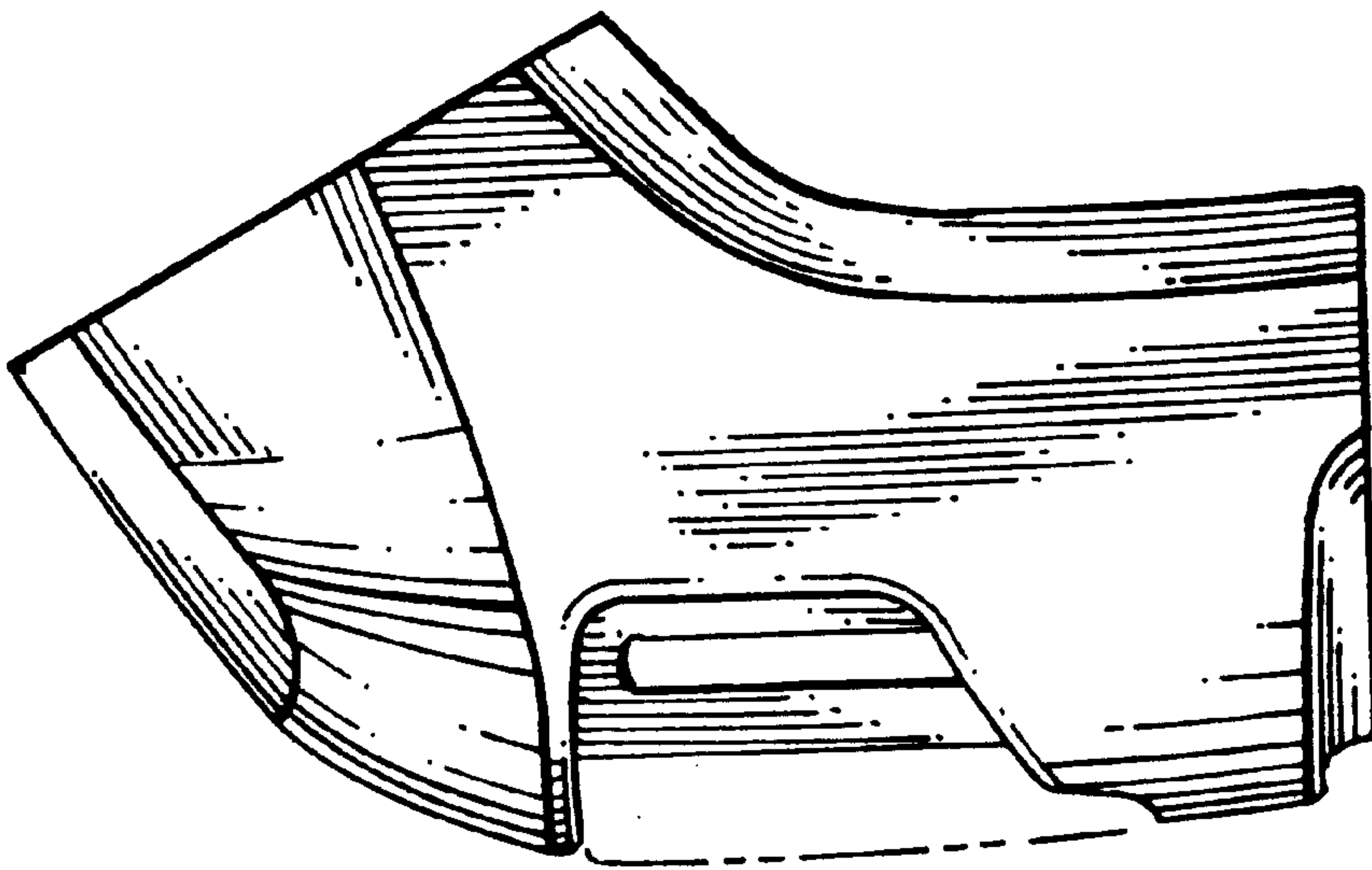

Fig. 9