



US00D409543S

# United States Patent [19]

Sutton et al.

[11] Patent Number: Des. 409,543

[45] Date of Patent: \*\* May 11, 1999

[54] INTERIOR OF A DOOR OF A TRUCK CAB

[75] Inventors: Robert A. Sutton, Clarkston; John B. Delphia, White Lake; Robert W. Anderson, Detroit, all of Mich.

[73] Assignee: Navistar International Transportation Corp., Chicago, Ill.

[\*\*] Term: 14 Years

[21] Appl. No.: 29/082,833

[22] Filed: Jan. 28, 1998

[51] LOC (6) Cl. .... 12-16

[52] U.S. Cl. .... D12/195

[58] Field of Search ..... D12/190, 195; 49/501, 502; 296/37.13, 146.1, 149, 153

### [56] References Cited

#### U.S. PATENT DOCUMENTS

|            |         |                        |         |
|------------|---------|------------------------|---------|
| D. 319,812 | 9/1991  | Tisten et al. ....     | D12/195 |
| D. 382,528 | 8/1997  | Hellhake et al. ....   | D12/195 |
| D. 387,024 | 12/1997 | Hellhake et al. ....   | D12/195 |
| 3,782,036  | 1/1974  | Clark et al. ....      | 49/502  |
| 5,542,738  | 8/1996  | Walker et al. ....     | 49/502  |
| 5,584,144  | 12/1996 | Hisano ....            | 296/153 |
| 5,822,927  | 10/1998 | Hellenkamp et al. .... | 49/502  |

#### OTHER PUBLICATIONS

Brochure AD-42546C from Navistar International Transportation Corp. 1998.

Primary Examiner—Robert M. Spear

Attorney, Agent, or Firm—Dennis Kelly Sullivan; Jeffrey P. Calfa

### [57] CLAIM

The ornamental design for an interior of a door of a truck cab, as shown and described.

### DESCRIPTION

FIG. 1 is a right, front perspective view of a left door embodiment of an interior of a door of a truck cab showing our new design, it may be understood that the broken lines on all figures are for illustrative purposes only and form no part of the claimed design;

FIG. 2 is a side view of the embodiment of the invention shown in FIG. 1;

FIG. 3 is a top view of the embodiment of the invention shown in FIG. 1;

FIG. 4 is a front view of the embodiment of the invention shown in FIG. 1;

FIG. 5 is a rear view of the embodiment of the invention shown in FIG. 1;

FIG. 6 is a left, front perspective view of a right door embodiment of an interior of a door of a truck cab showing our new design;

FIG. 7 is a side view of the embodiment of the invention shown in FIG. 6;

FIG. 8 is a top view of the embodiment of the invention shown in FIG. 6;

FIG. 9 is a rear view of the embodiment of the invention shown in FIG. 6; and,

FIG. 10 is a front view of the embodiment of the invention shown in FIG. 6.

1 Claim, 6 Drawing Sheets

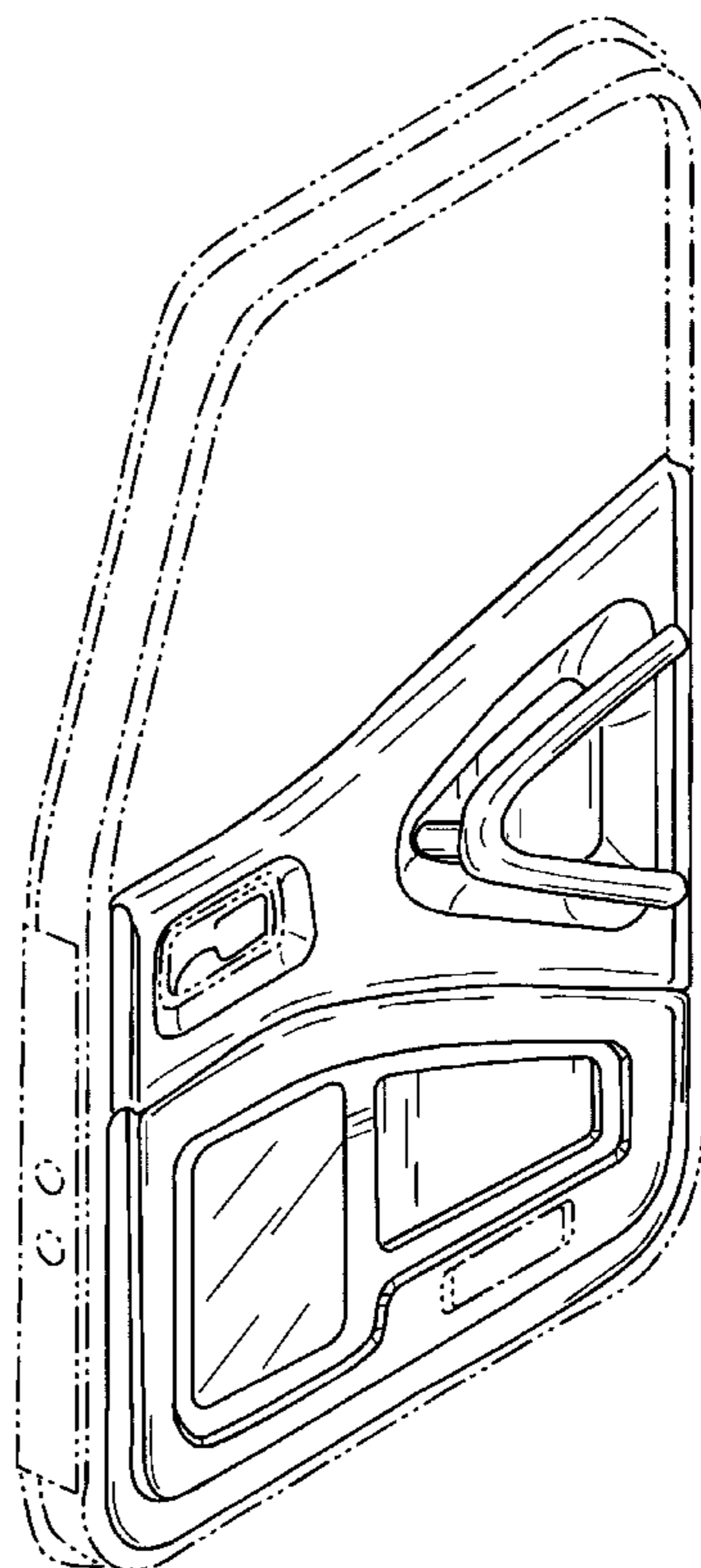
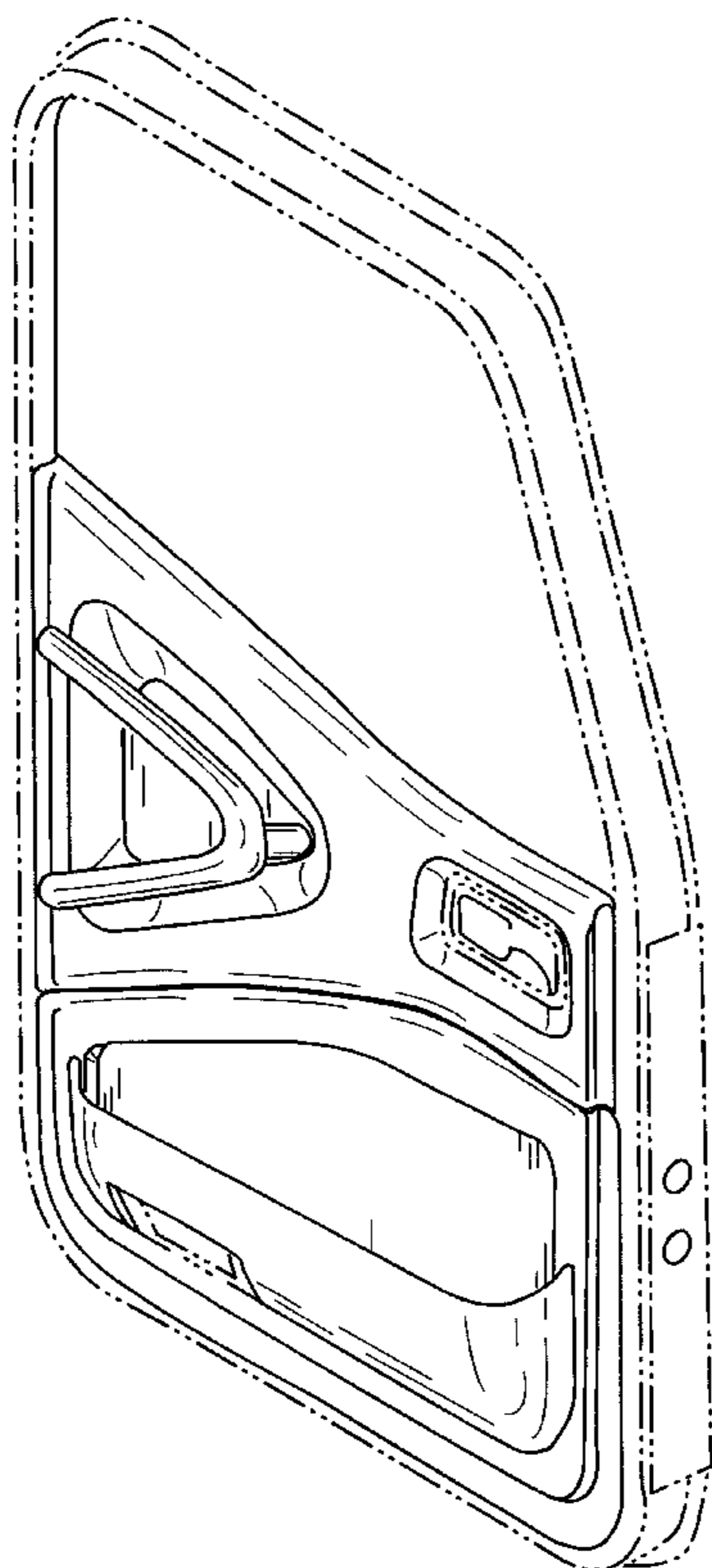

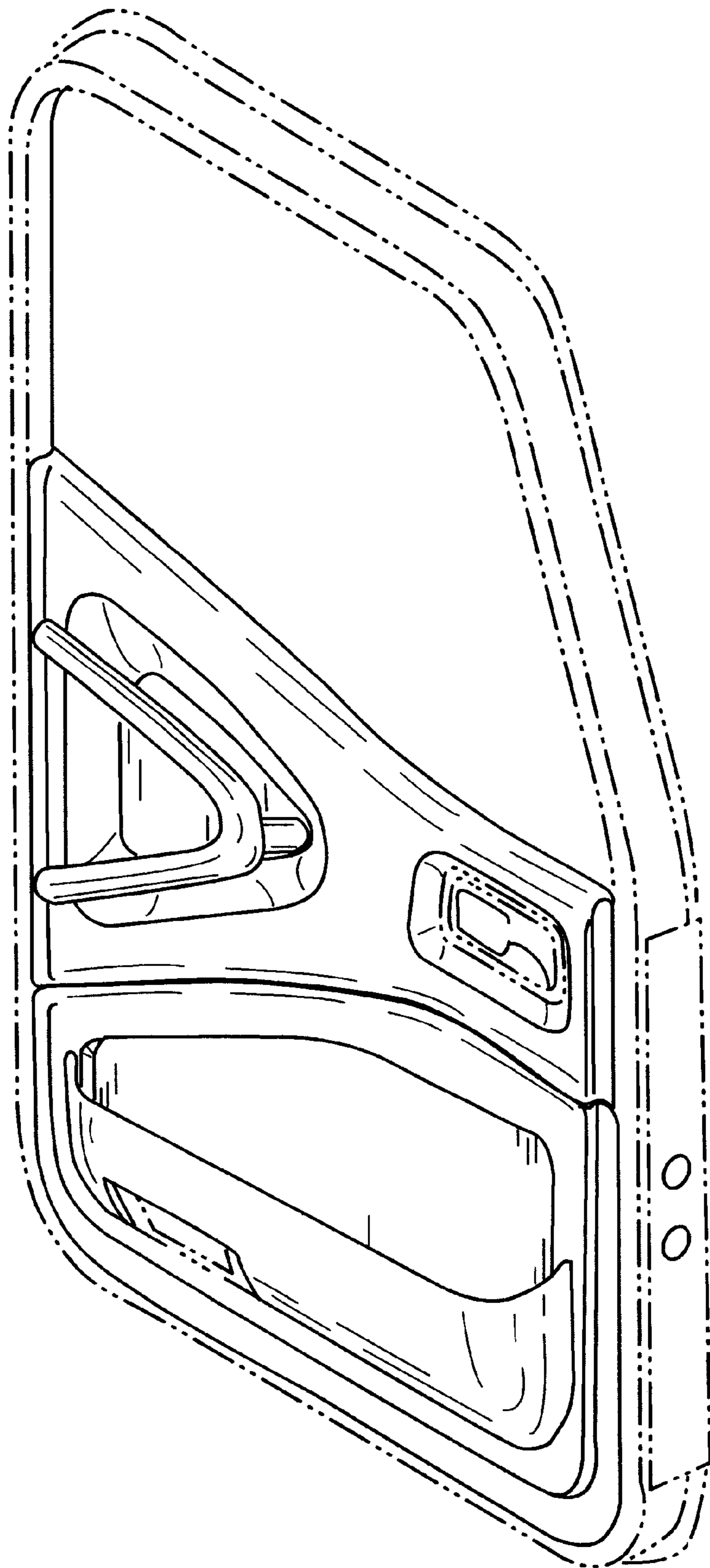

Fig. 1

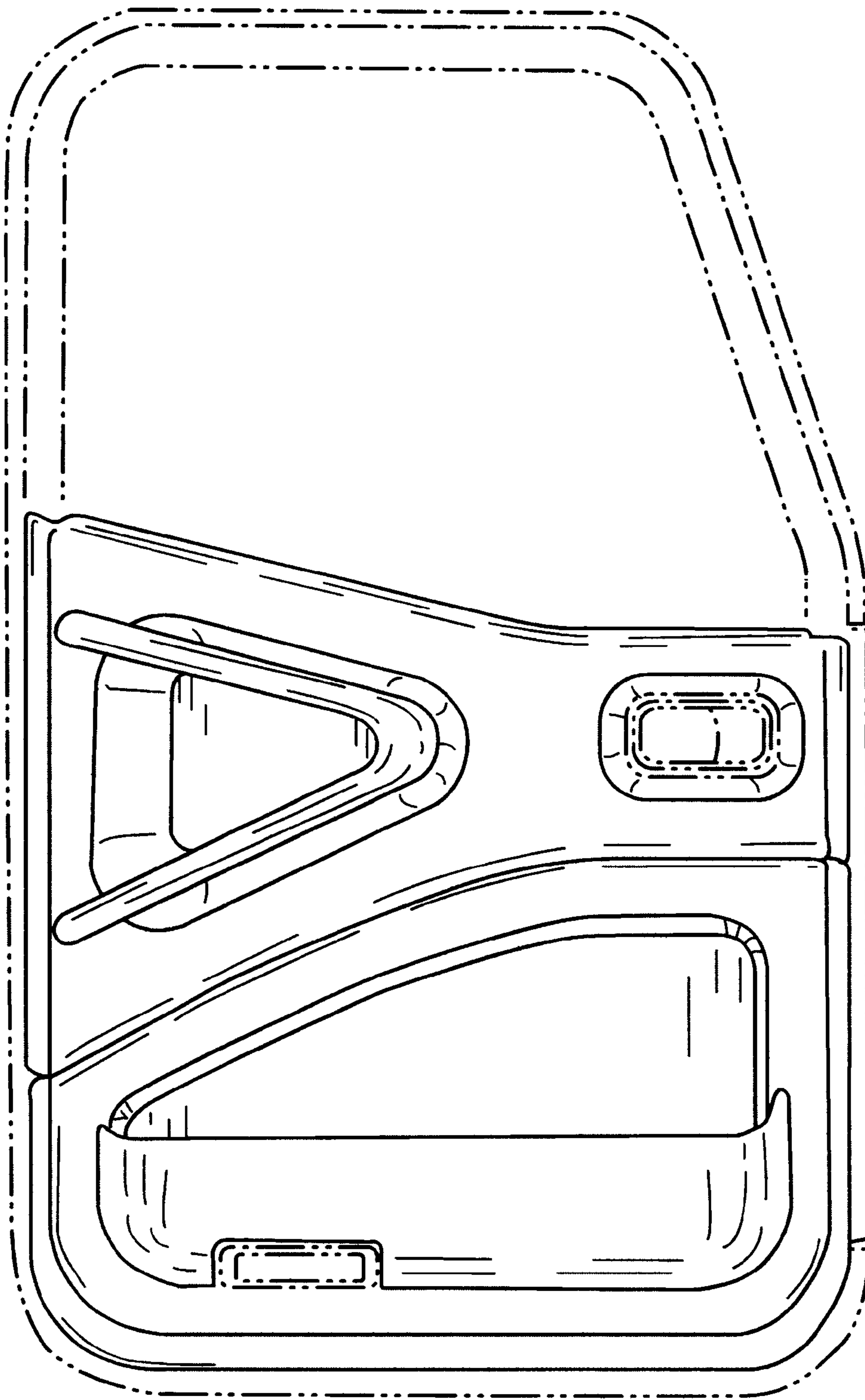

Fig. 2

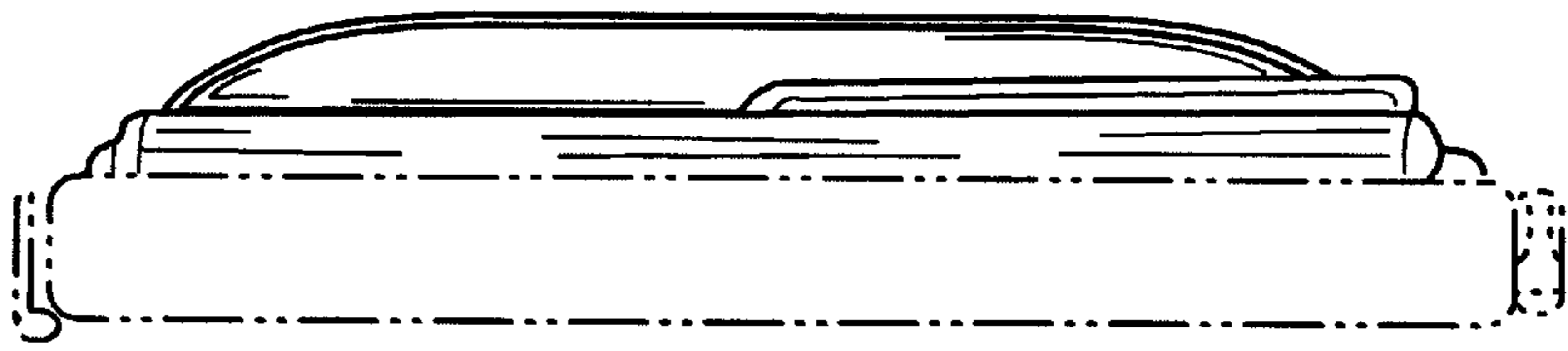

Fig. 3

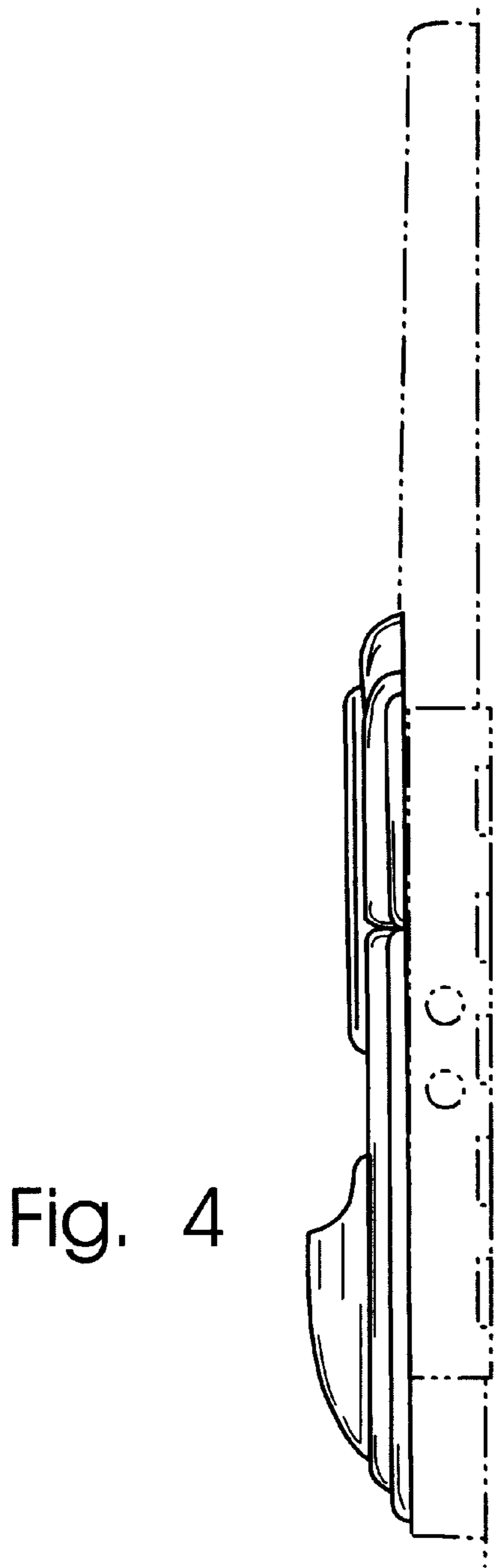

Fig. 4

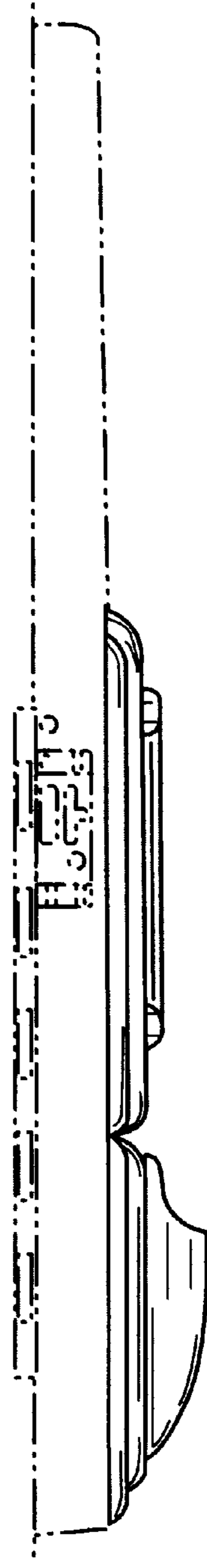

Fig. 5

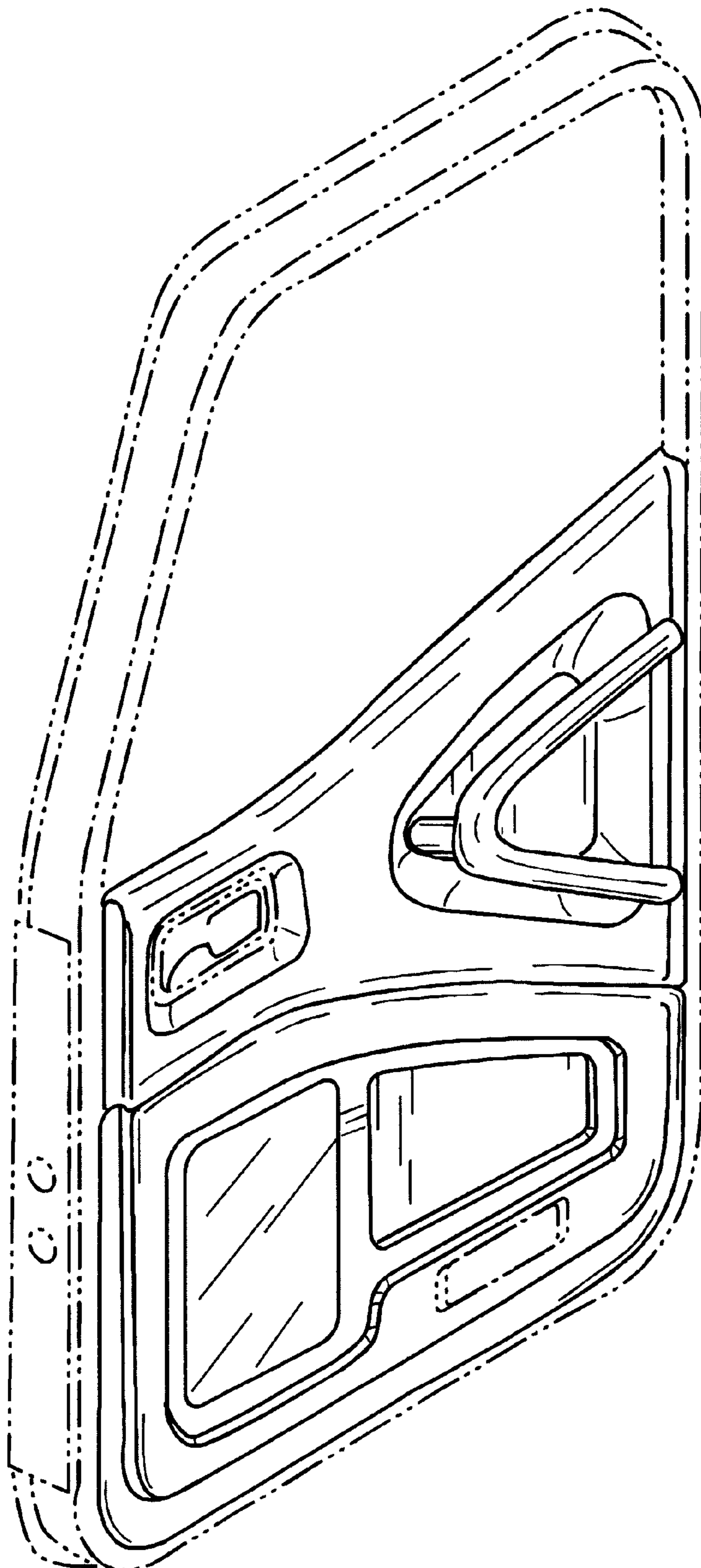

Fig. 6

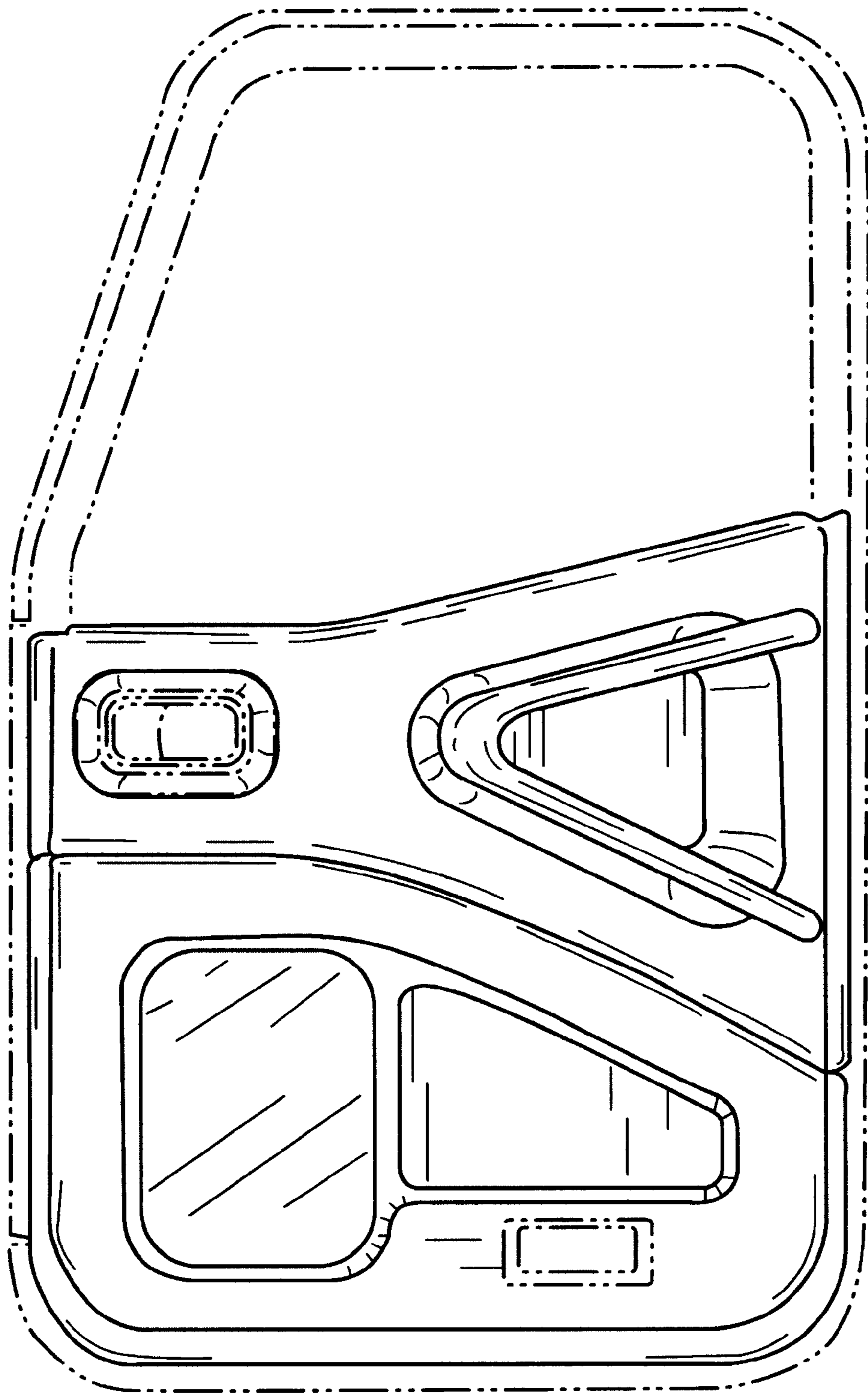

Fig. 7

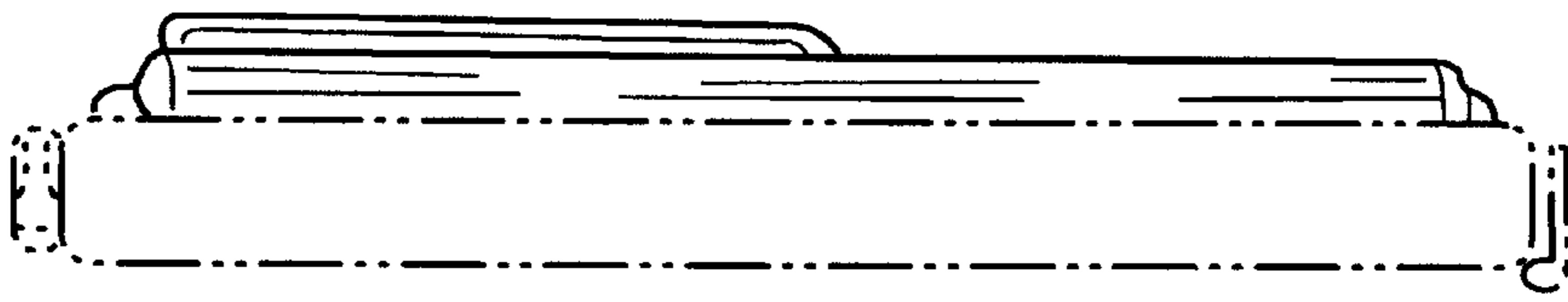

Fig. 8

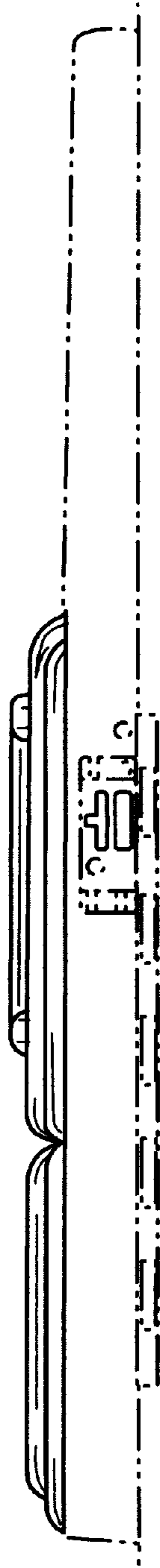

Fig. 9

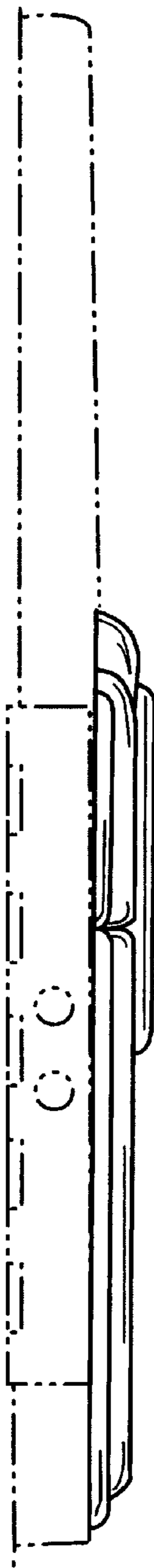

Fig. 10