



US00D409469S

# United States Patent [19]

Niwa et al.

[11] Patent Number: **Des. 409,469**

[45] Date of Patent: **\*\* May 11, 1999**

[54] **PORTABLE ELECTRIC JIG SAW**

[75] Inventors: **Norifumi Niwa, Anjo; Masamichi Miyazawa, Kariya, both of Japan**

[73] Assignee: **Makita Corporation, Aichi, Japan**

[\*\*] Term: **14 Years**

[21] Appl. No.: **29/091,531**

[22] Filed: **Jul. 31, 1998**

[30] **Foreign Application Priority Data**

Feb. 10, 1998 [JP] Japan ..... 10-3543

[51] **LOC (6) Cl.** ..... **08-03**

[52] **U.S. Cl.** ..... **D8/69; D8/64**

[58] **Field of Search** ..... D8/61, 64, 68, D8/69; 30/374, 392-394, 272-273

[56] **References Cited**

**U.S. PATENT DOCUMENTS**

- D. 197,549 2/1964 Johnson .
- D. 262,472 12/1981 Wildman ..... D8/64 X
- D. 329,005 9/1992 Hoshino ..... D8/69
- D. 339,276 9/1993 Matsuoka et al. .... D8/64

- 3,087,519 4/1963 McCarty .
- 3,863,342 2/1975 Griffles ..... 30/392 X
- 4,334,356 6/1982 Krosunger ..... 30/374
- 5,634,277 6/1997 Wada ..... 30/392

**OTHER PUBLICATIONS**

Makita Corporation Data Sheet for Jig Saw Model 4320, Feb. 1989.

*Primary Examiner*—Nelson C. Holtje  
*Attorney, Agent, or Firm*—Lahive & Cockfield, LLP

[57] **CLAIM**

The ornamental design for a portable electric jig saw, as shown and described.

**DESCRIPTION**

FIG. 1 is a perspective view of a portable electric jig saw shown my new design;  
FIG. 2 is a right side elevational view thereof;  
FIG. 3 is a left side elevational view thereof;  
FIG. 4 is a front elevational view thereof;  
FIG. 5 is a rear side elevational view thereof;  
FIG. 6 is a top plan view thereof; and,  
FIG. 7 is a bottom plan view thereof.

**1 Claim, 5 Drawing Sheets**

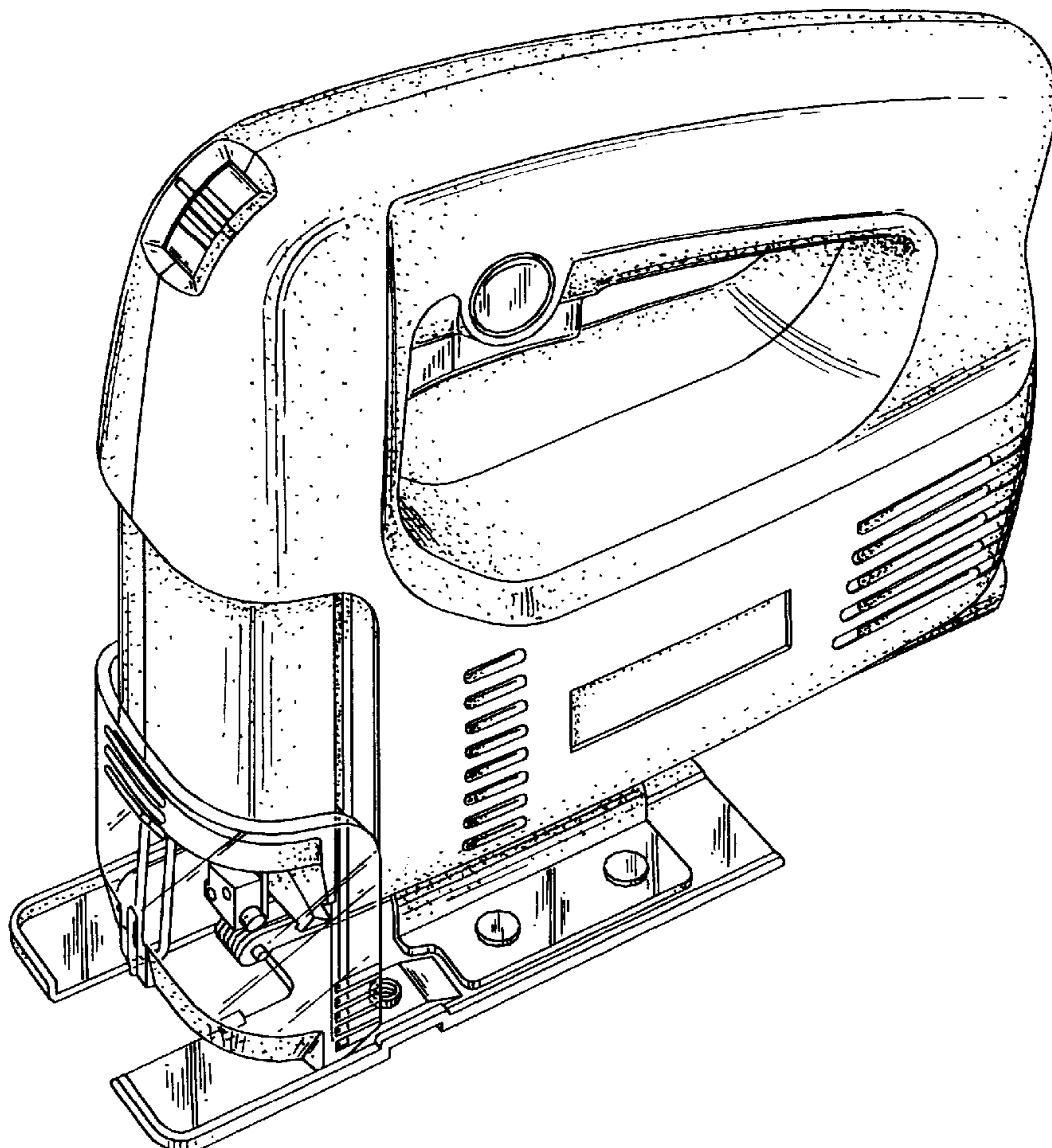

FIG. 1

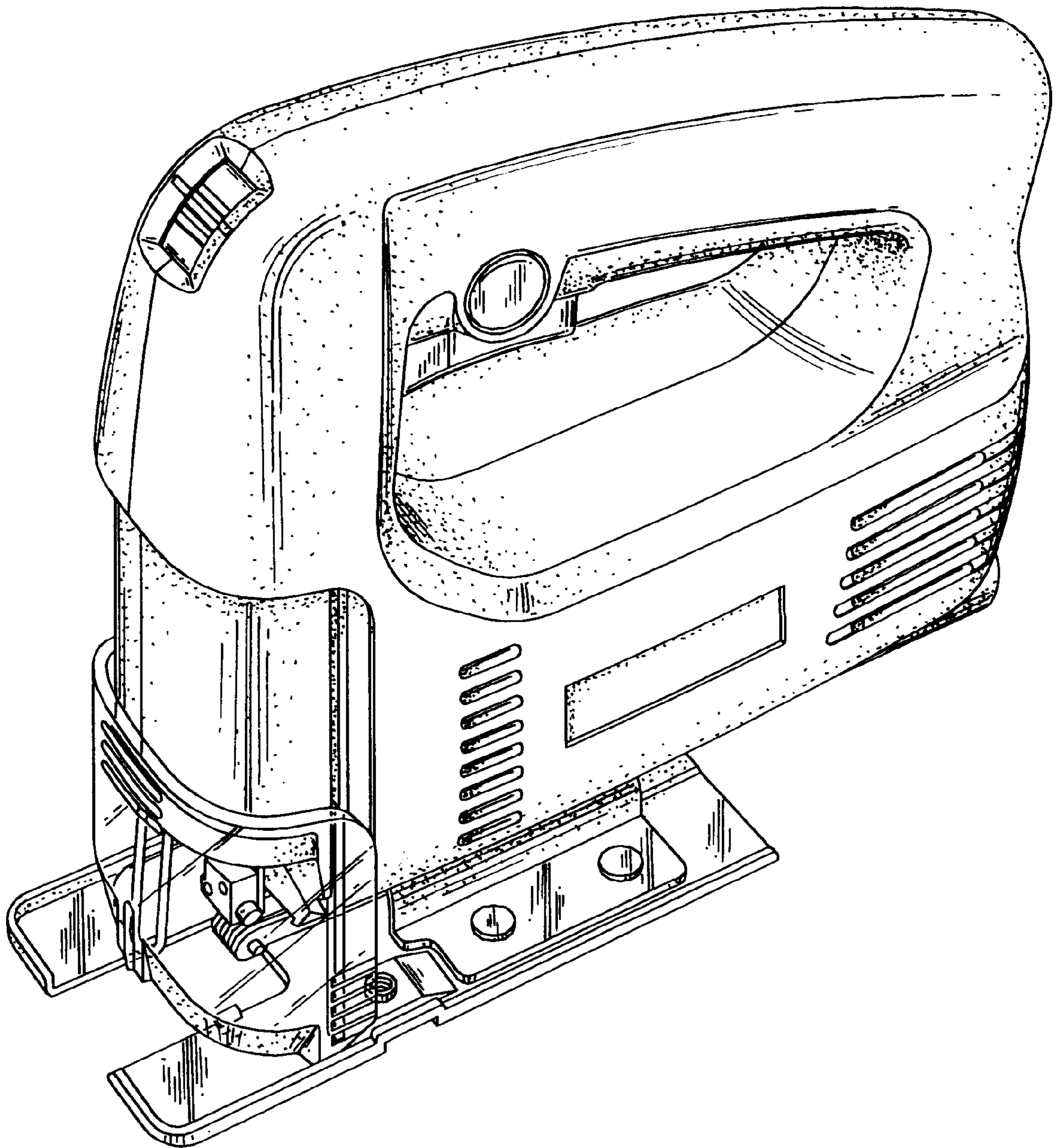

FIG. 2

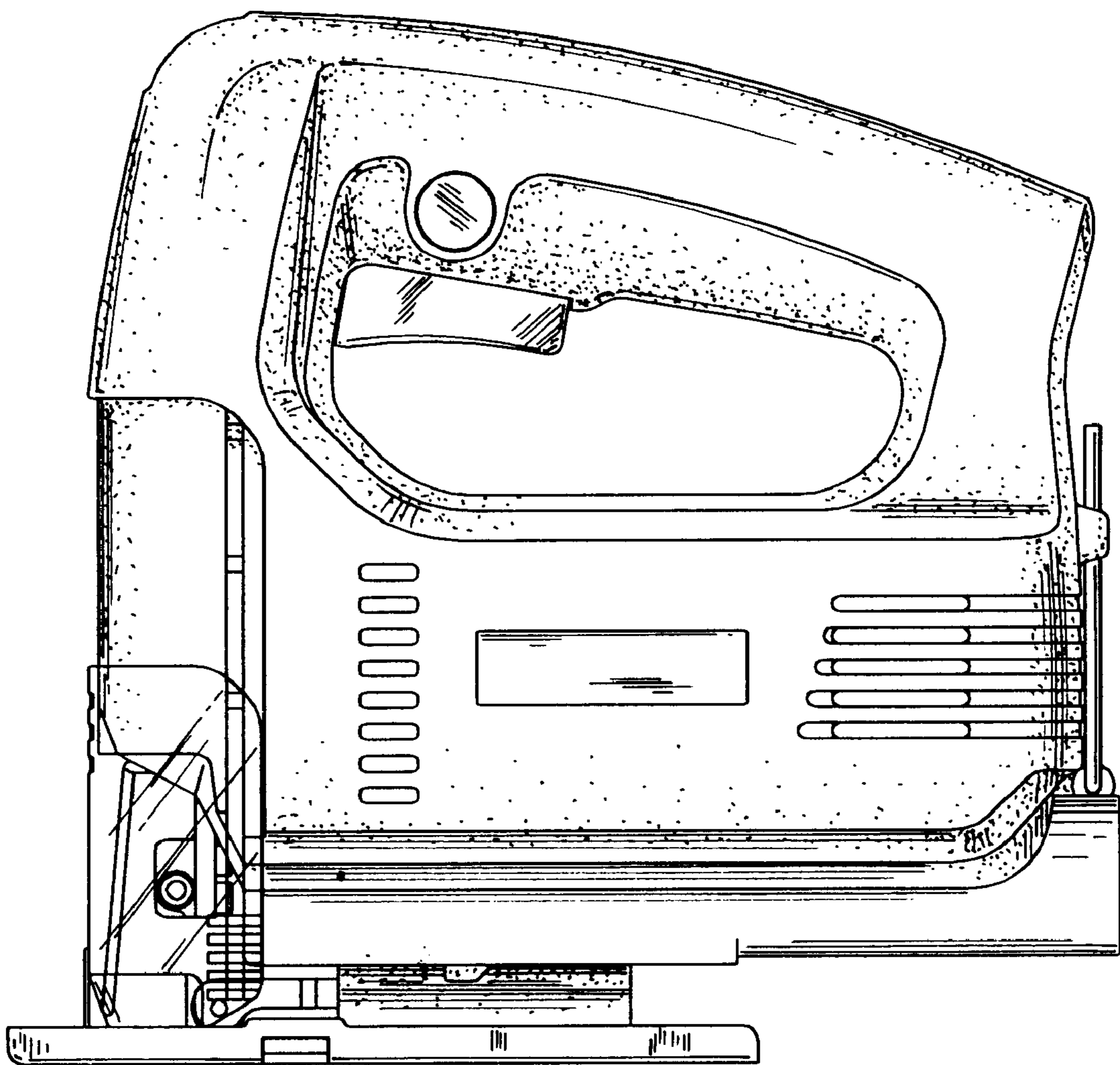

FIG. 3

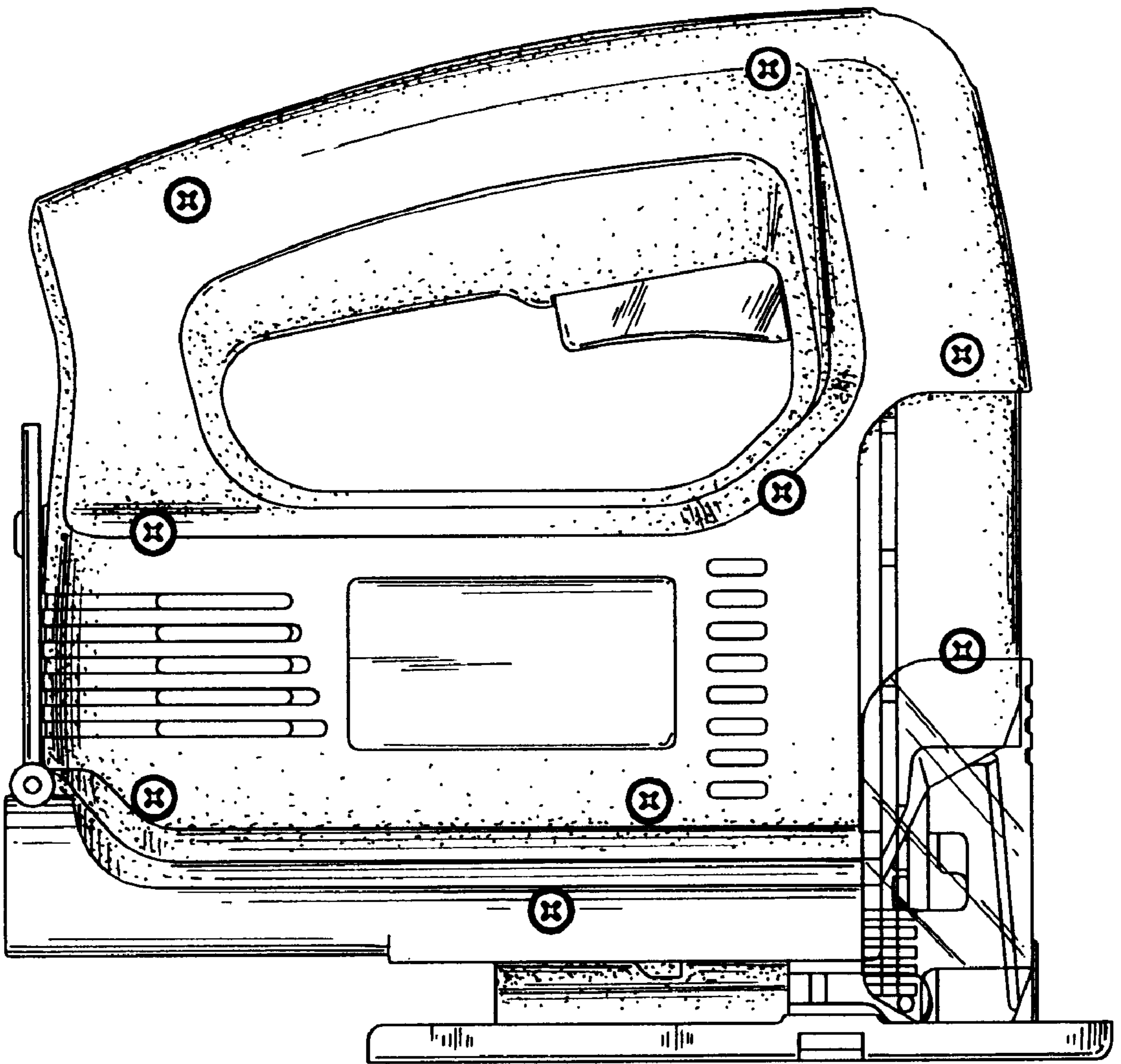

FIG. 4

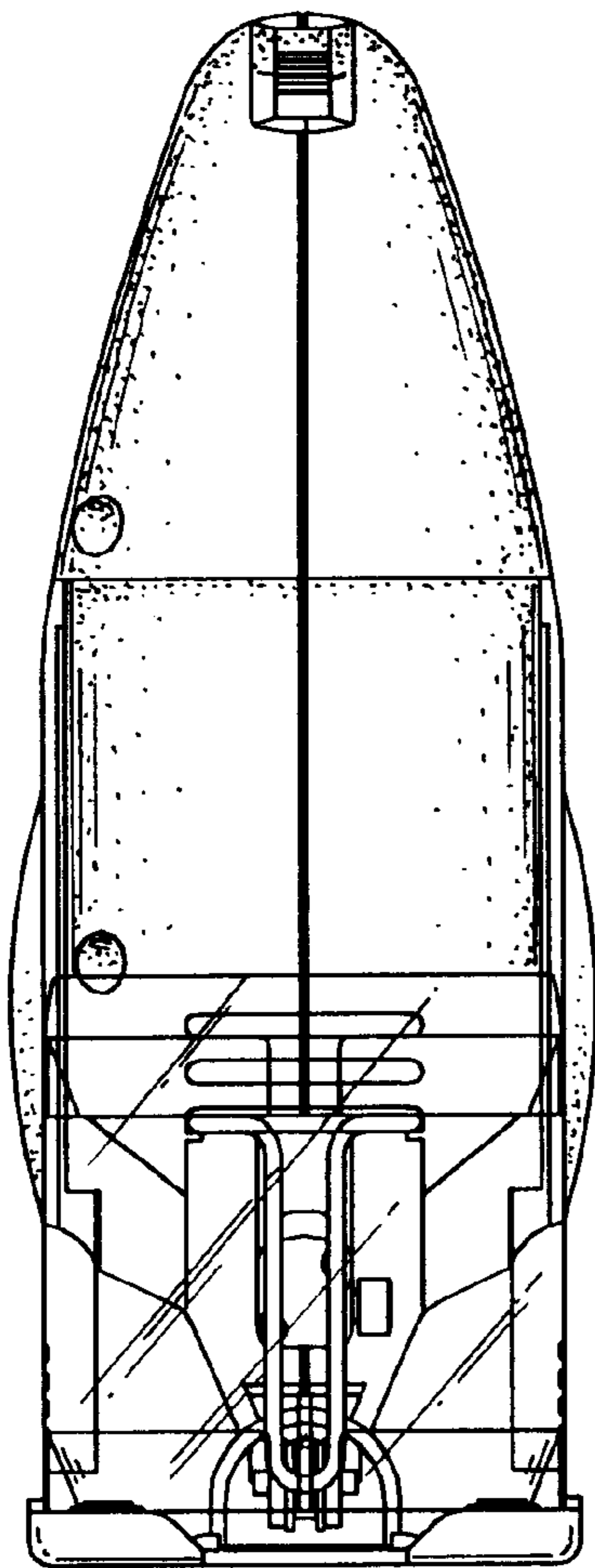
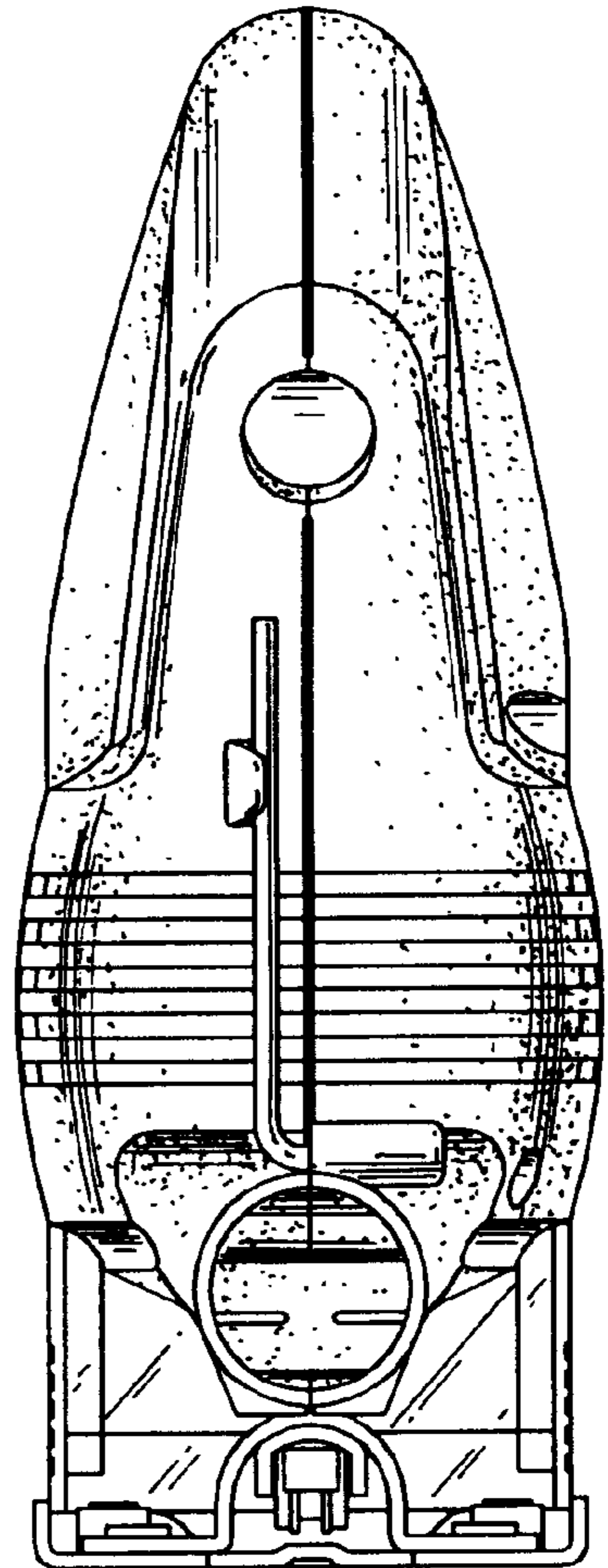
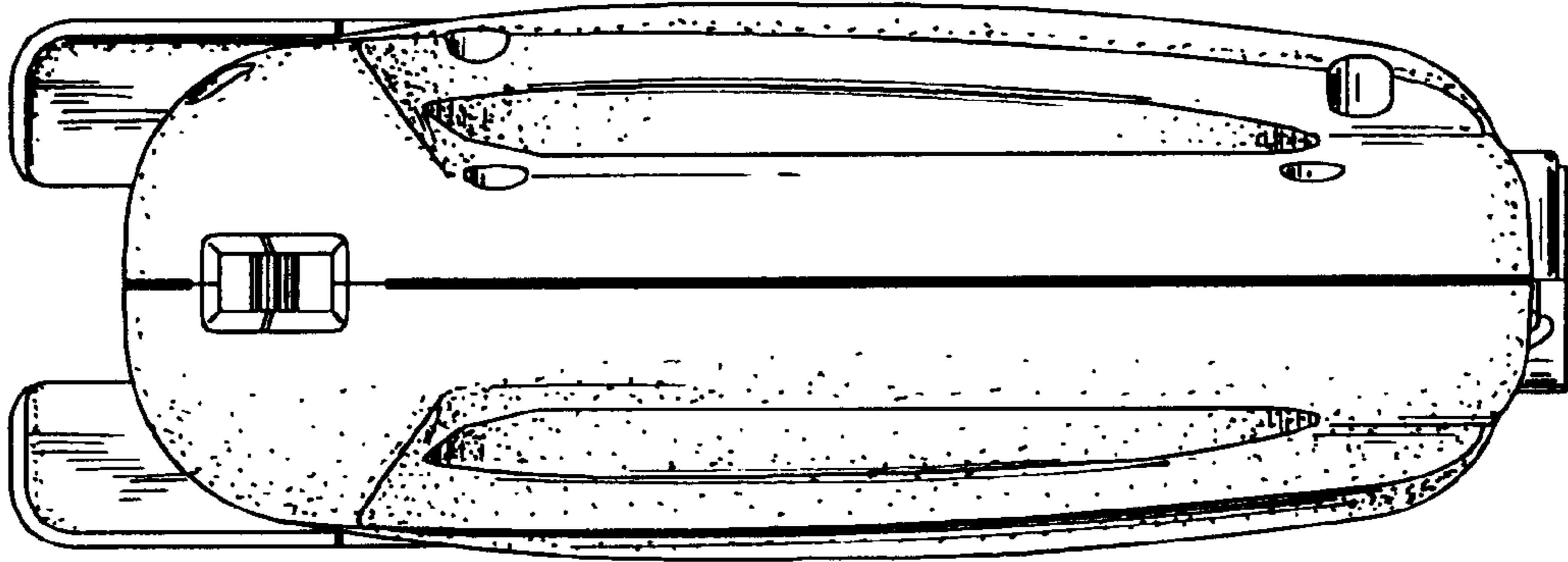

FIG. 5



# FIG. 6



# FIG. 7

