



US00D409438S

United States Patent [19]
Brady

[11] **Patent Number: Des. 409,438**

[45] **Date of Patent: ** May 11, 1999**

[54] **PAIR OF TOASTER END PANELS**

[75] Inventor: **Martin Brady**, Chesterfield, Va.

[73] Assignee: **Hamilton Beach/Proctor-Silex, Inc.**,
Glen Allen, Va.

[**] Term: **14 Years**

[21] Appl. No.: **29/071,016**

[22] Filed: **May 15, 1997**

[51] **LOC (6) Cl.** **07-02**

[52] **U.S. Cl.** **D7/390; D7/330**

[58] **Field of Search** **D7/323, 328-330,**
D7/390; 99/327, 341, 372, 385, 389, 391,
392

[56] **References Cited**

U.S. PATENT DOCUMENTS

D. 177,033	3/1956	Guild	D7/330
D. 201,736	7/1965	Peterson	D7/330
D. 203,527	1/1966	Peterson	D7/330
D. 258,926	4/1981	Hentschel	D7/330
D. 328,833	8/1992	Myers et al.	D7/330

OTHER PUBLICATIONS

Commonly-owned design patent application serial No. 29/071,017, originally filed May 15, 1997, refiled as continued prosecution application on Mar. 18, 1998.

Information concerning prior offers for sale described in Supplemental Information Disclosure Statement filed herewith.

Primary Examiner—Caron D. Veynar

Attorney, Agent, or Firm—Roger S. Dybvig

[57] **CLAIM**

The ornamental design for a pair of toaster end panels, as shown and described.

DESCRIPTION

FIG. 1 is a perspective view as seen from the top, front and left side of a pair of toaster end panels showing my new design;

FIG. 2 is a perspective view as seen from the top, rear, and right side of the pair of toaster end panels shown in FIG. 1.

FIG. 3 is a top plan view thereof;

FIG. 4 is a bottom plan view thereof;

FIG. 5 is a left side elevational view thereof;

FIG. 6 is a right side elevational view thereof;

FIG. 7 is a front elevational view thereof showing only a front toaster end panel, it being understood that the opposite face of the front toaster end panel is not visible during normal use; and,

FIG. 8 is a rear elevational view thereof showing only a rear toaster end panel, it being understood that the opposite face of the rear toaster end panel is not visible during normal use.

FIG. 9 is a front elevational view showing a second embodiment of a front toaster end panel in accordance with this invention. The front toaster end panel shown in FIG. 9 differs from the front toaster end panel shown in FIGS. 1 through 7 only in the addition of vent slots; and

FIG. 10 is a rear elevational view showing a second embodiment of a rear toaster end panel in accordance with this invention. The rear toaster end panel shown in FIG. 10 differs from the rear toaster end panel shown in FIGS. 1 through 6 and 8 only in the addition of vent slots. It will be understood that the second embodiment of a front toaster end panel shown in FIG. 9 and the second embodiment of a rear toaster end panel shown in FIG. 10 together form a second embodiment of a pair of toaster end panels in accordance with this invention.

FIG. 11 is a perspective view as seen from the top, front and left side of a third embodiment of my design for a pair of toaster end panels;

FIG. 12 is a perspective view as seen from the top, rear, and right side of third embodiment of a pair of toaster end panels shown in FIG. 11.

FIG. 13 is a top plan view thereof;

FIG. 14 is a bottom plan view thereof;

FIG. 15 is a left side elevational view thereof;

FIG. 16 is a right side elevational view thereof;

FIG. 17 is a front elevational view thereof showing only a front toaster end panel of the pair of toaster end panels shown in FIGS. 11 through 16, it being understood that the opposite face of the front toaster end panel is not visible during normal use, the front toaster end panel shown in FIG. 17 being a third embodiment of a front toaster end panel in accordance with this invention; and

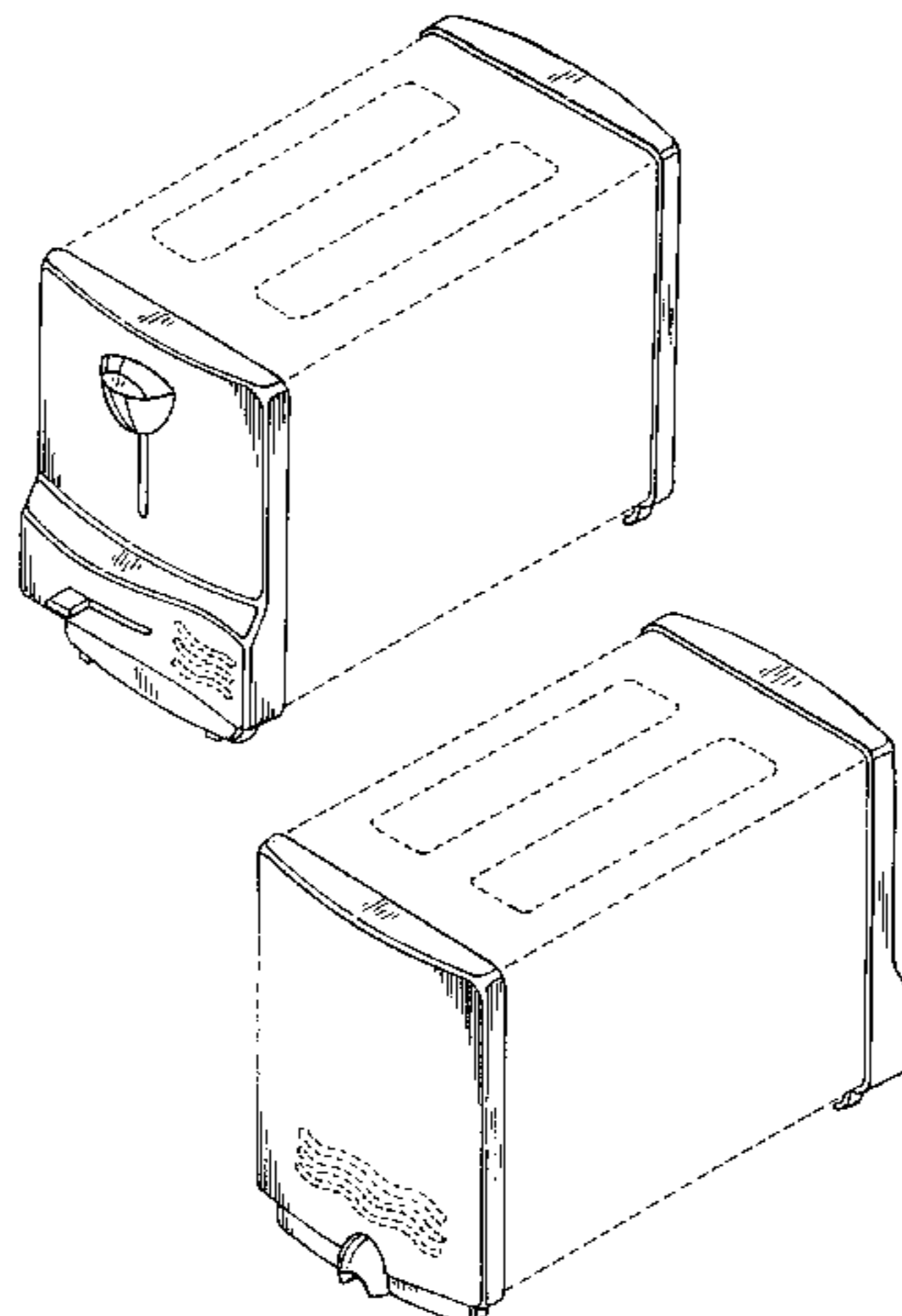

FIG. 18 is a rear elevational view thereof showing only a rear toaster end panel of the pair of toaster end panels shown in FIGS. 11 through 16, it being understood that the opposite face of the rear toaster end panel is not visible during normal use, the rear toaster end panel shown in FIG. 18 being a third embodiment of a rear toaster end panel in accordance with this invention.

FIG. 19 is a front elevational view showing a fourth embodiment of a front toaster end panel in accordance with this invention. The front toaster end panel shown in FIG. 19 differs from the front toaster end panel shown in FIGS. 11 through 17 only in the addition of vent slots; and,

FIG. 20 is a rear elevational view showing a fourth embodiment of a rear toaster end panel in accordance with this invention. The rear toaster end panel shown in FIG. 20 differs from the rear toaster end panel shown in FIGS. 11 through 16 and 18 only in the addition of vent slots. It will be understood that the fourth embodiment of a front toaster end panel shown in FIG. 19 and the fourth embodiment of a rear toaster end panel shown in FIG. 20 together form a fourth embodiment of a pair of toaster end panels in accordance with this invention.

The broken lines in FIGS. 1 through 6 and 11 through 16 showing a toaster housing separating the pair of toaster end panels, in FIGS. 1 through 3 and 11 through 13 showing toast slots, in FIGS. 1, 2, 7, 8, 11, 12, 17, and 18 showing vent slots, in FIGS. 11, 13 through 17, and 19 showing a toast carriage handle and a toaster color control lever, and in FIGS. 11, 17, and 19 showing a toast carriage handle slot are used for illustrative purposes only and form no part of the claimed design.

1 Claim, 4 Drawing Sheets

FIG-1

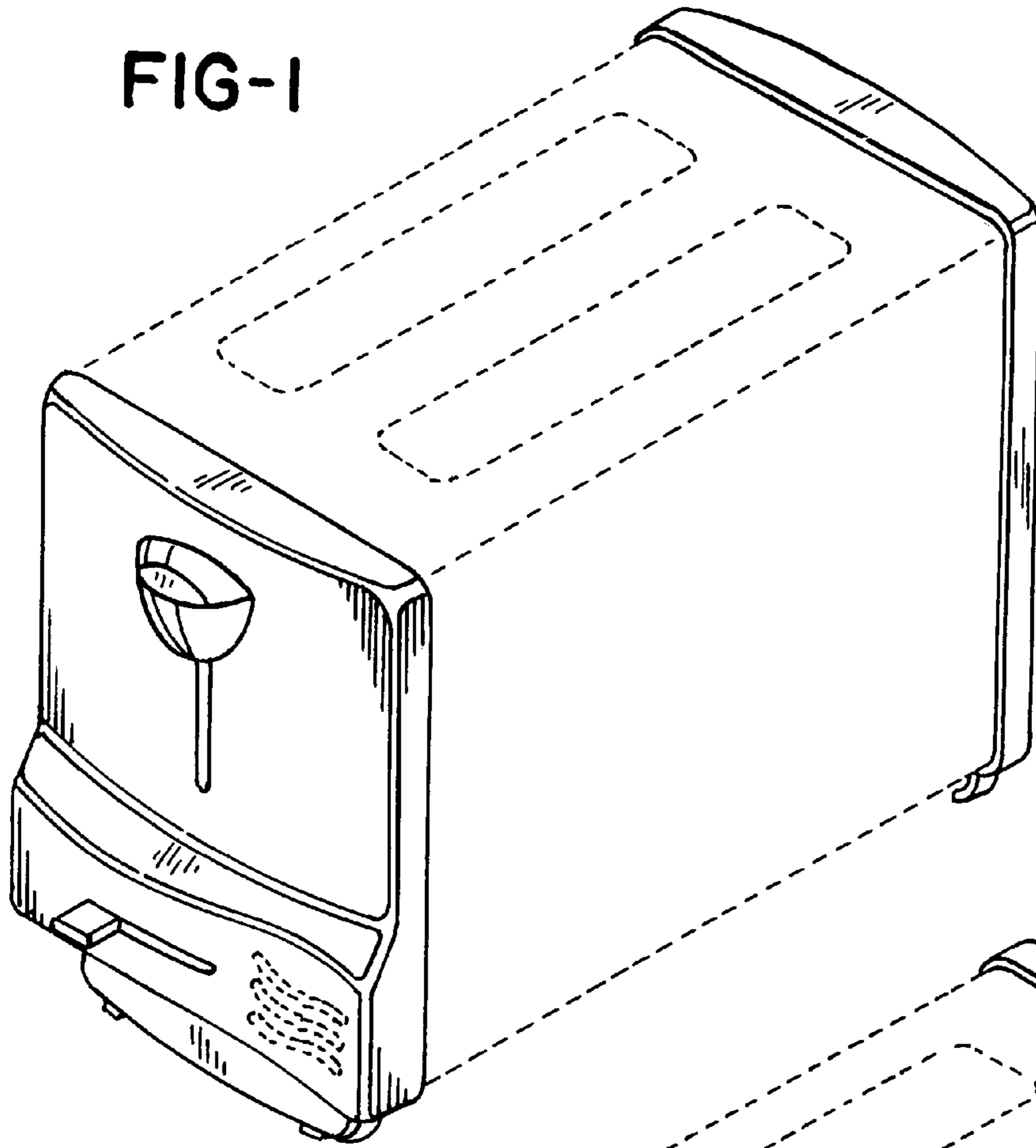

FIG-2

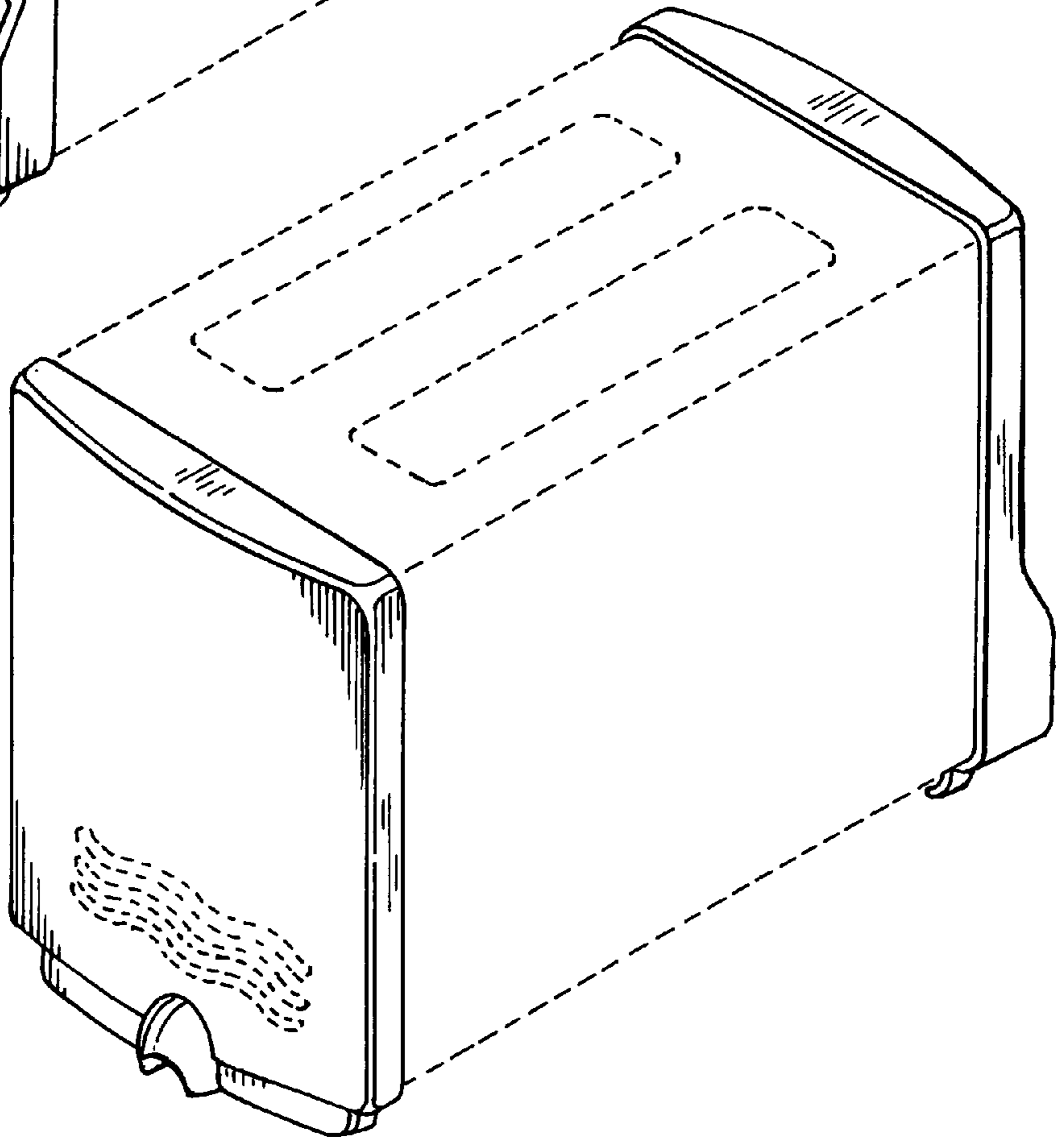

FIG-3

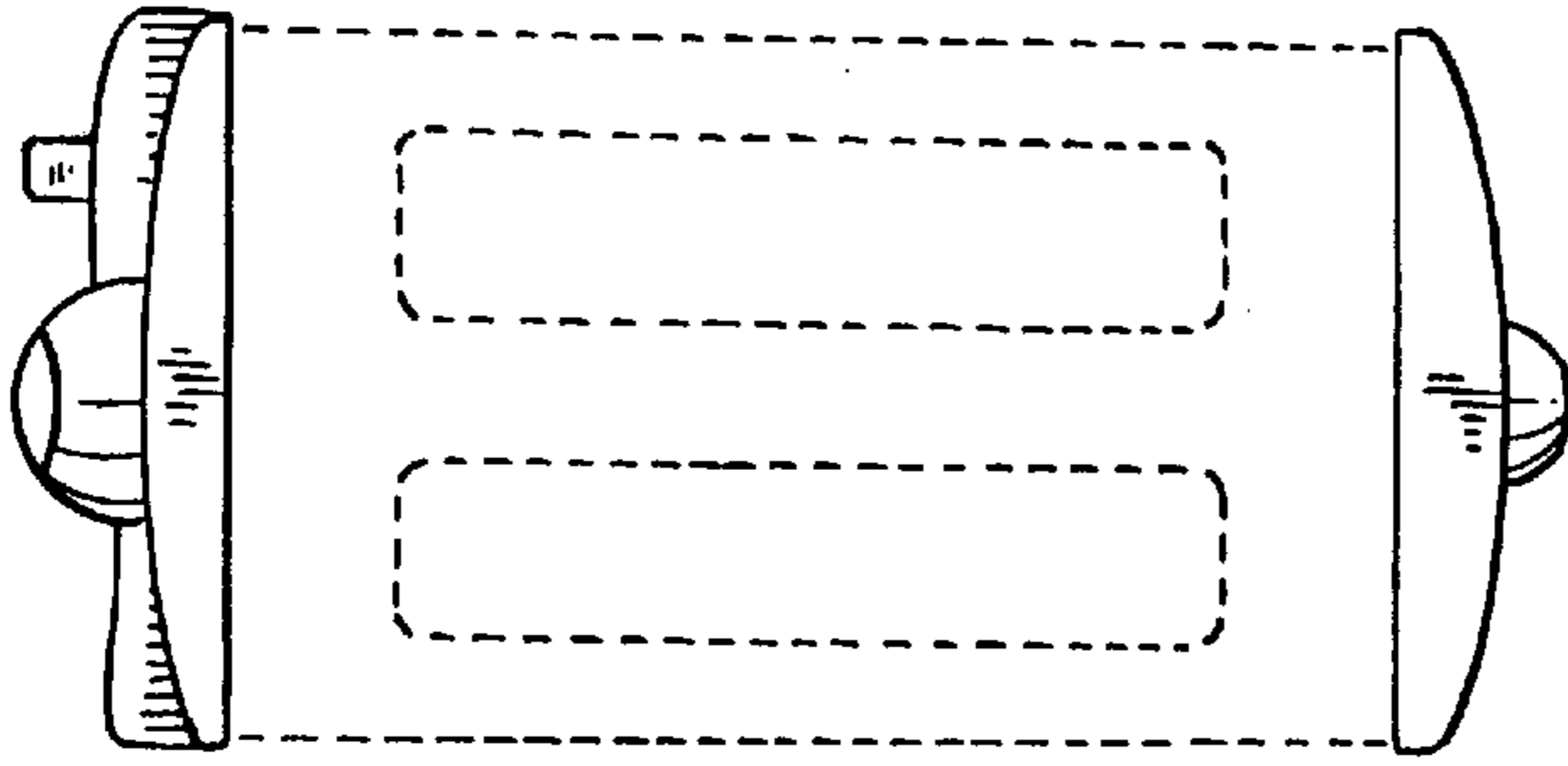

FIG-4



FIG-5

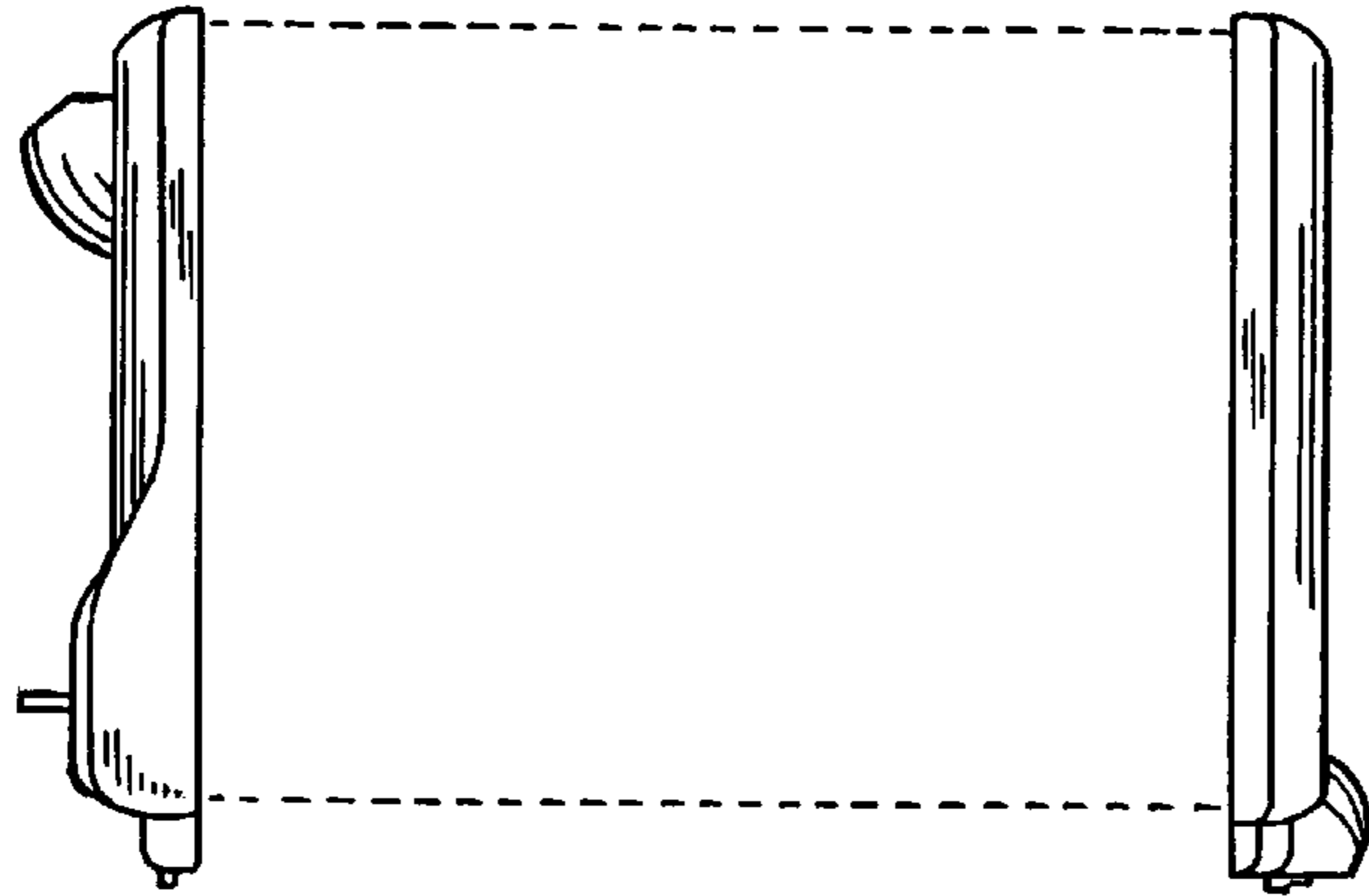

FIG-6

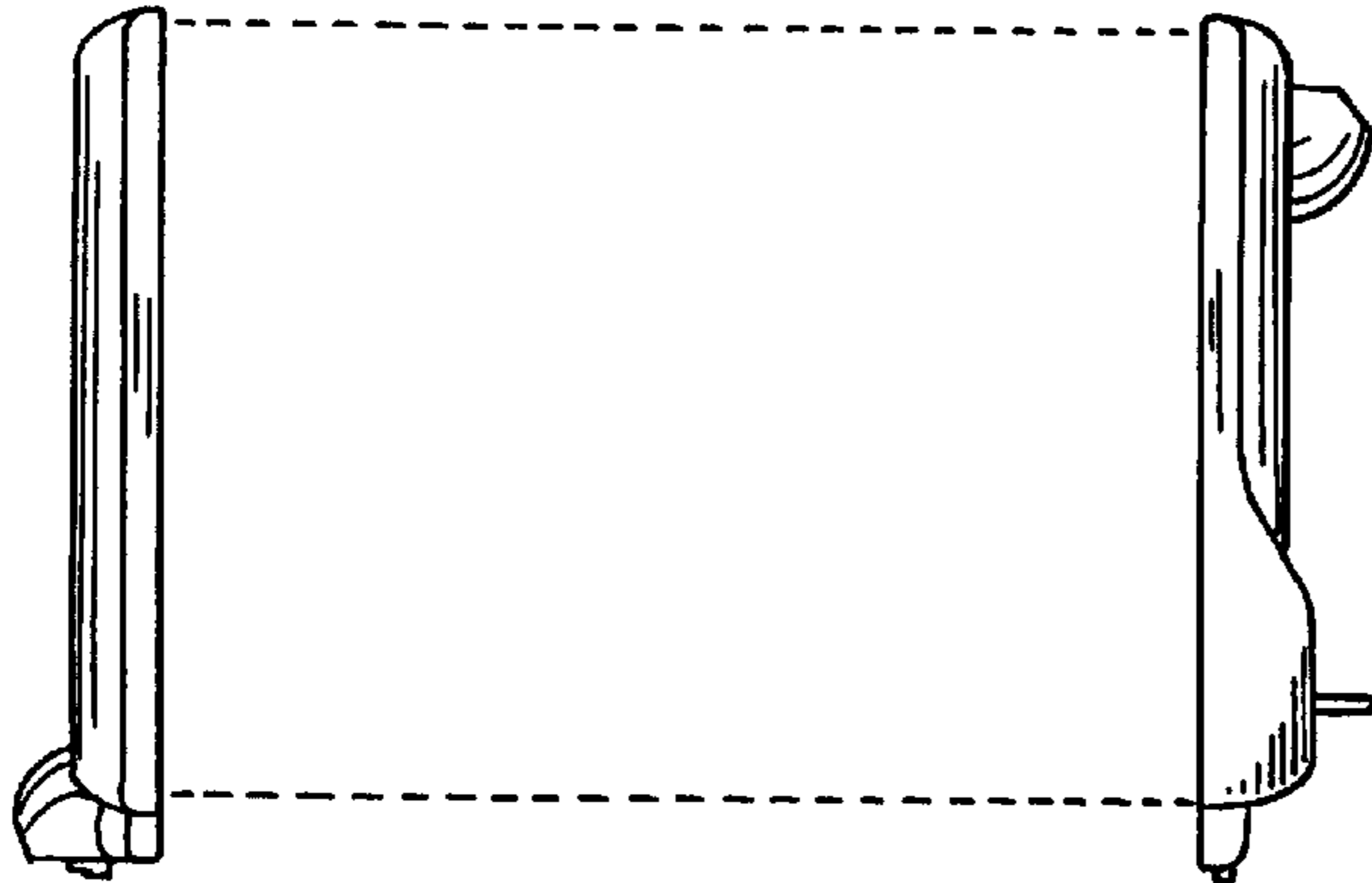

FIG-7

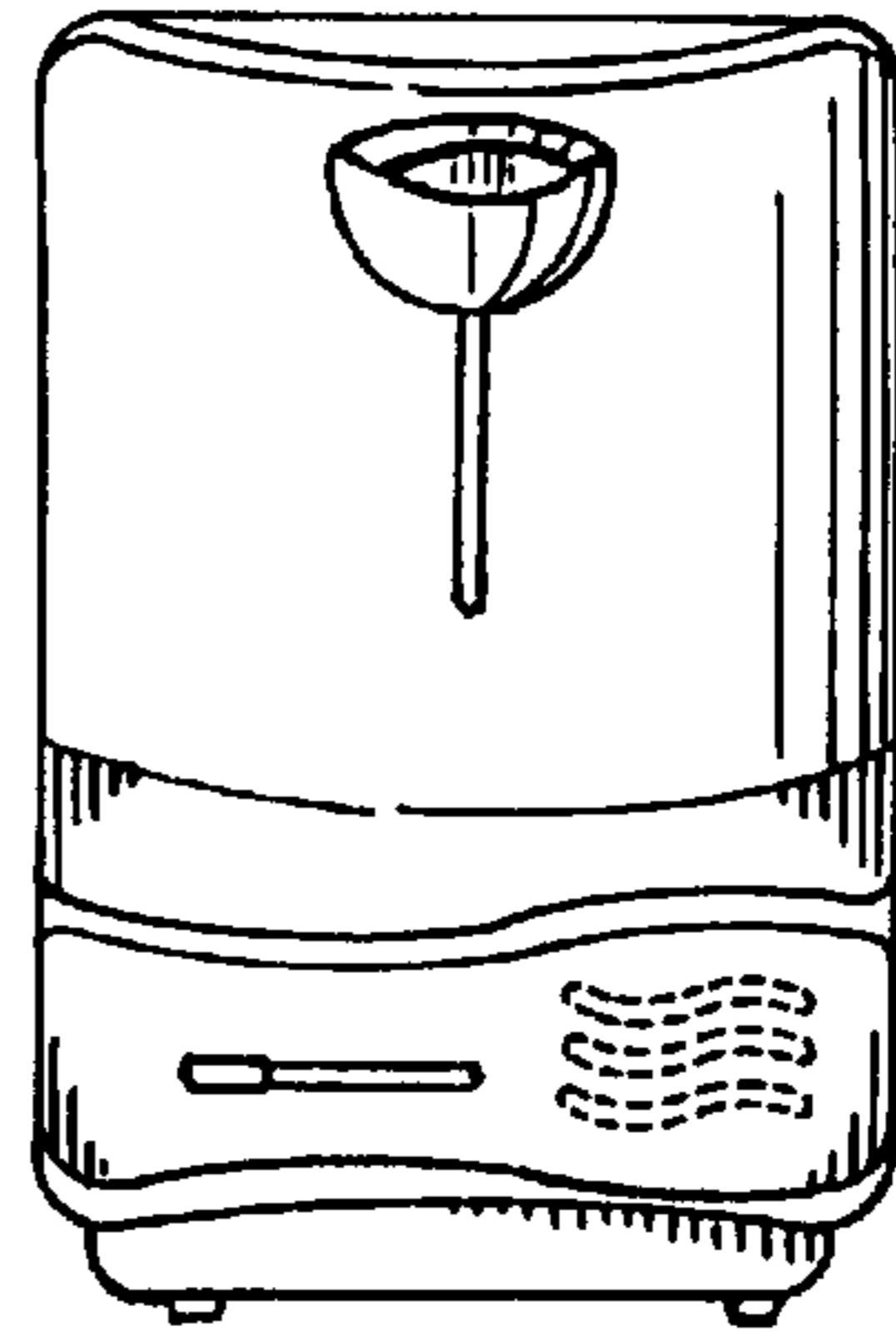

FIG-8

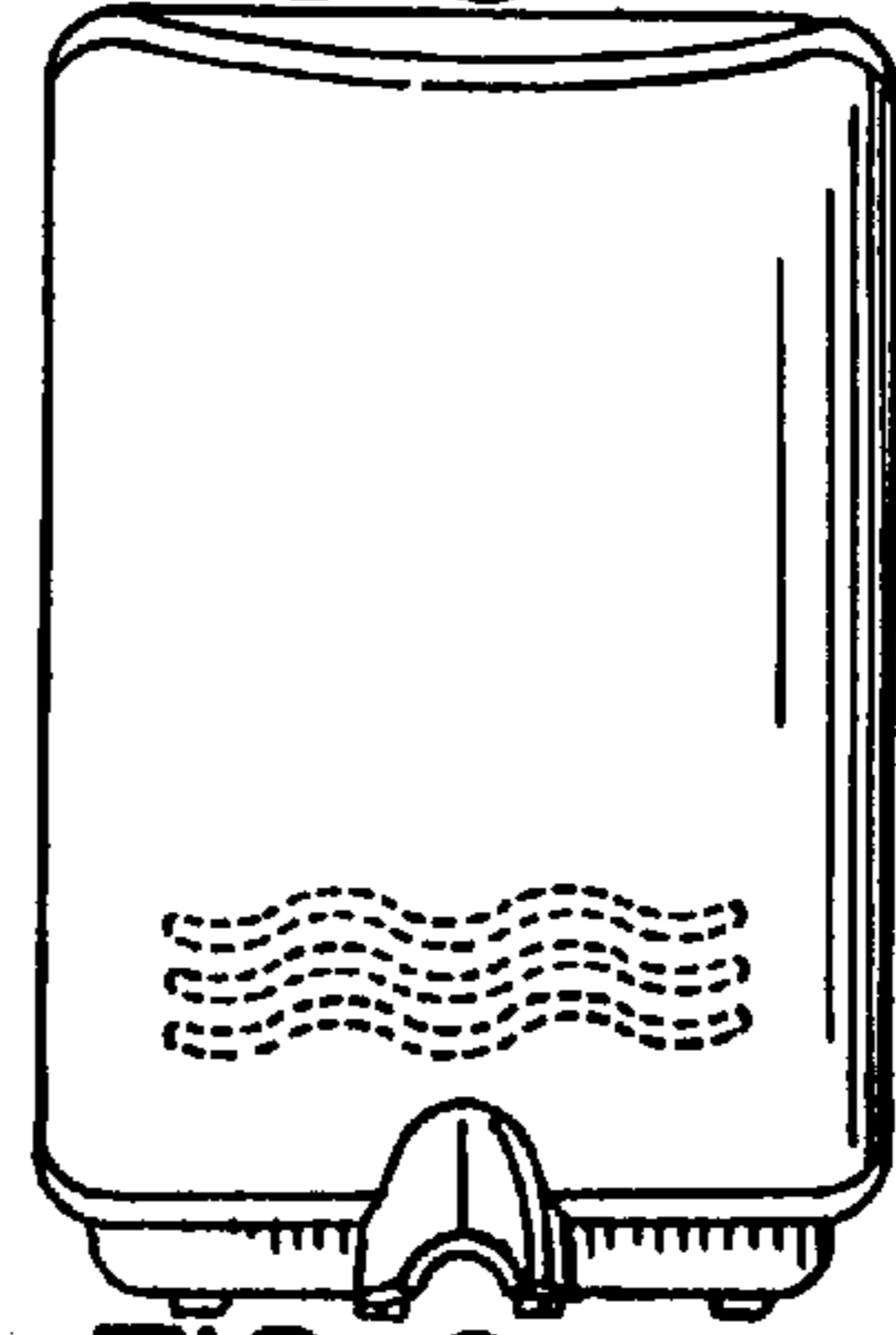

FIG-9

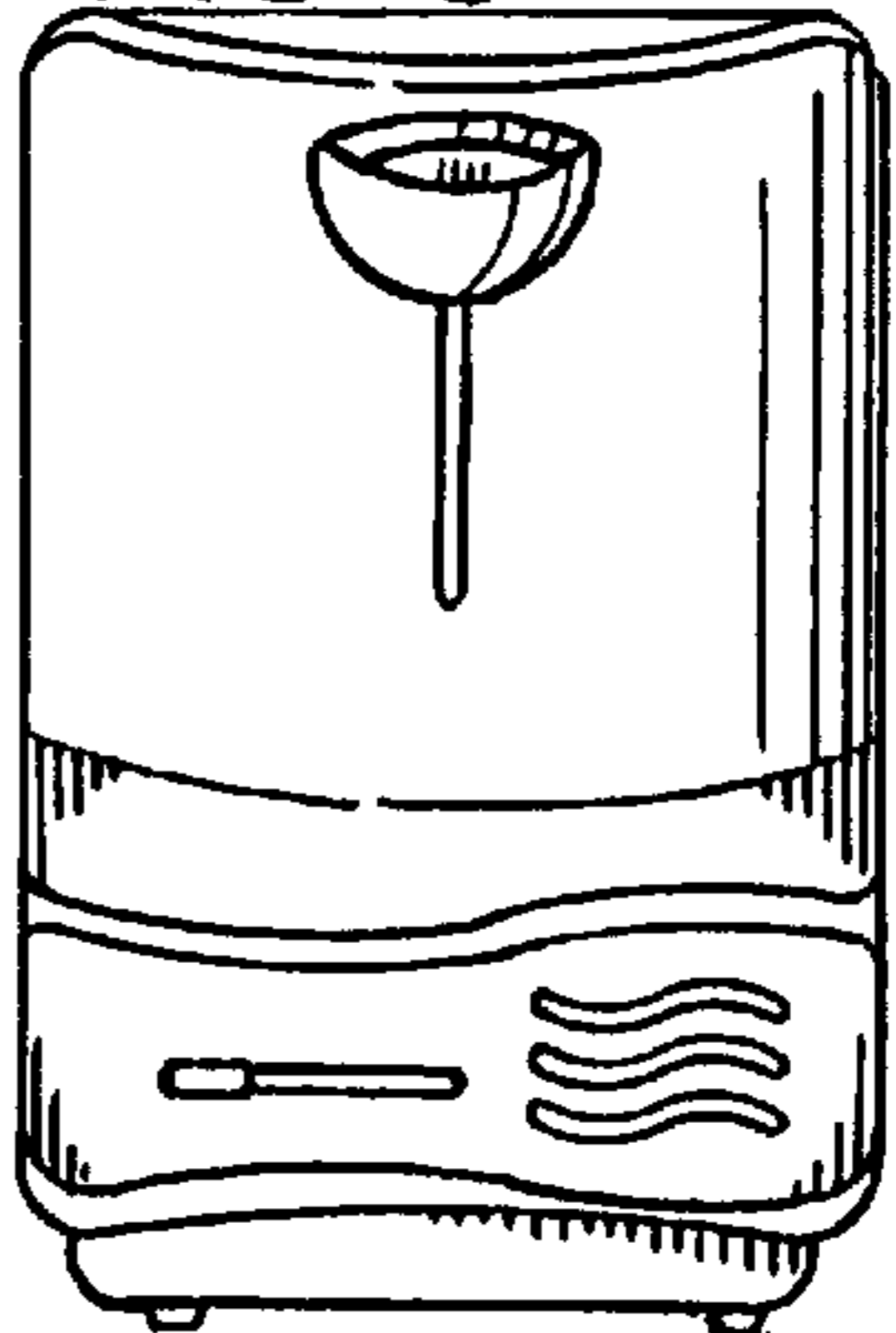

FIG-10

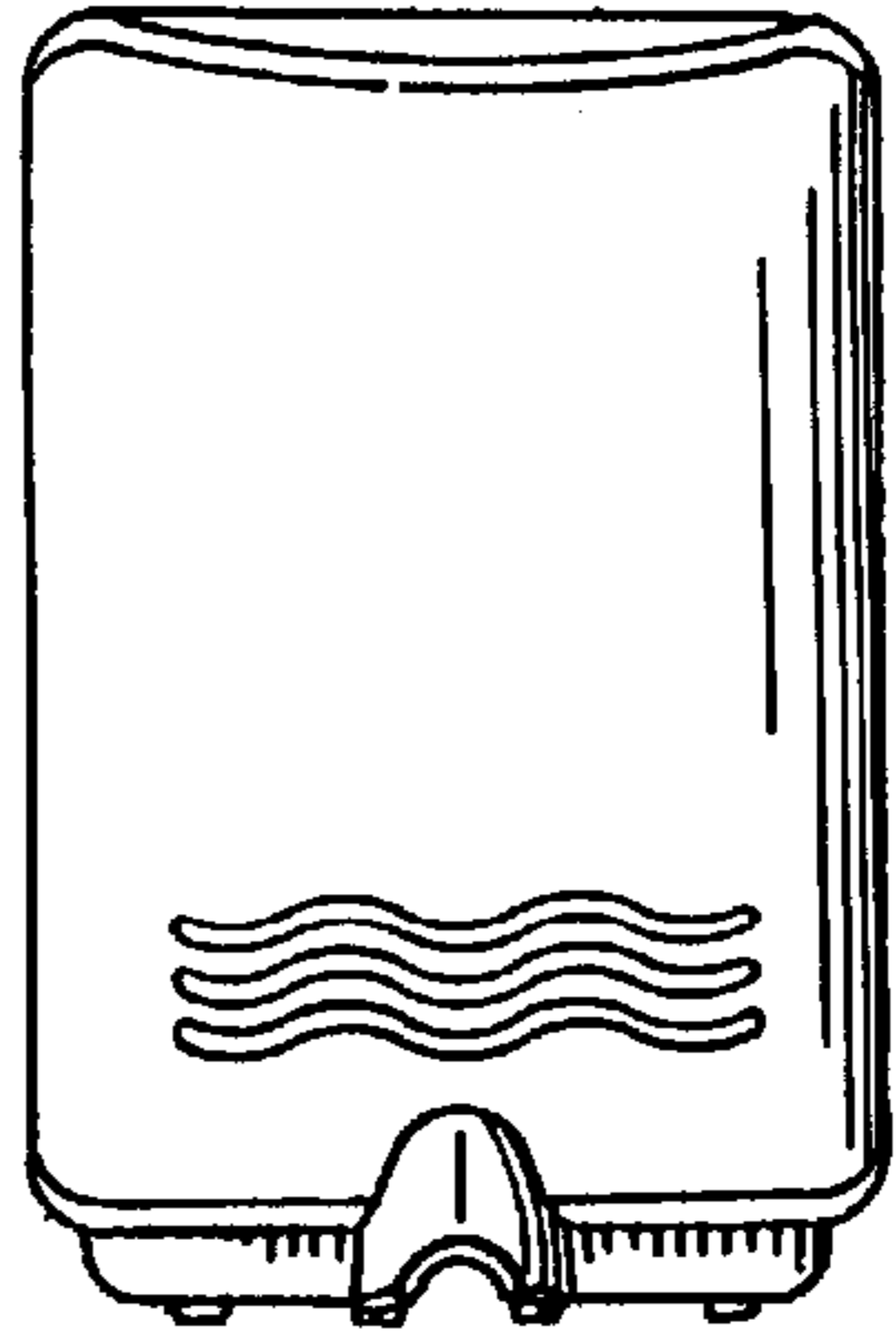

FIG-11

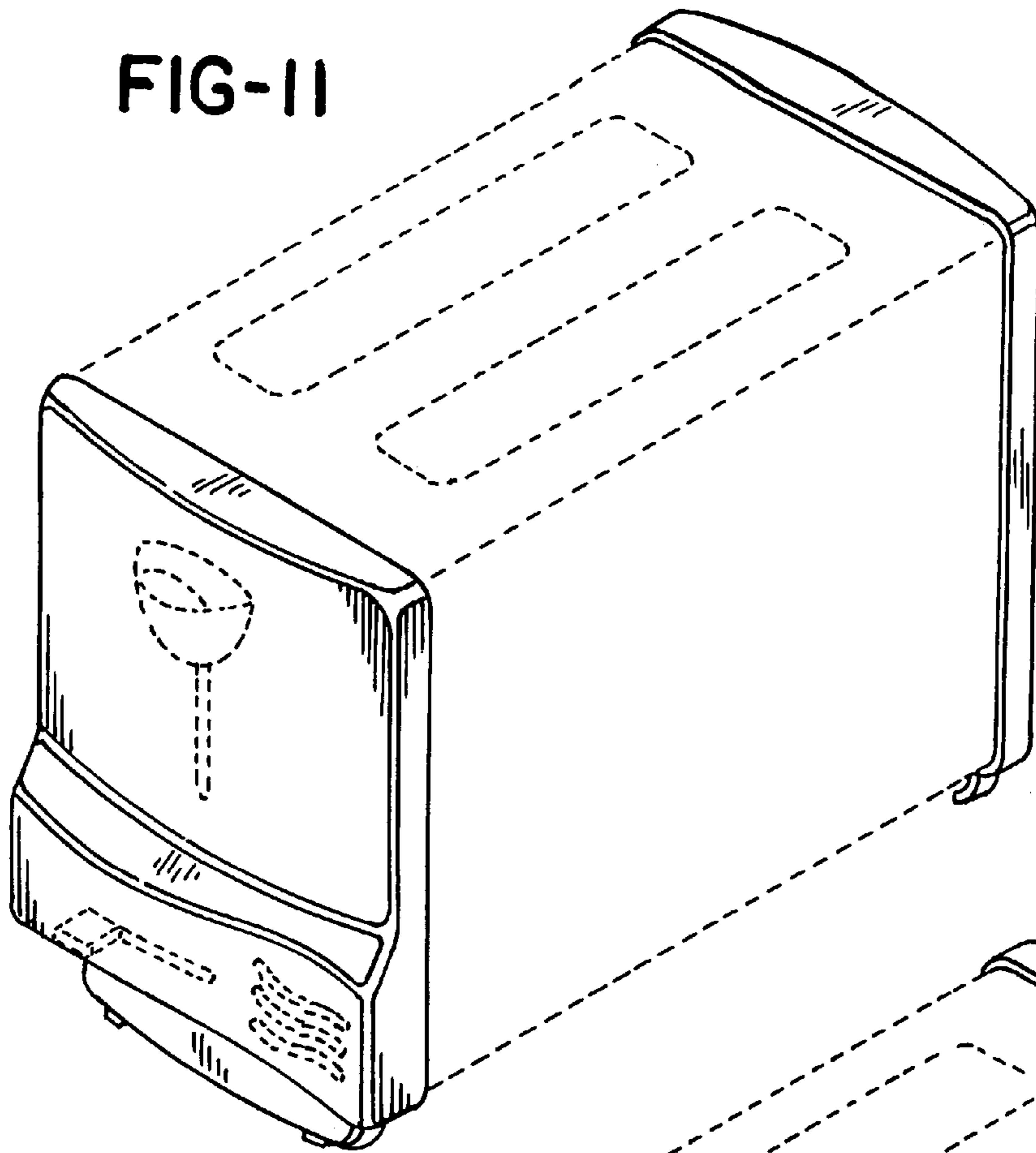

FIG-12

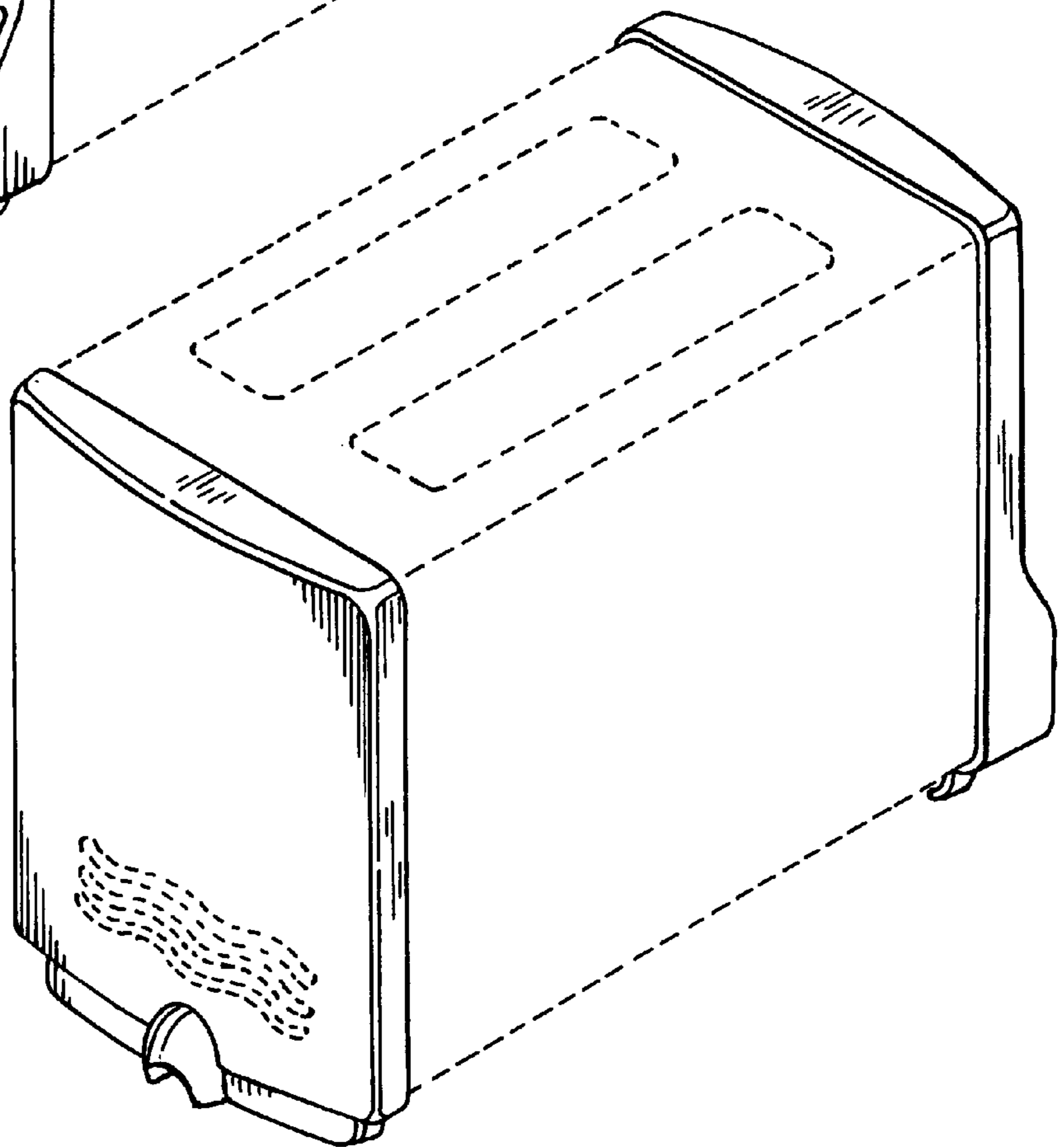

FIG-13

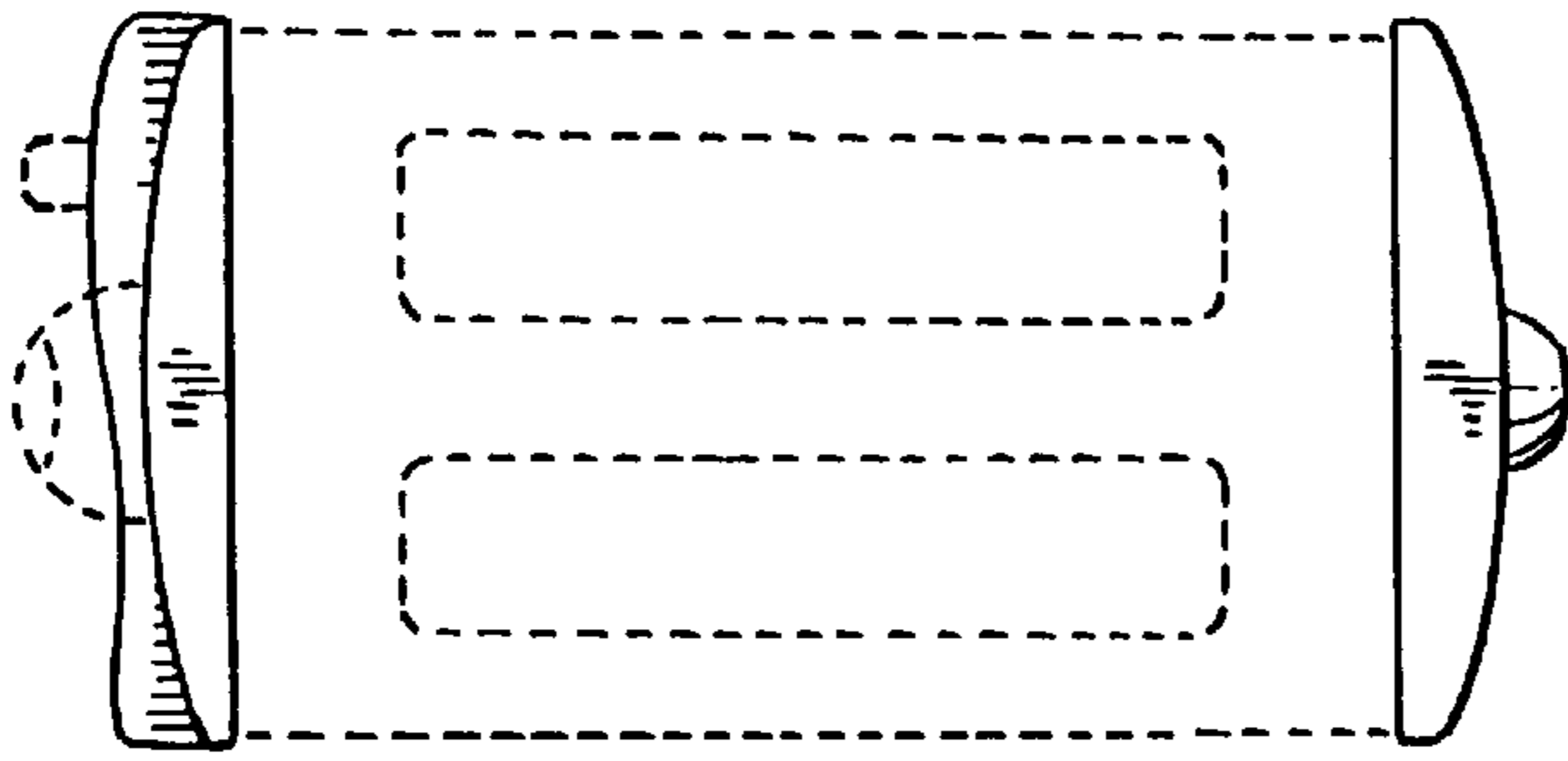

FIG-14



FIG-15

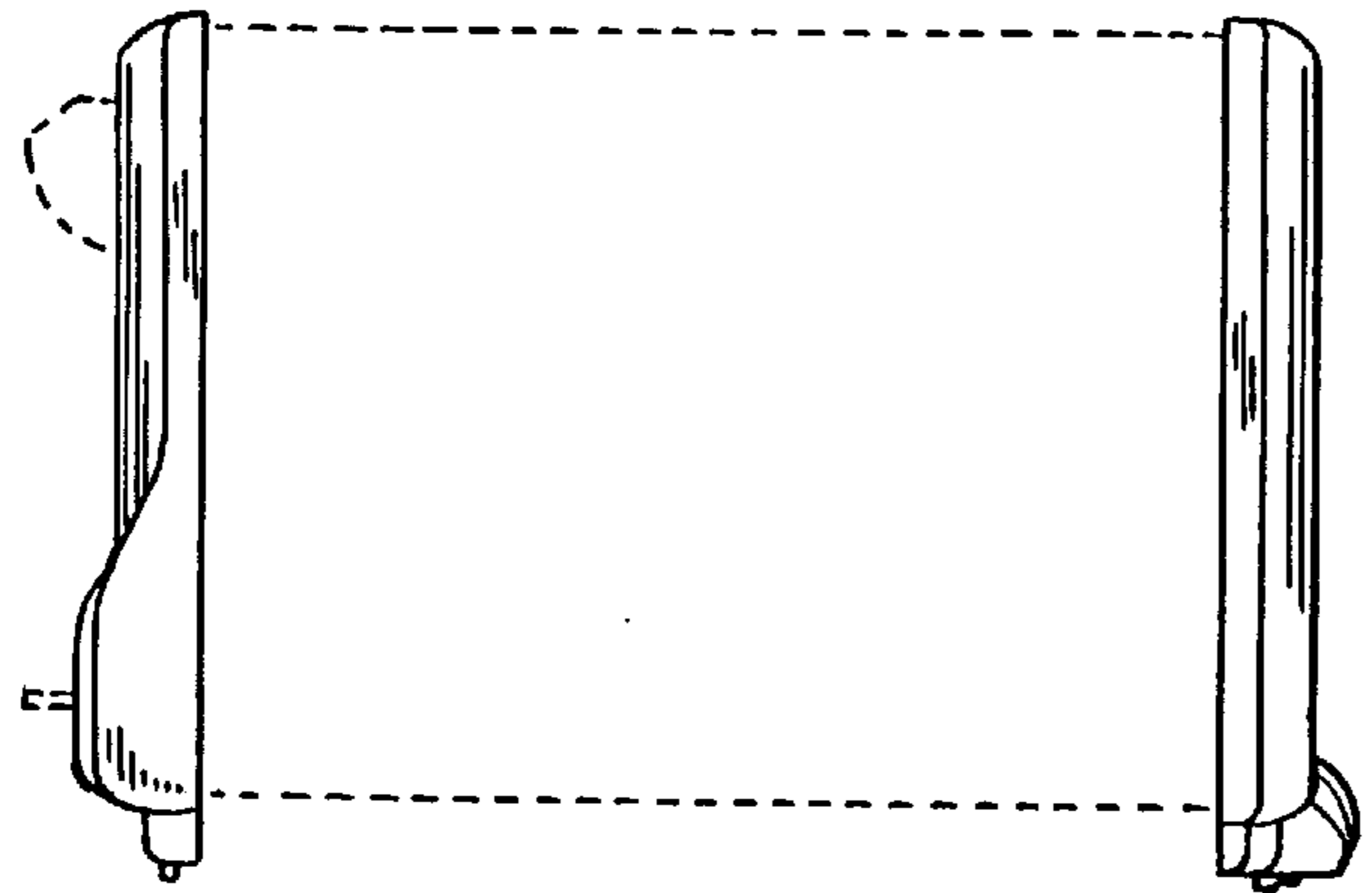

FIG-16

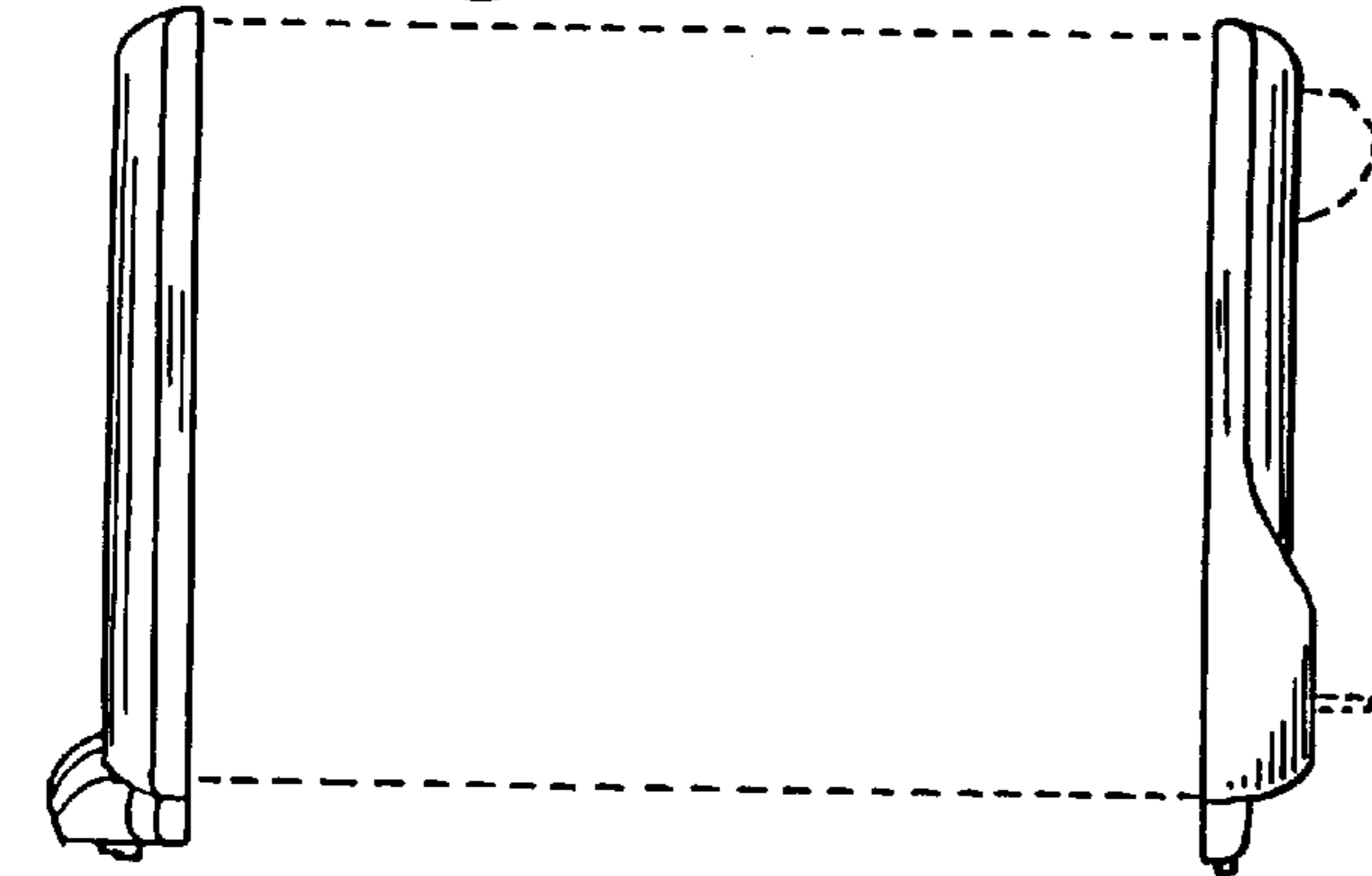

FIG-17

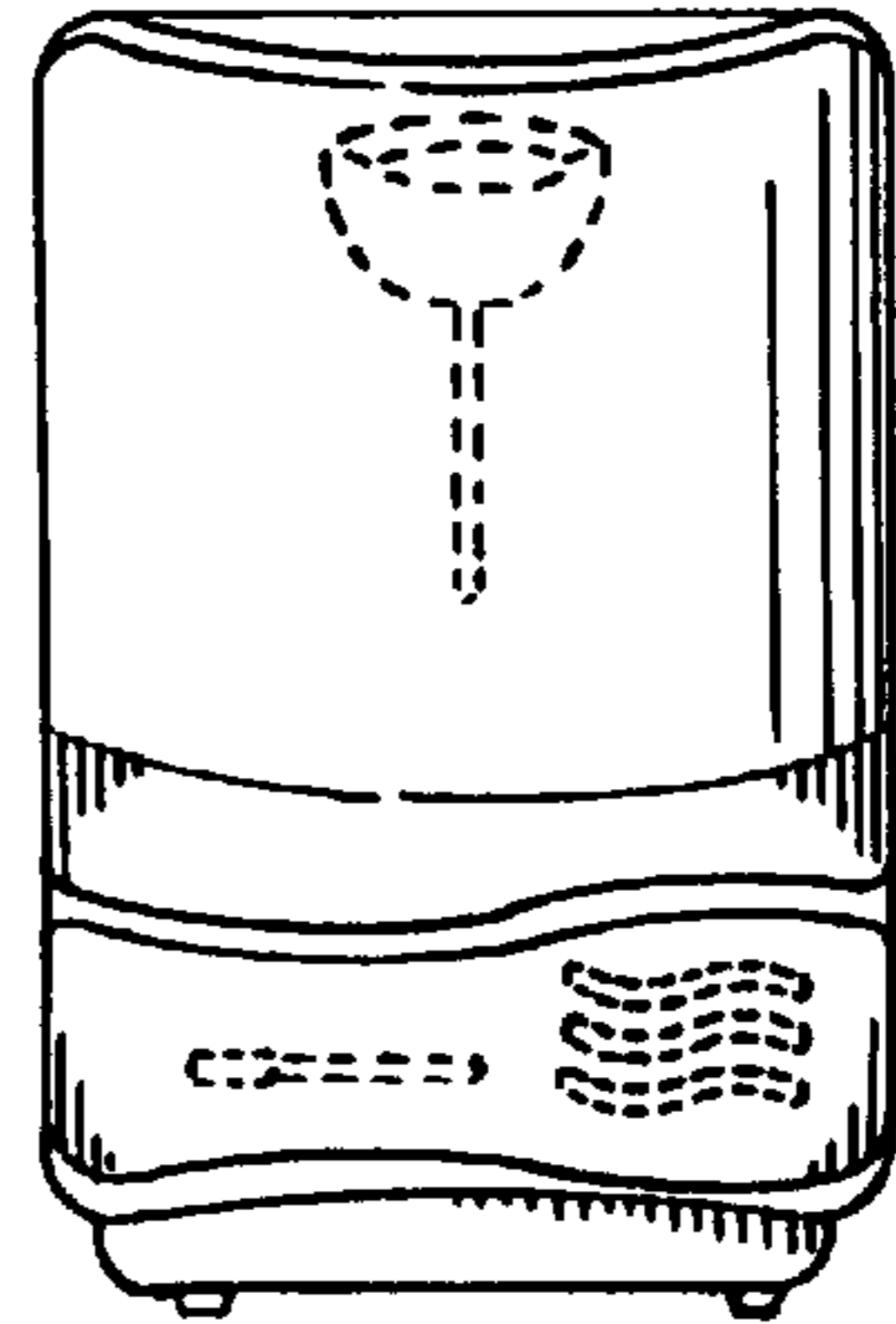

FIG-18

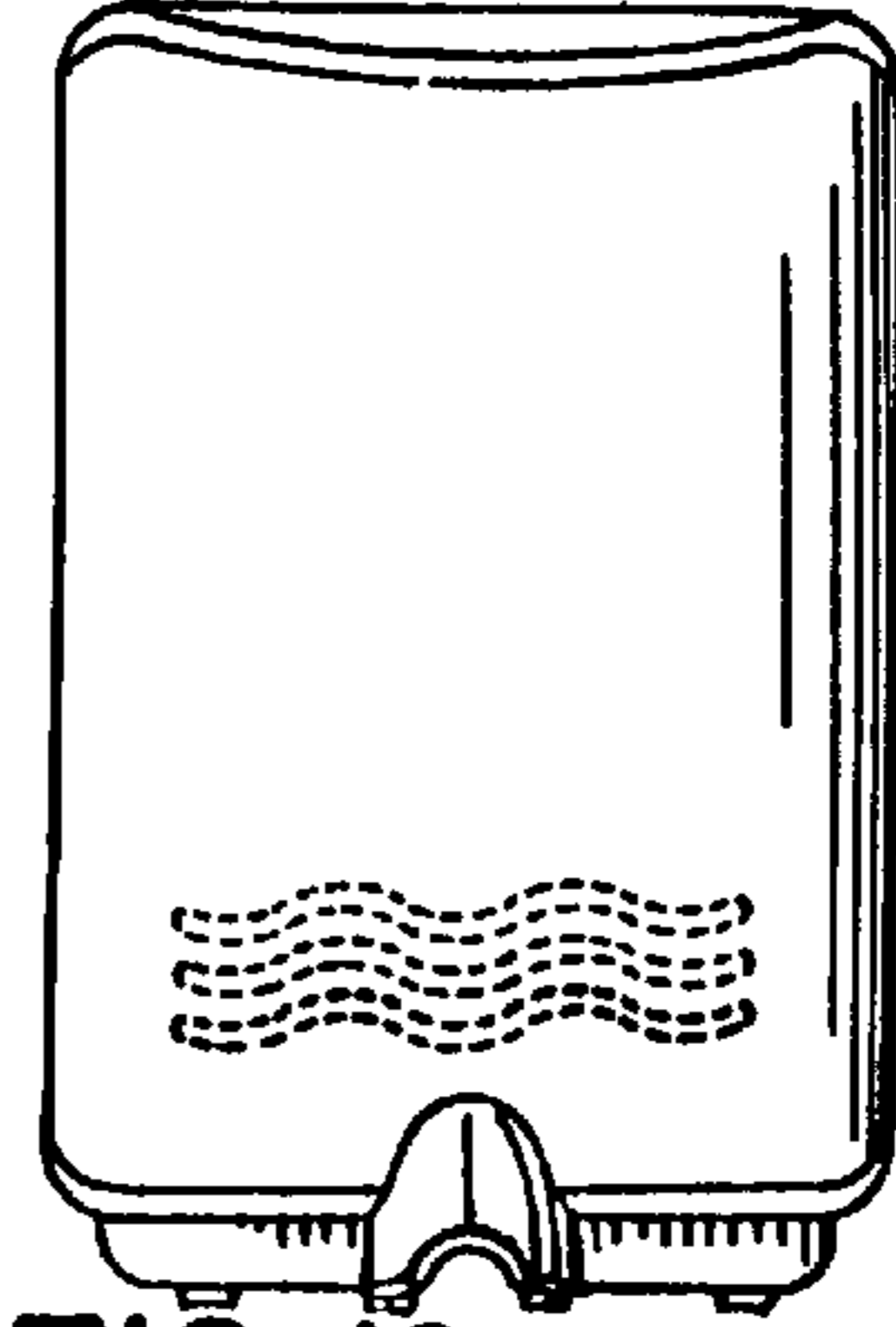

FIG-19

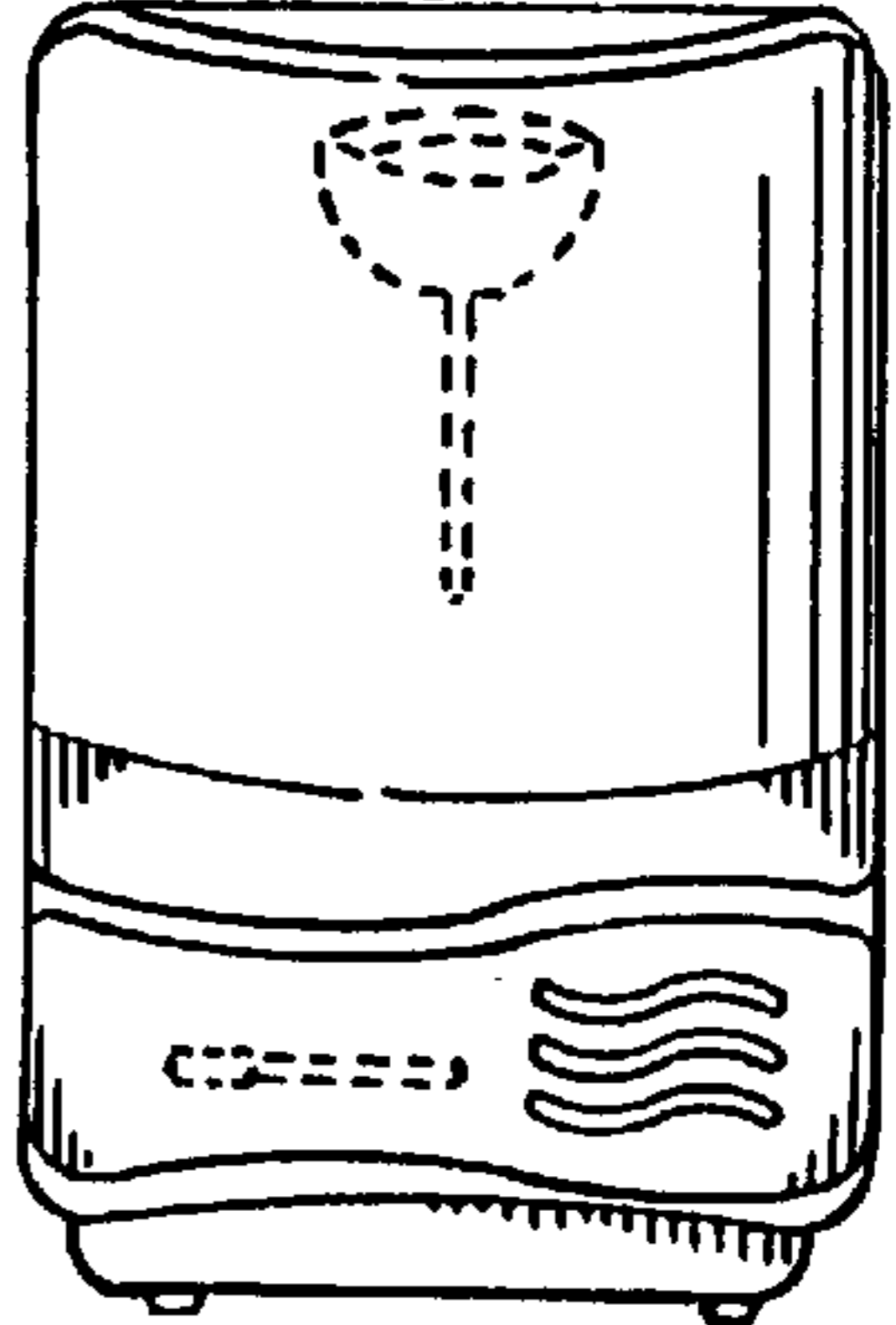

FIG-20

