



US00D409296S

# United States Patent [19]

Kerlin et al.

[11] **Patent Number: Des. 409,296**

[45] **Date of Patent: \*\* May 4, 1999**

[54] **AIR DUCT FOR A GOLF CAR**

5,052,283 10/1991 Altus .

[75] Inventors: **James R. Kerlin**, Evans; **Donald G. Samuelson**, Augusta, both of Ga.;  
**David N. Schult**, North Augusta, S.C.

*Primary Examiner*—Lisa Lichtenstein  
*Attorney, Agent, or Firm*—John J. Selko

[73] Assignee: **Club Car, Inc.**, Augusta, Ga.

[\*\*] Term: **14 Years**

[57] **CLAIM**

The ornamental design for an air duct for a golf car, as shown.

[21] Appl. No.: **29/075,137**

[22] Filed: **Aug. 12, 1997**

**DESCRIPTION**

[51] **LOC (6) Cl.** ..... **12-16**

[52] **U.S. Cl.** ..... **D23/324**

[58] **Field of Search** ..... D23/324, 386,  
D23/393; 454/144

FIG. 1 is a top, rear and side pictorial view of the air duct of the invention;

FIG. 2 is a top plan view of the design;

FIG. 3 is a right side view of the design;

FIG. 4 is a bottom plan view of the design;

FIG. 5 is a left side view of the design;

FIG. 6 is a front view of the design;

FIG. 7 is a rear view of the design; and,

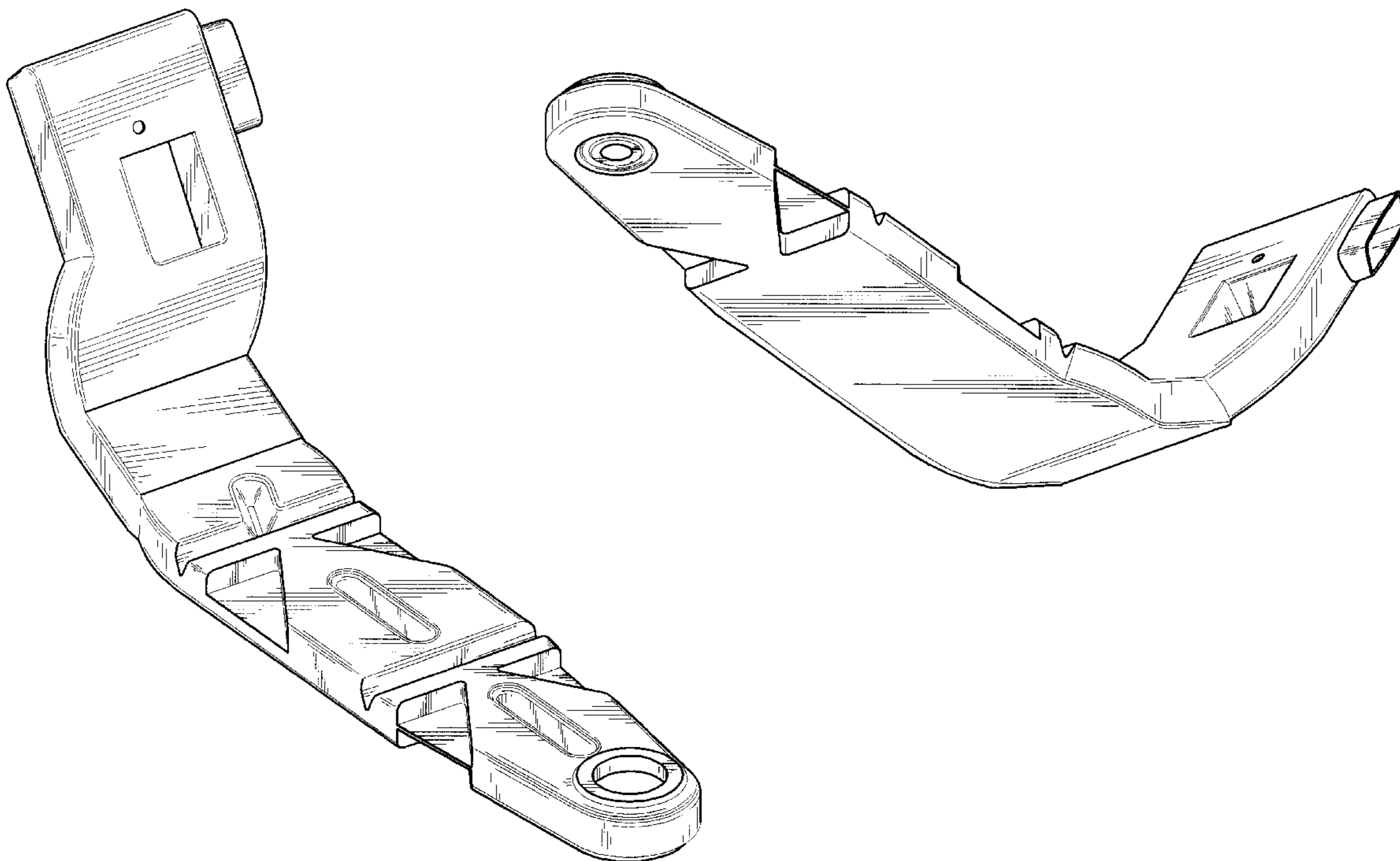
FIG. 8 is a bottom, rear and side pictorial view of the design.

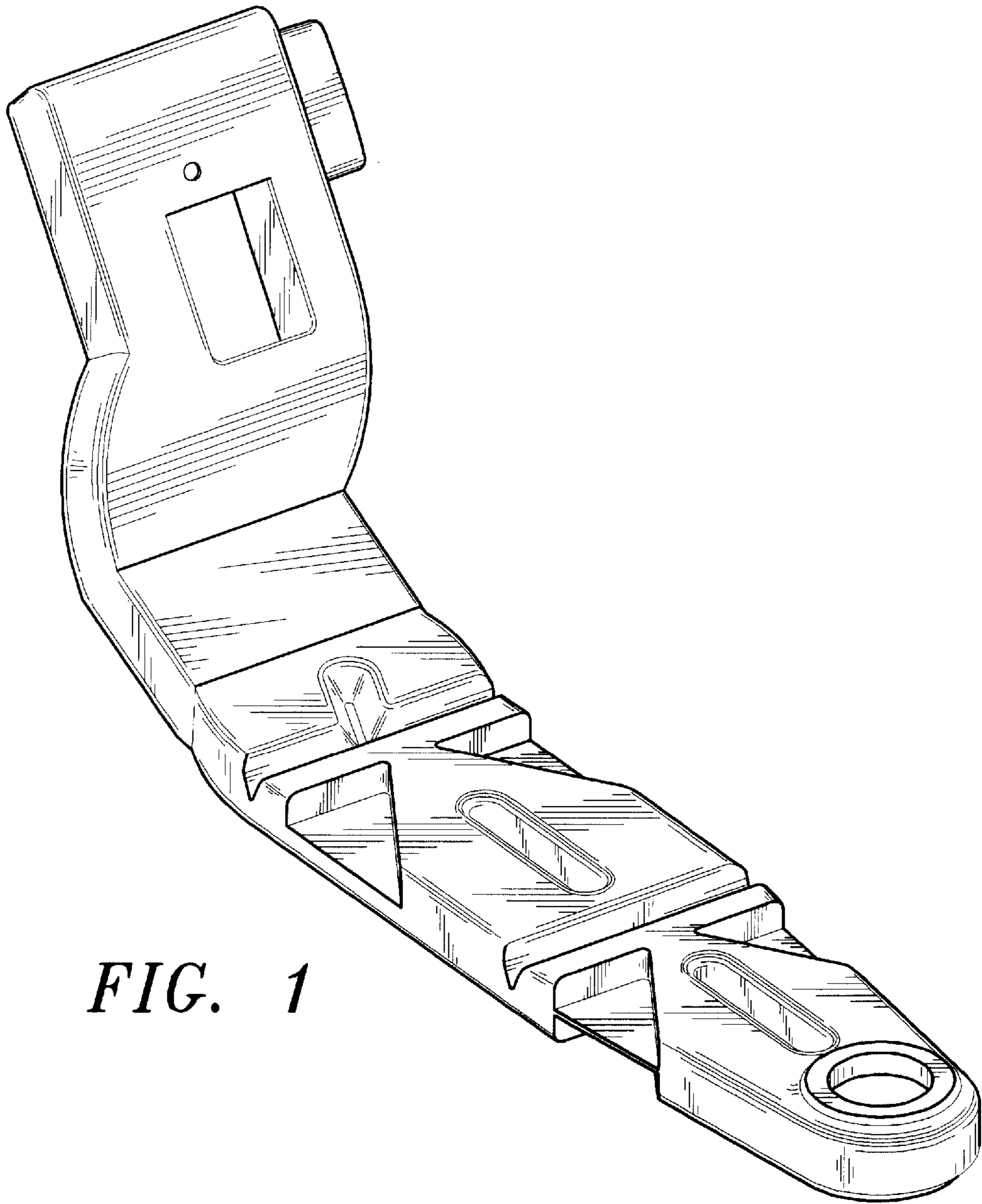
[56] **References Cited**

**U.S. PATENT DOCUMENTS**

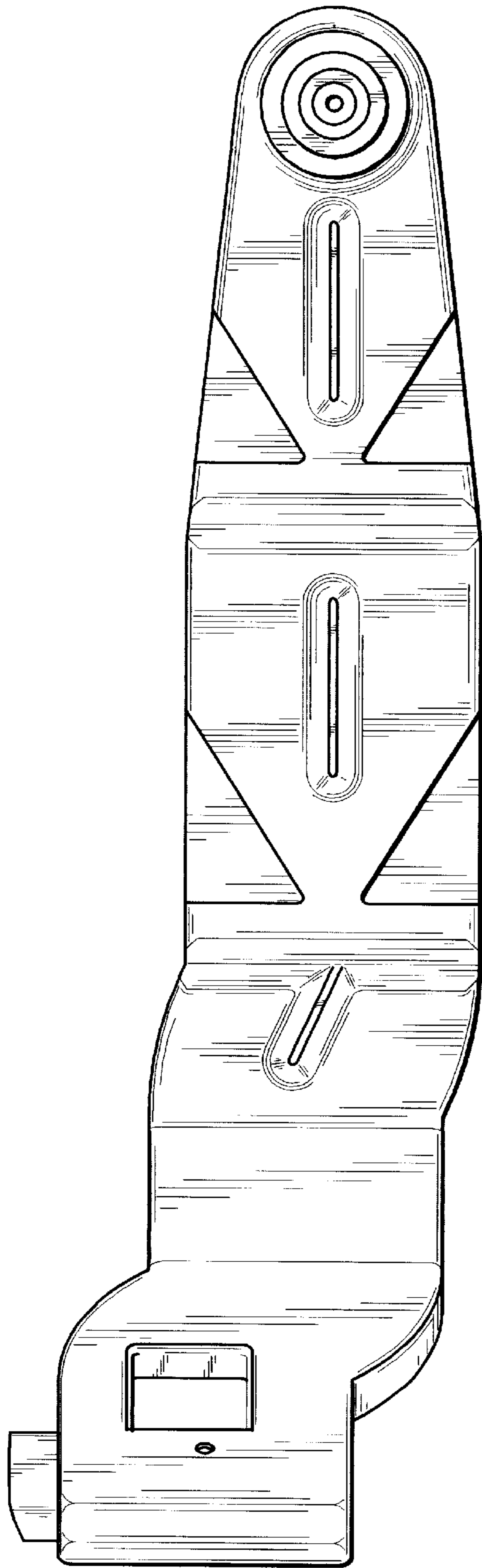
4,512,239 4/1985 Watanabe et al. .

**1 Claim, 5 Drawing Sheets**

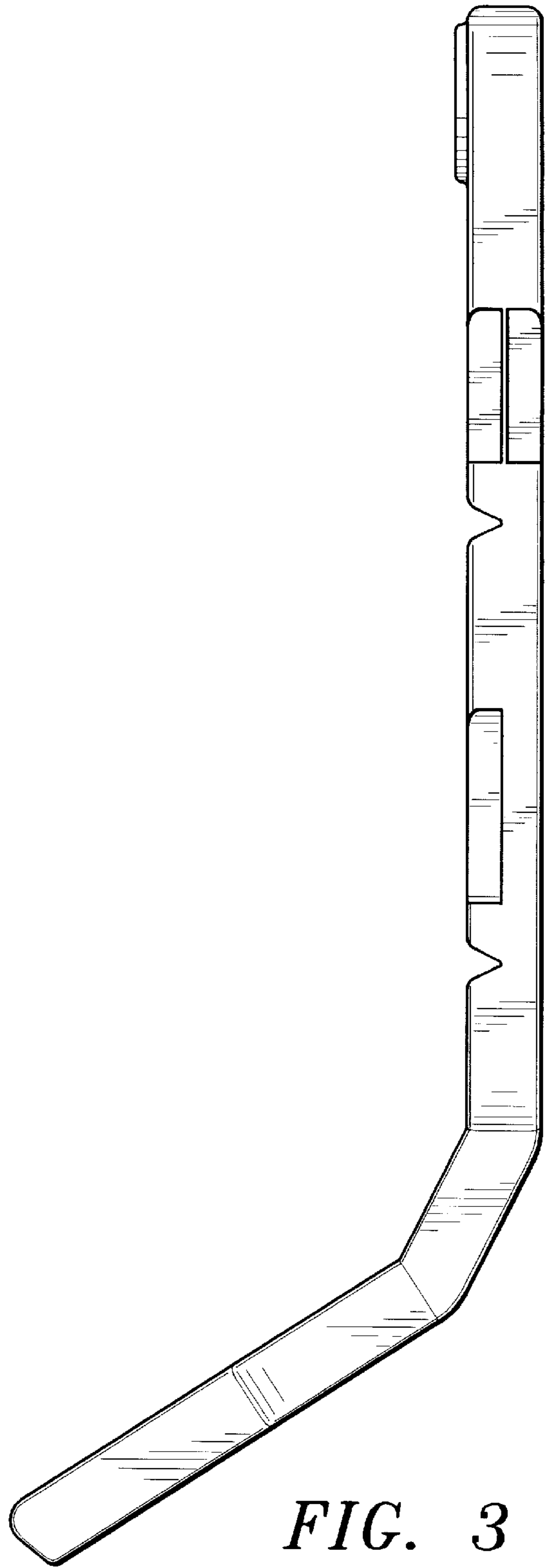




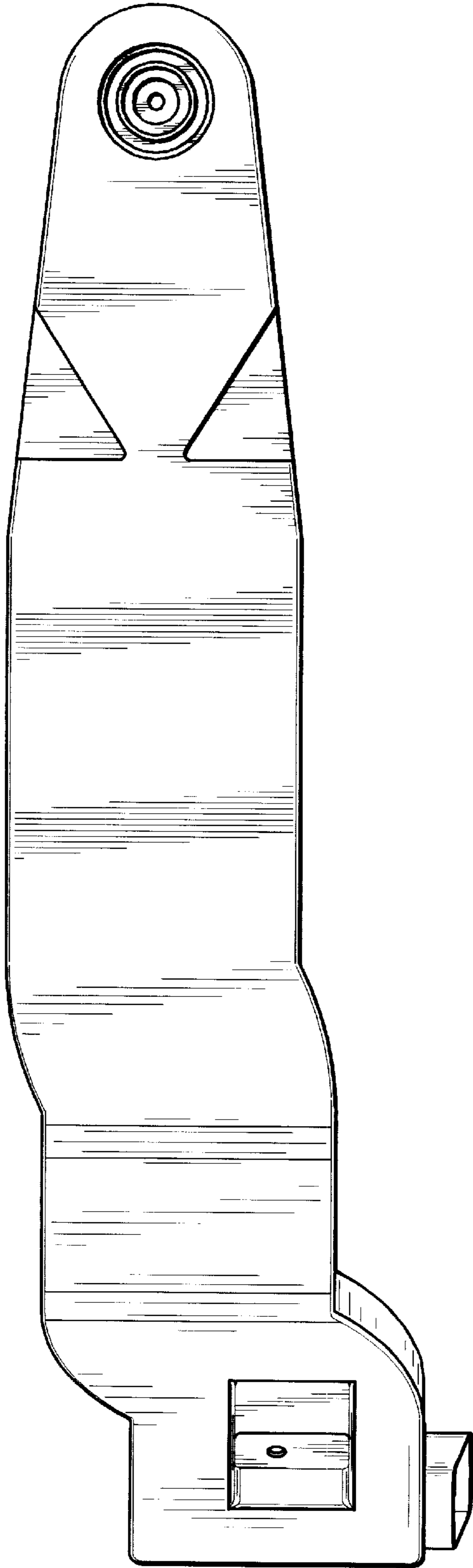
*FIG. 1*



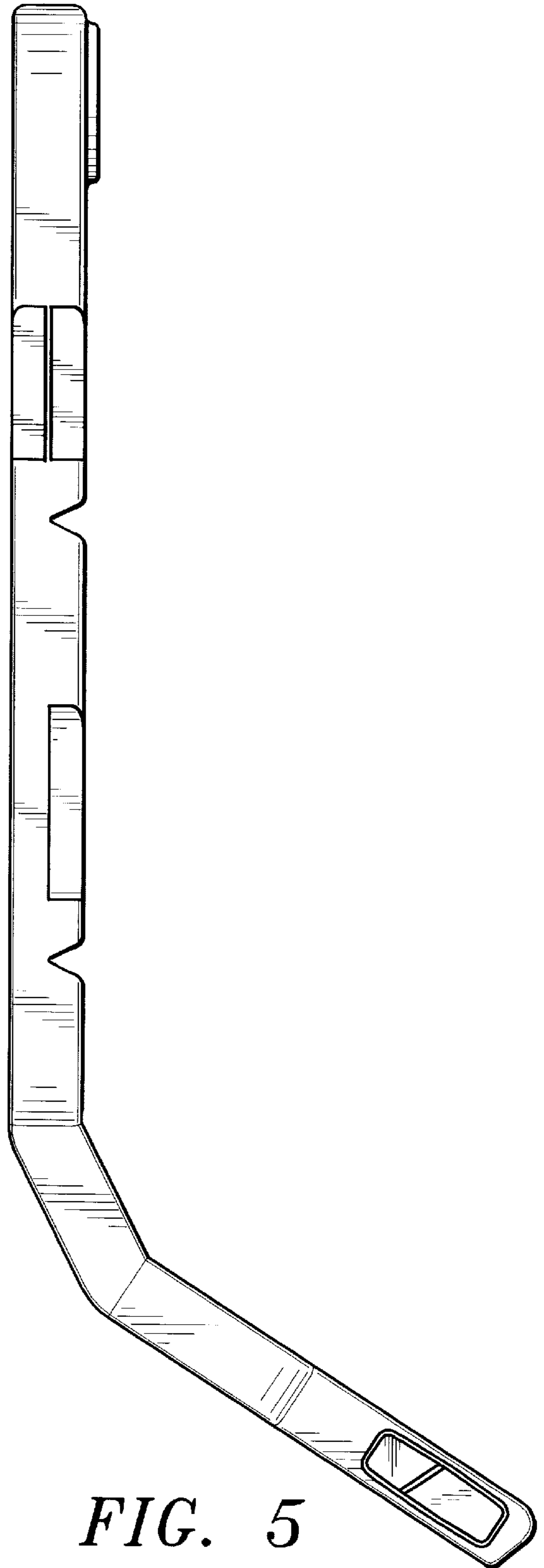
*FIG. 2*



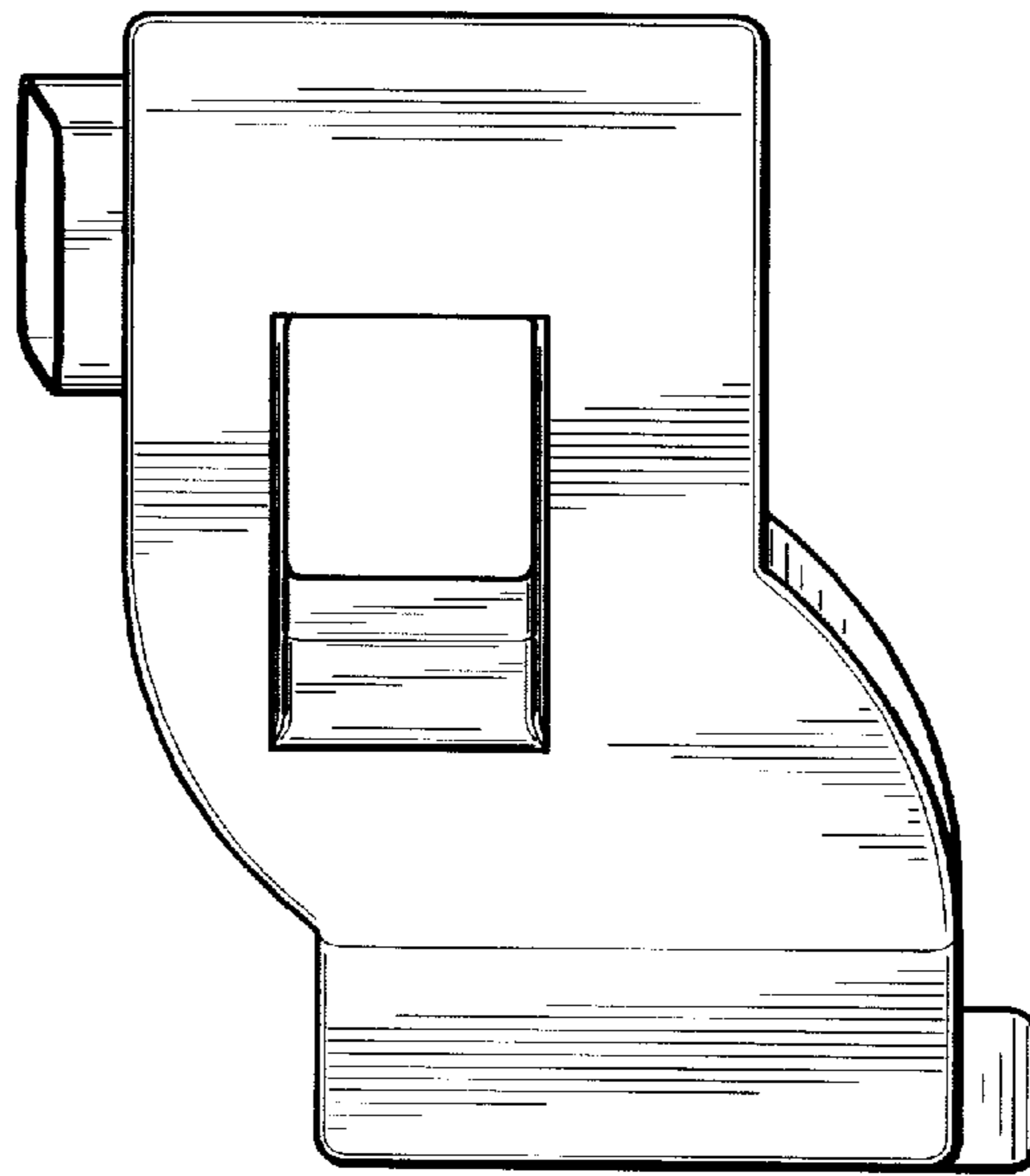
*FIG. 3*



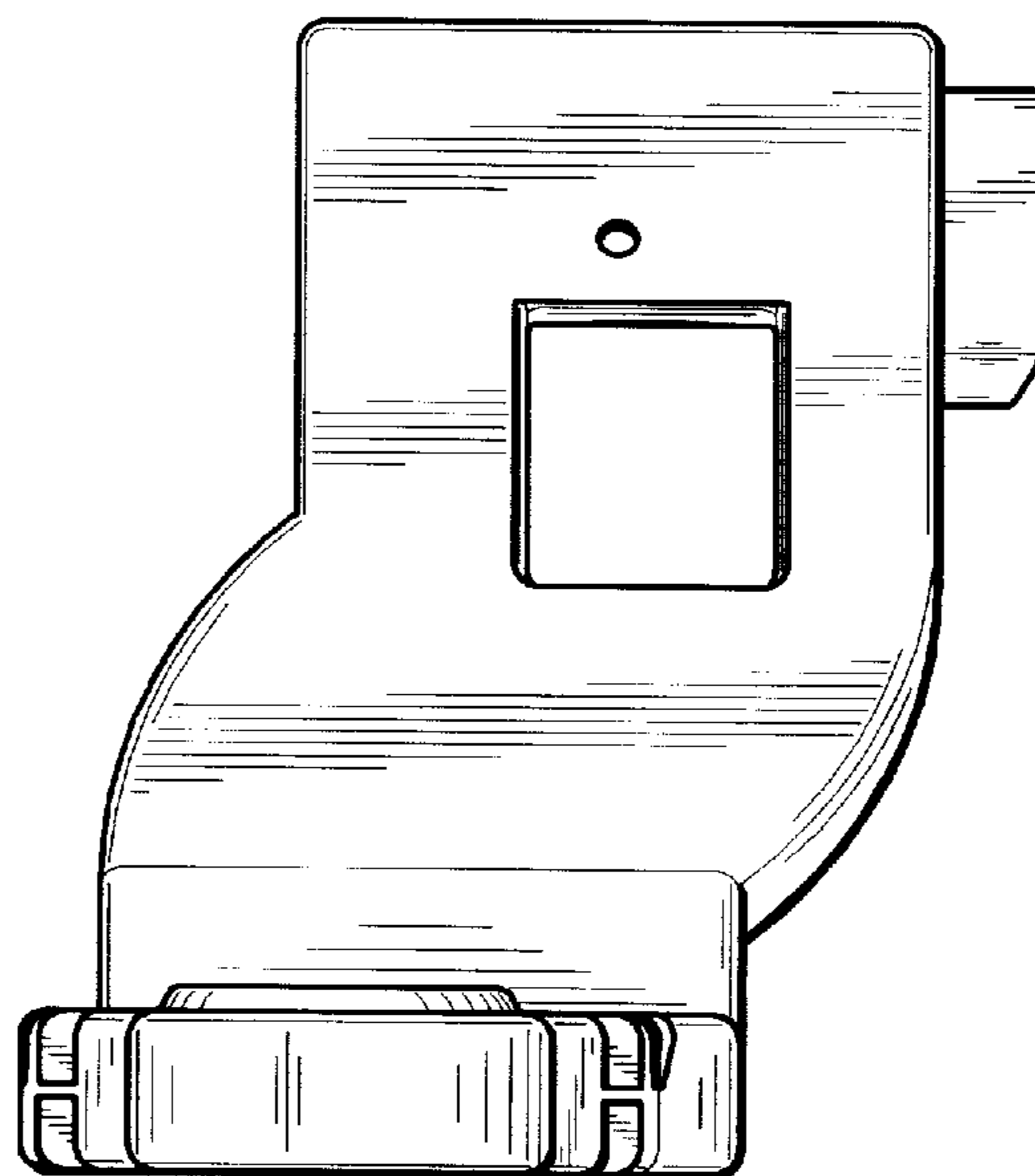
*FIG. 4*



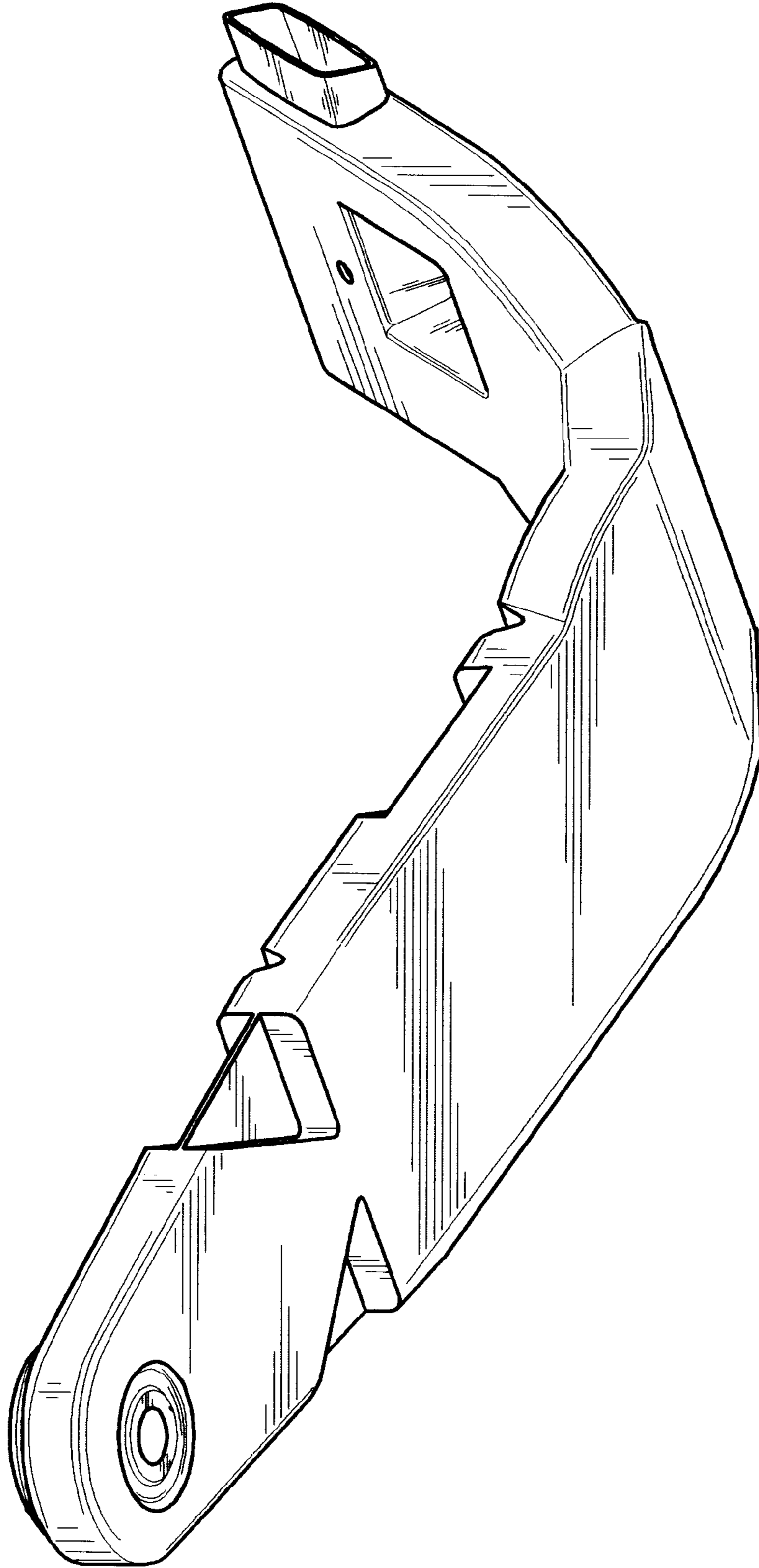
*FIG. 5*



*FIG. 6*



*FIG. 7*



*FIG. 8*