



US00D409211S

**United States Patent** [19]  
**Hidaka**

[11] **Patent Number: Des. 409,211**  
[45] **Date of Patent: \*\* May 4, 1999**

[54] **CONTACT TIP FOR AN ARC WELDER**

[75] Inventor: **Masato Hidaka**, Kanagawa, Japan

[73] Assignee: **Kabushiki Kaisha S M K**, Japan

[\*\*] Term: **14 Years**

[21] Appl. No.: **29/089,773**

[22] Filed: **Jun. 23, 1998**

**Related U.S. Application Data**

[62] Division of application No. 29/062,729, Nov. 22, 1996, abandoned.

[30] **Foreign Application Priority Data**

May 23, 1996 [JP] Japan ..... 8-14772

[51] **LOC (6) Cl.** ..... **15-08**

[52] **U.S. Cl.** ..... **D15/144**

[58] **Field of Search** ..... D15/138, 139,  
D15/144, 144.1, 144.2; 219/70, 137.44,  
137.52

[56] **References Cited**

**U.S. PATENT DOCUMENTS**

D. 290,807 7/1987 Nippert ..... D15/144 X

*Primary Examiner*—Antoine Duval Davis

*Attorney, Agent, or Firm*—Schwegman, Lundberg,  
Woessner & Kluth, P.A.

[57] **CLAIM**

The ornamental design for a “contact tip for an arc welder”, as shown and described.

**DESCRIPTION**

FIG. 1 is a front elevational view of a contact tip for an arc welder showing the applicant's new design;  
FIG. 2 is a rear elevational view thereof;  
FIG. 3 is a top plan view thereof;  
FIG. 4 is a bottom view thereof;

FIG. 5 is a left side elevational view thereof;  
FIG. 6 is a right side elevational view thereof;  
FIG. 7 is a longitudinal sectional view along the line 1—1 in FIG. 3;  
FIG. 8 is a front perspective view thereof;  
FIG. 9 is a similar view in FIG. 8 but further showing by an imaginary line the first type of the adapter into which the leg portion of the contact tip is screw-fitted;  
FIG. 10 is a similar view in FIG. 9 but showing by an imaginary line the second type of the adapter;  
FIG. 11 is a front elevational view of a second embodiment of a contact tip for an arc welding showing the applicant's new design;  
FIG. 12 is a rear elevational view thereof;  
FIG. 13 is a top plan view thereof;  
FIG. 14 is a bottom plan view thereof;  
FIG. 15 is a left side elevational view thereof;  
FIG. 16 is a right side elevational view thereof;  
FIG. 17 is a longitudinal sectional view thereof along the line 2—2 in FIG. 13;  
FIG. 18 is a front perspective view thereof;  
FIG. 19 is a similar view in FIG. 18 but further showing by an imaginary line the first type of the adapter into which the leg portion of the contact tip is screw-fitted;  
FIG. 20 is a similar view in FIG. 19 but showing by an imaginary line the second type of the adapter;  
FIG. 21 is a front elevational view of a third embodiment of a contact tip for an arc welding showing the applicant's new design;  
FIG. 22 is a rear side elevational view thereof;  
FIG. 23 is a top plan view thereof;  
FIG. 24 is a bottom plan view thereof;  
FIG. 25 is a left side side elevational view thereof;  
FIG. 26 is a right side side elevational view thereof;  
FIG. 27 is a longitudinal sectional view along the line 3—3 in FIG. 23;  
FIG. 28 is a front perspective view thereof;  
FIG. 29 is a similar view in FIG. 28 but further showing by an imaginary line the first type of the adapter into which the leg portion of the contact tip is screw-fitted; and,  
FIG. 30 is a similar view in FIG. 29 but showing by an imaginary line the second type of the adapter.

**1 Claim, 9 Drawing Sheets**

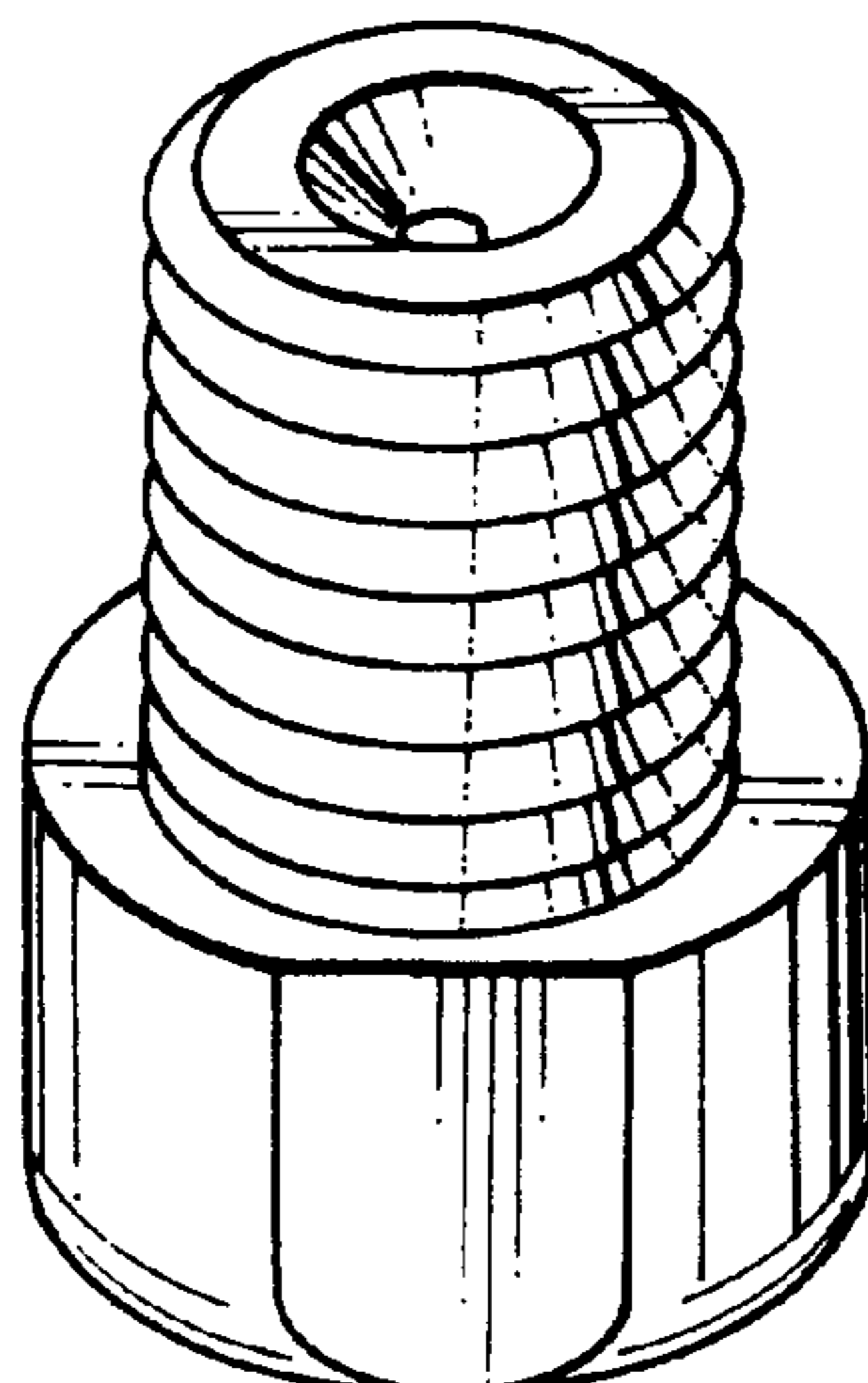

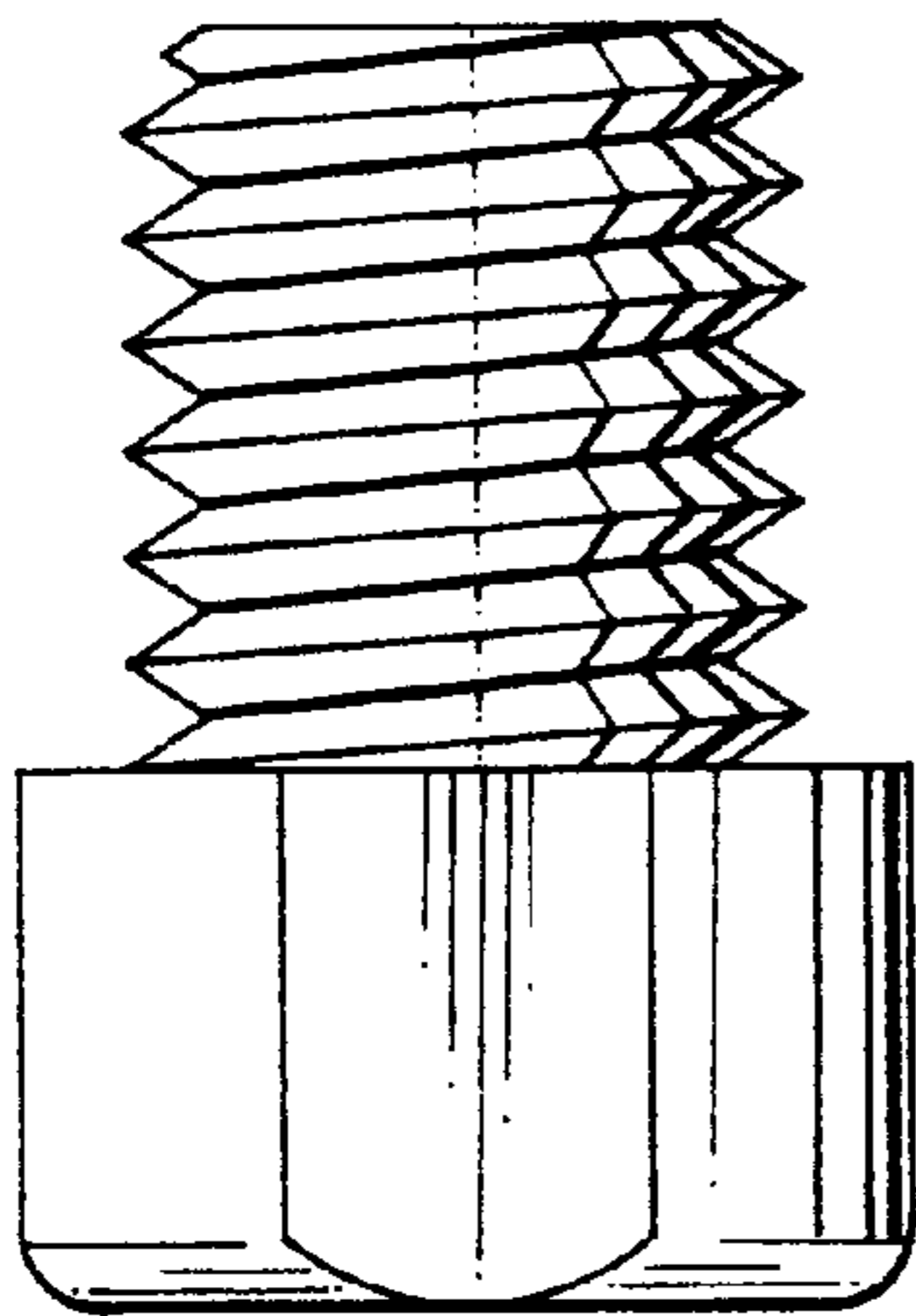

FIG. 1

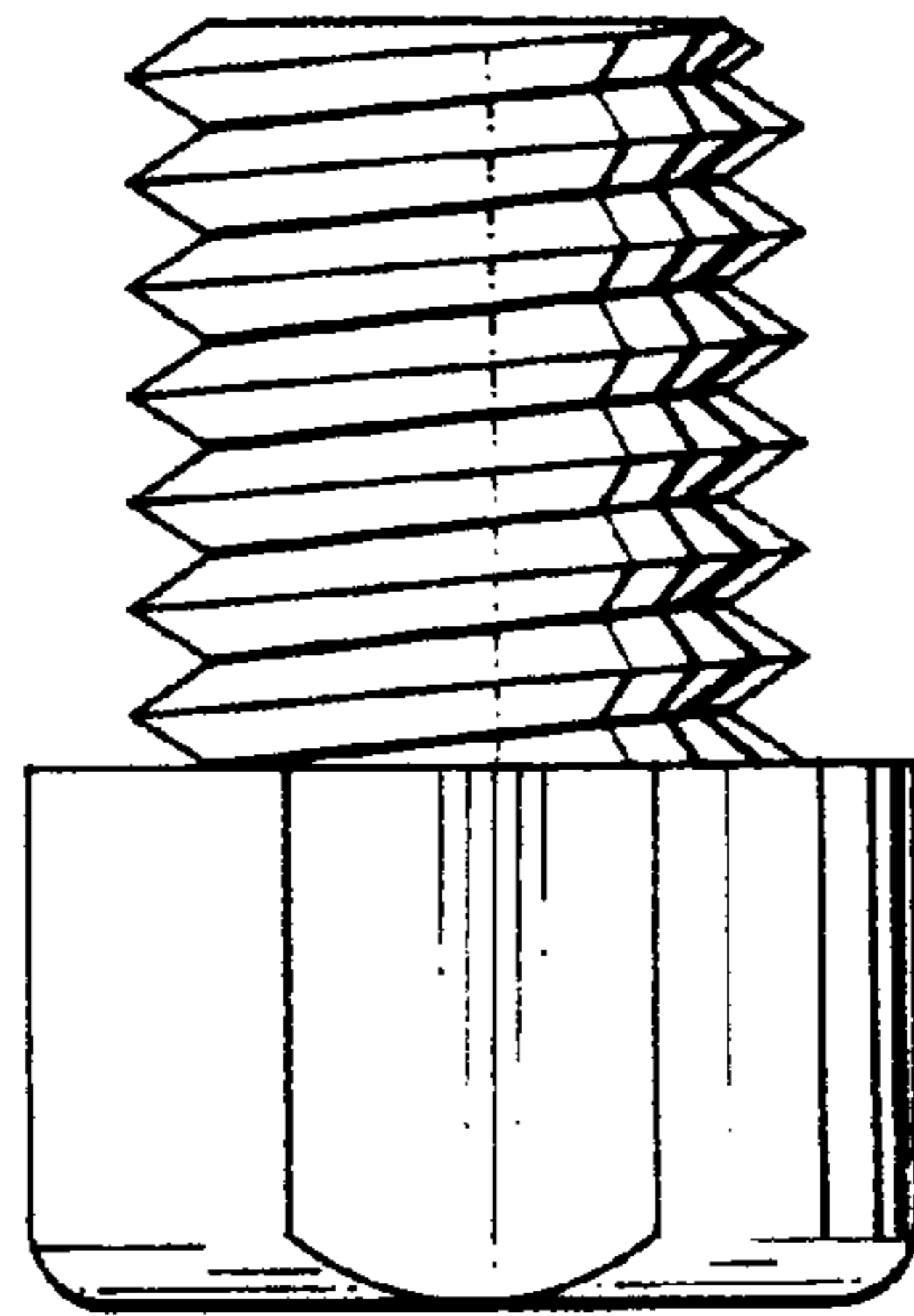

FIG. 2

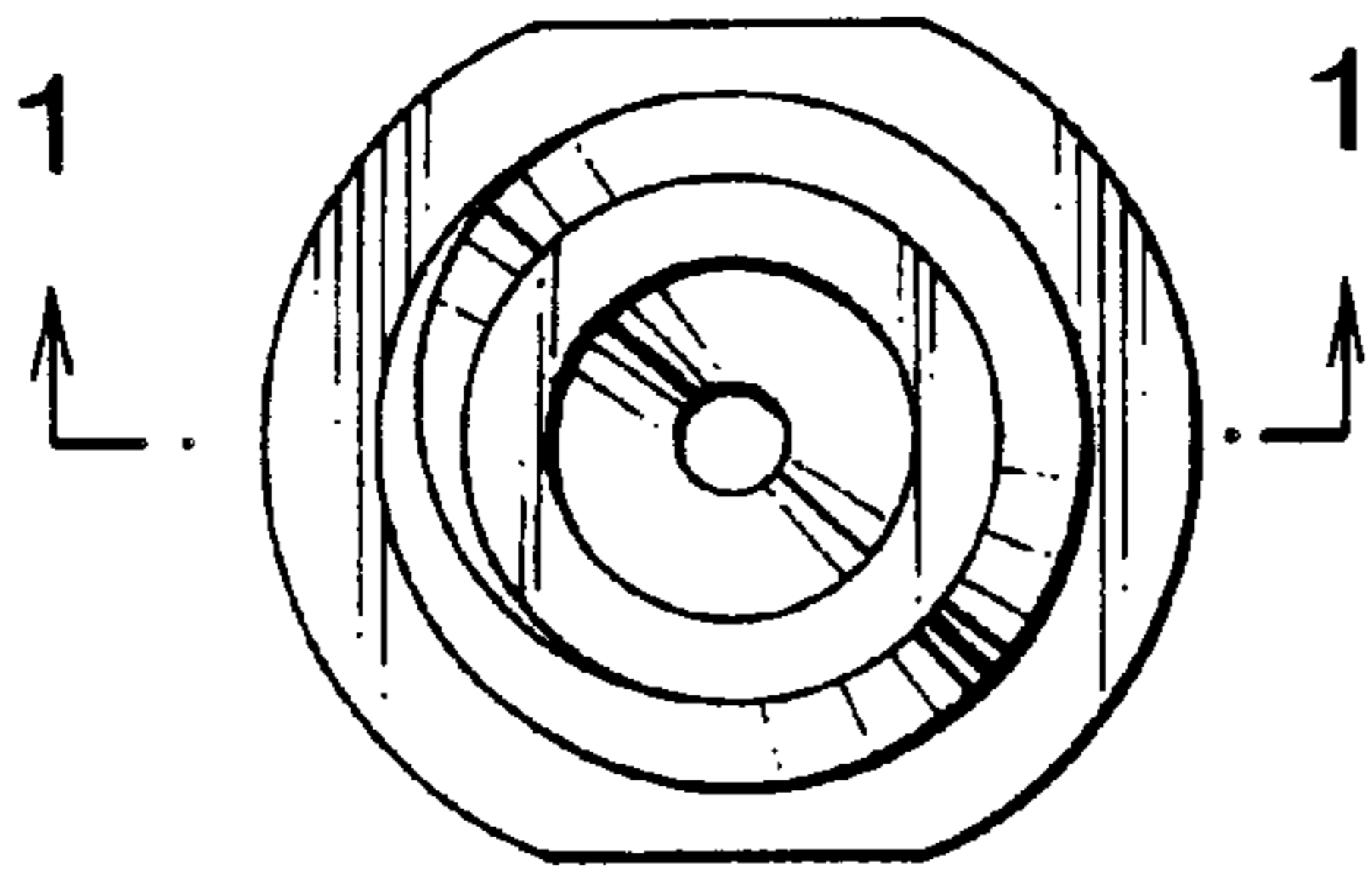

FIG. 3

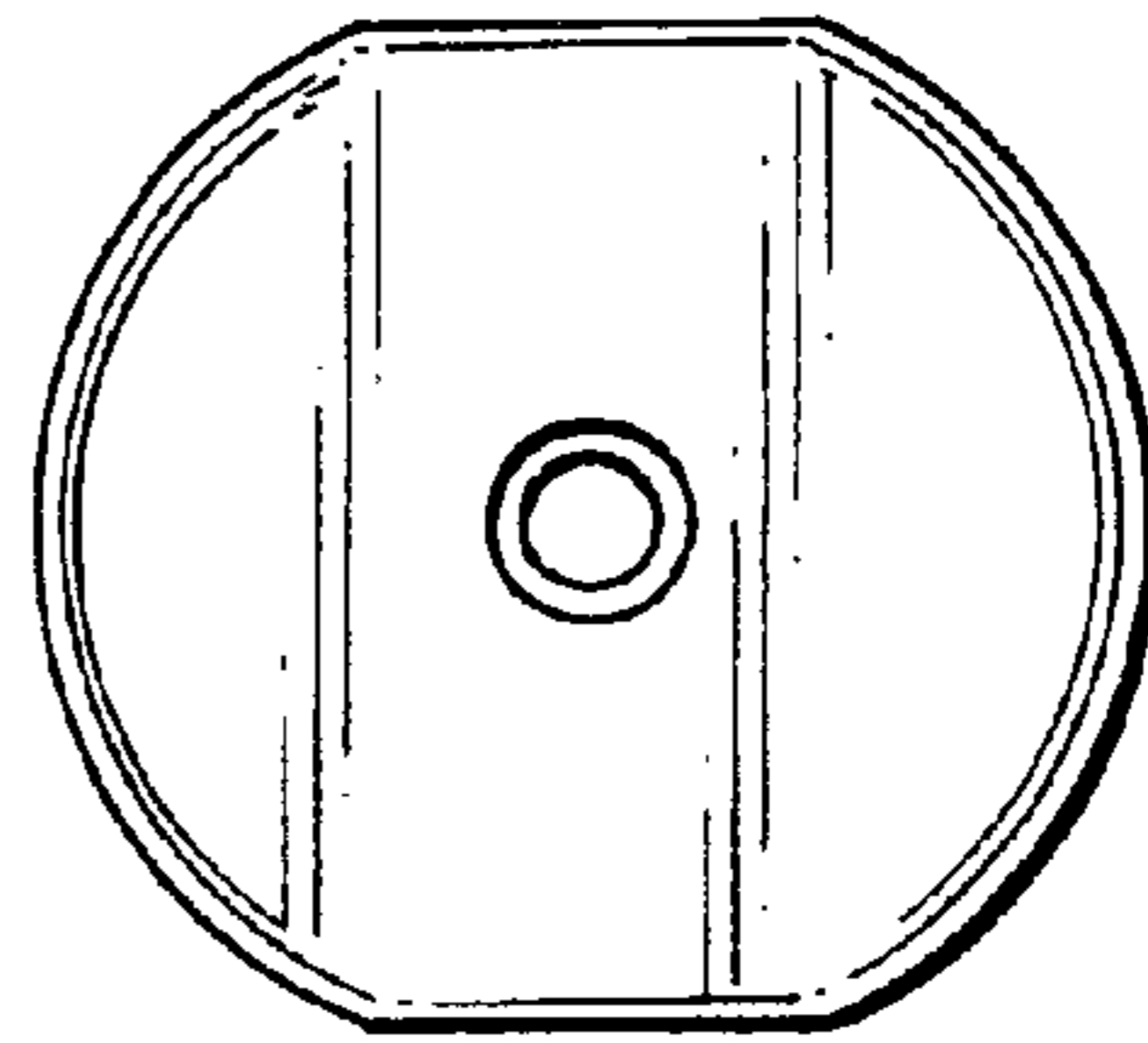

FIG. 4

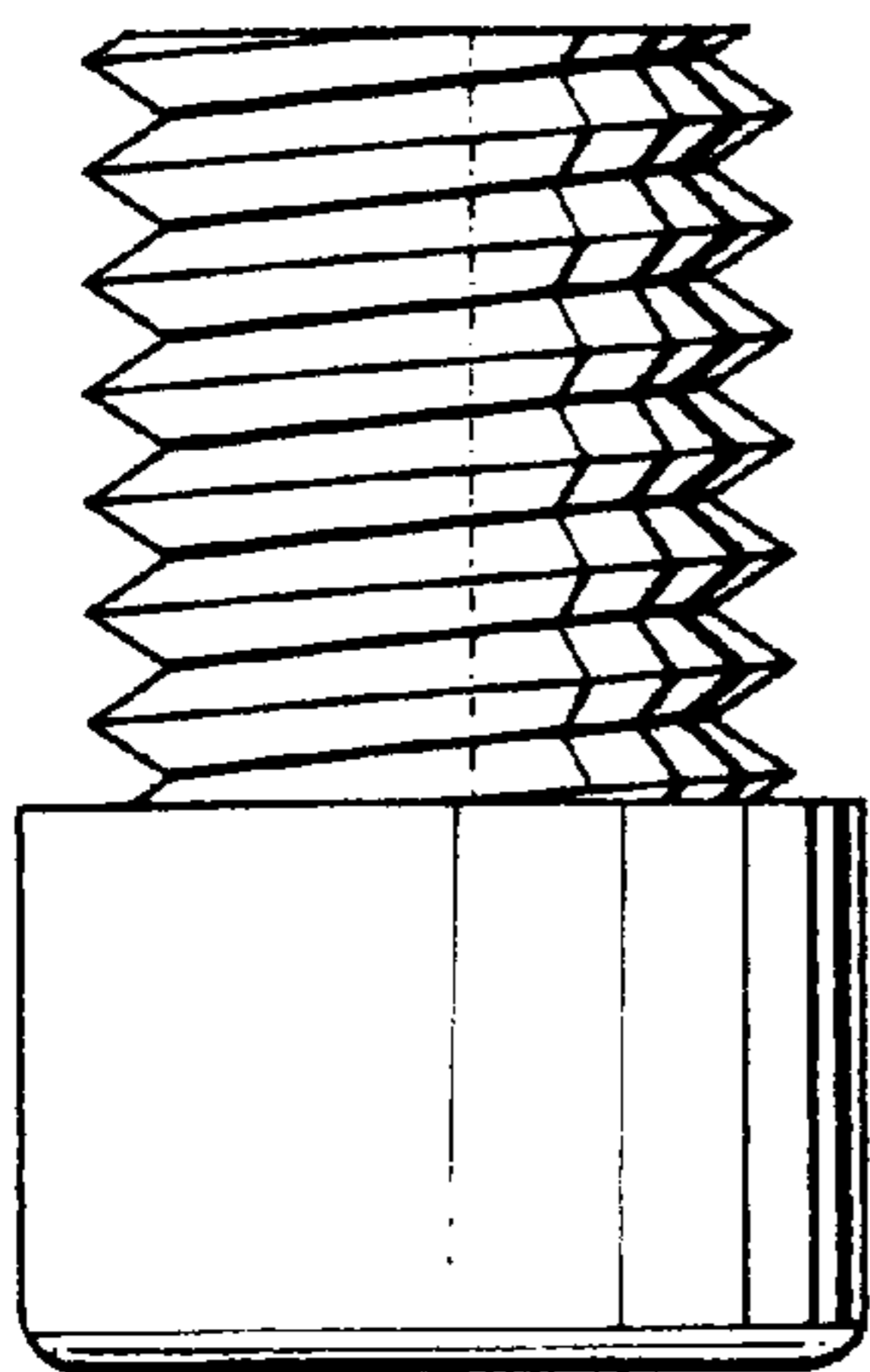

FIG. 5

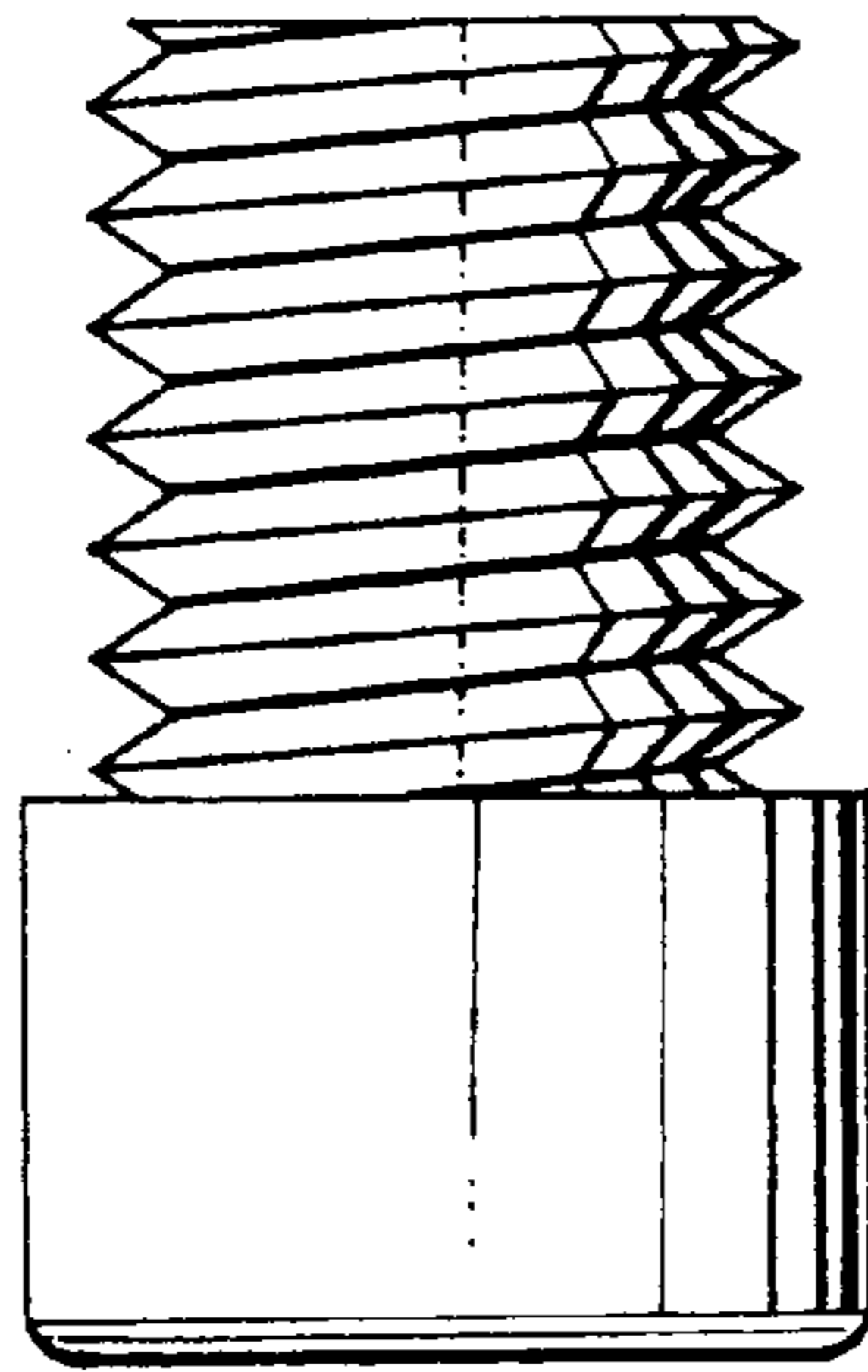

FIG. 6

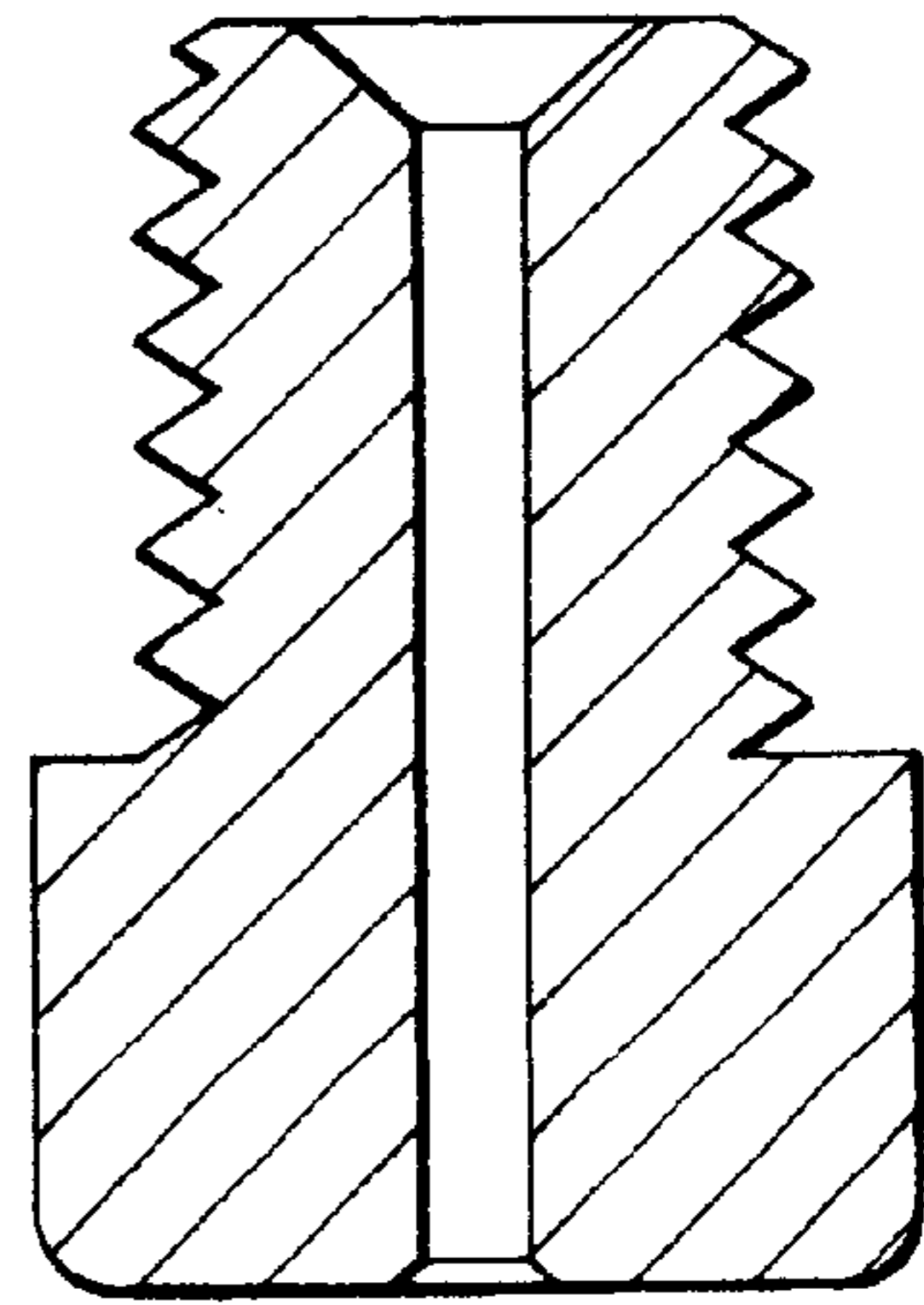

FIG. 7

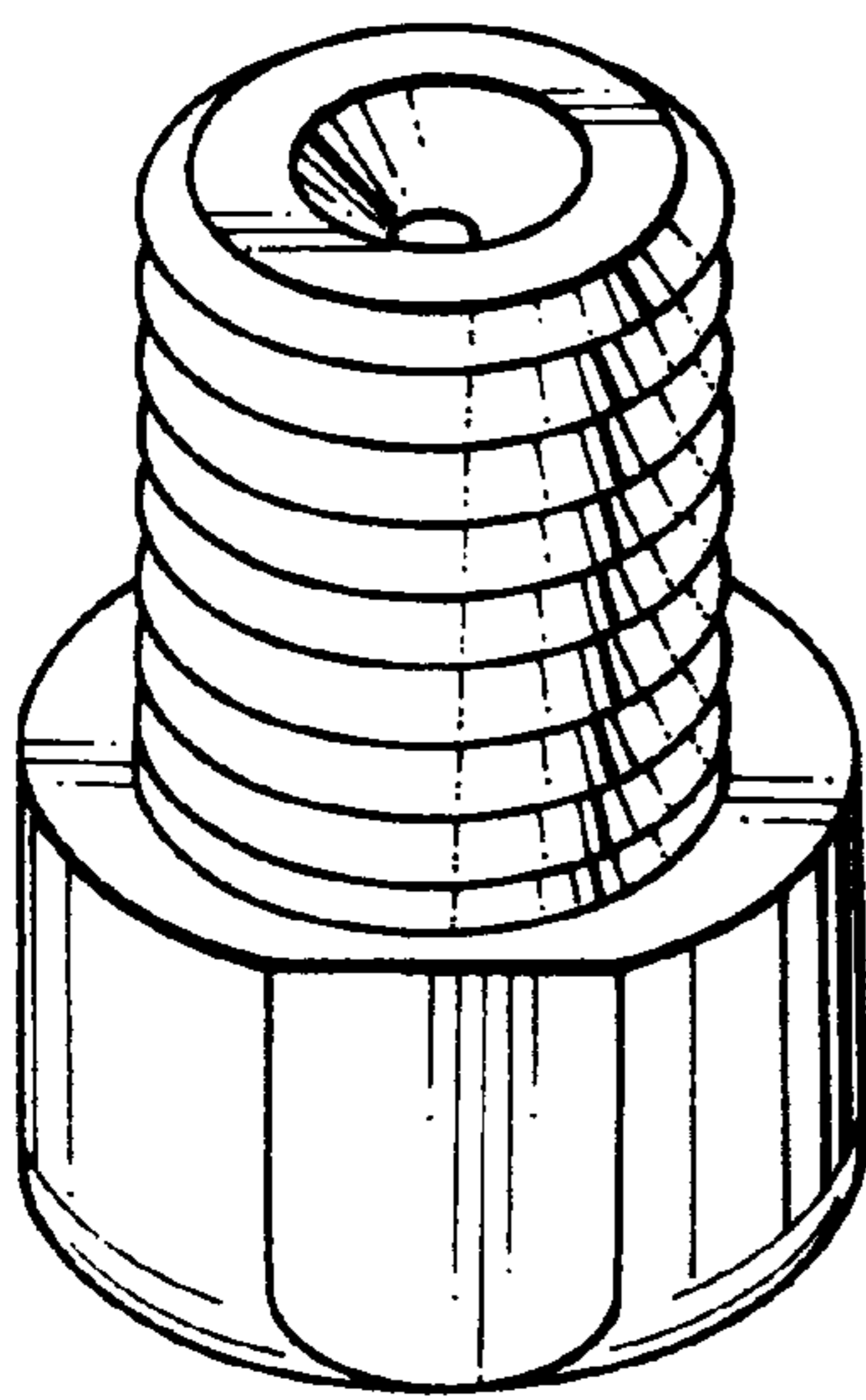

FIG. 8

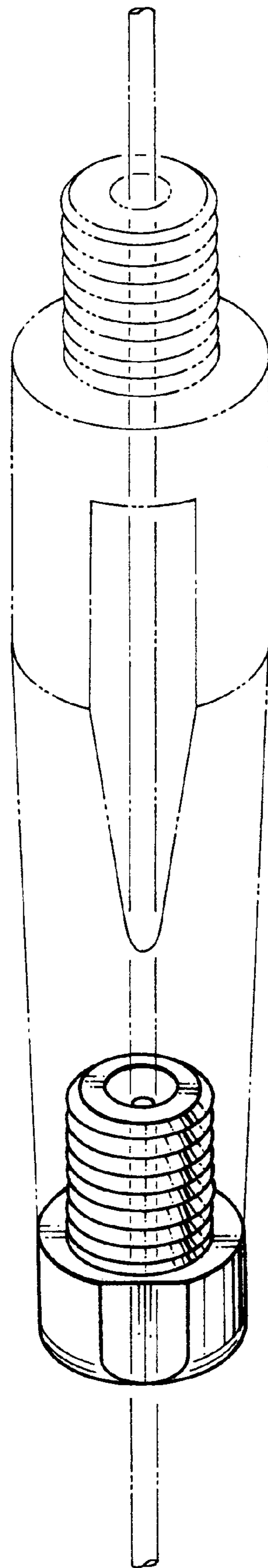

FIG. 9

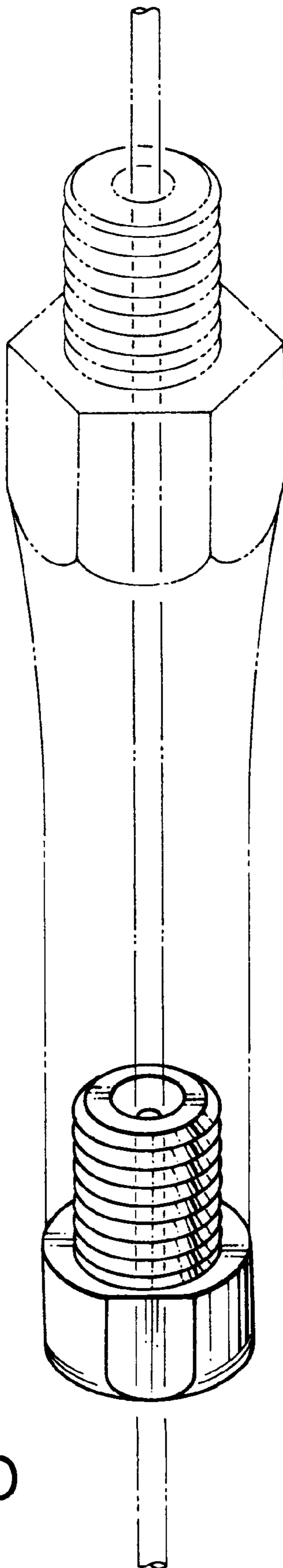

FIG. 10

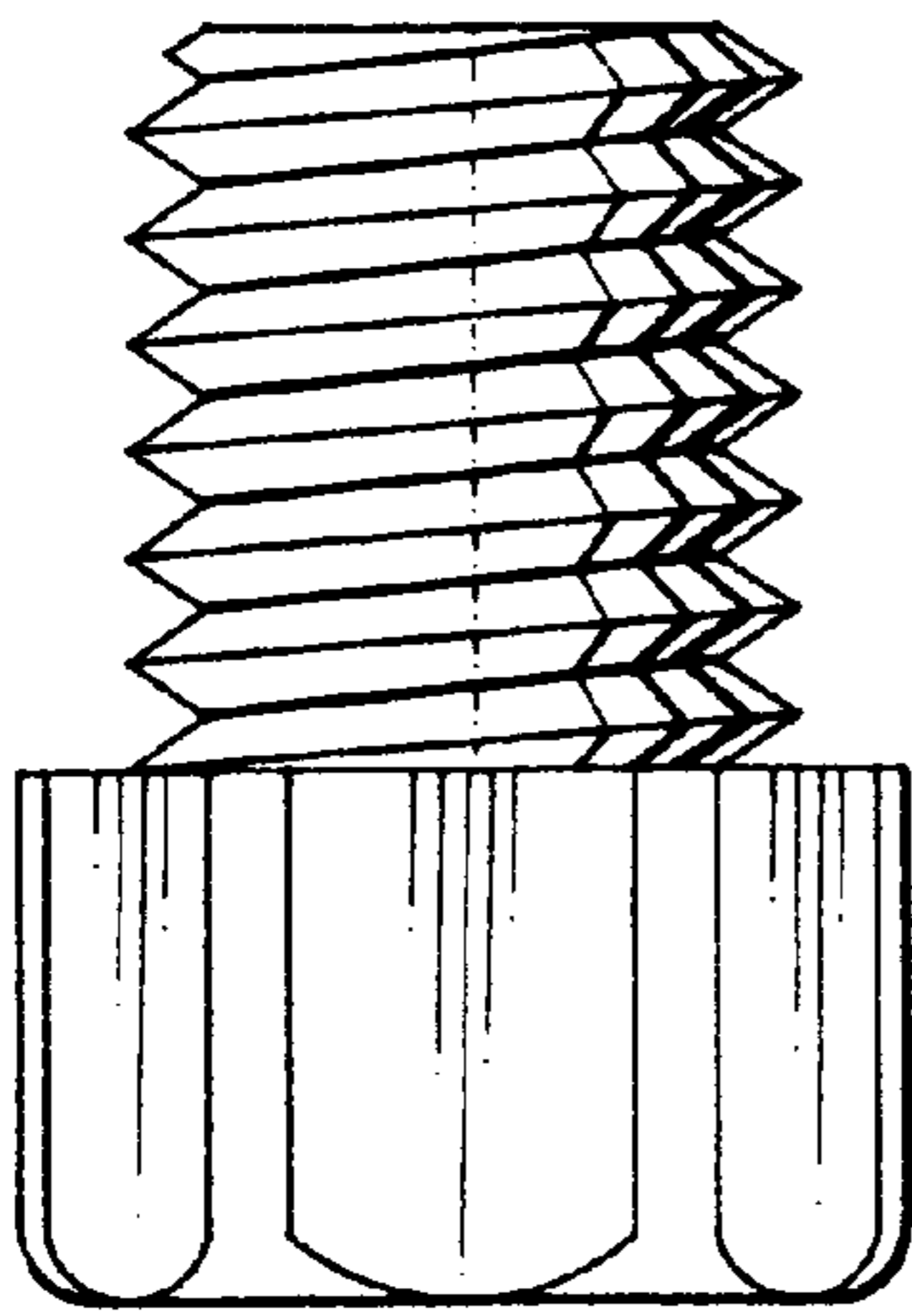

FIG. 11

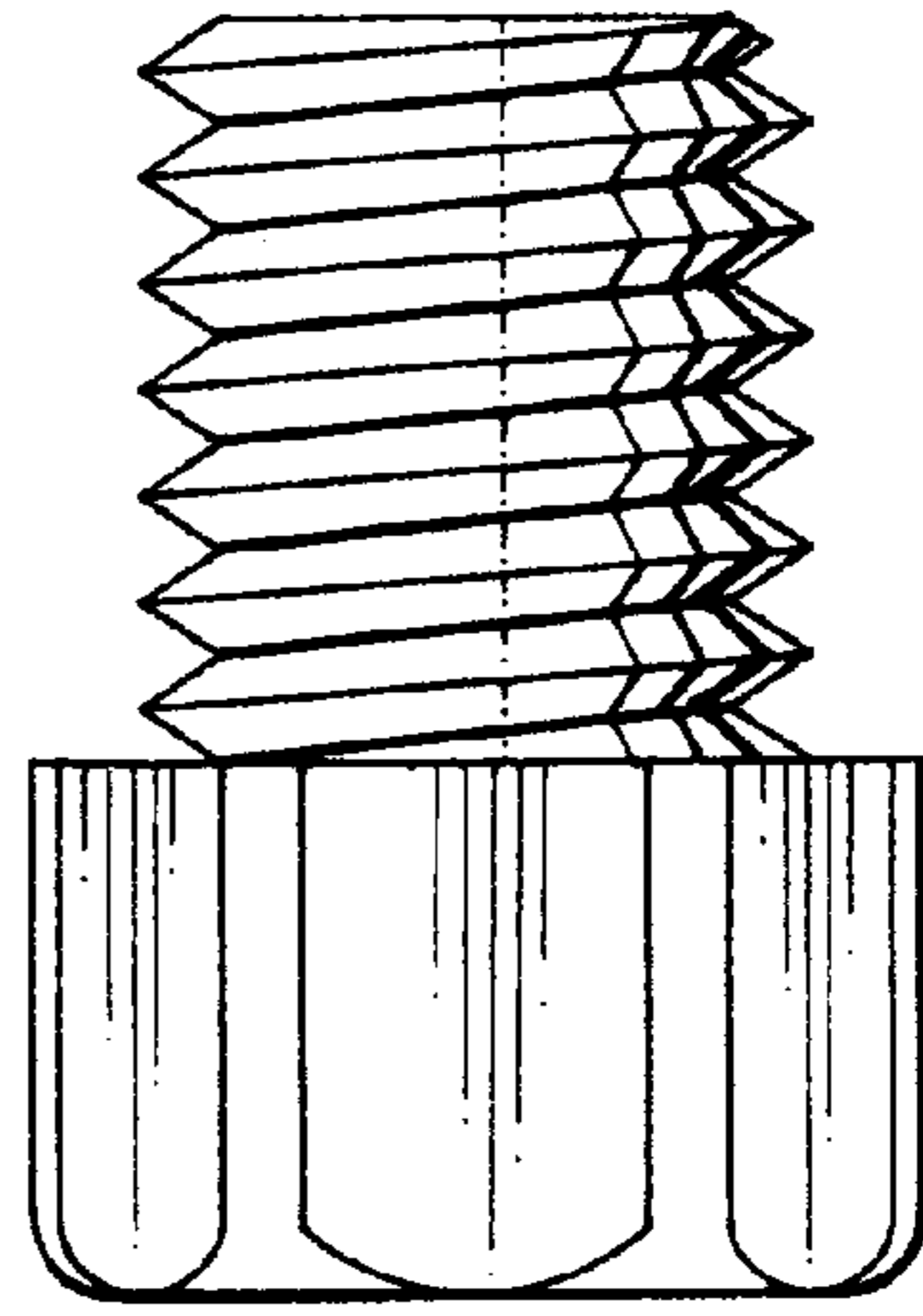

FIG. 12

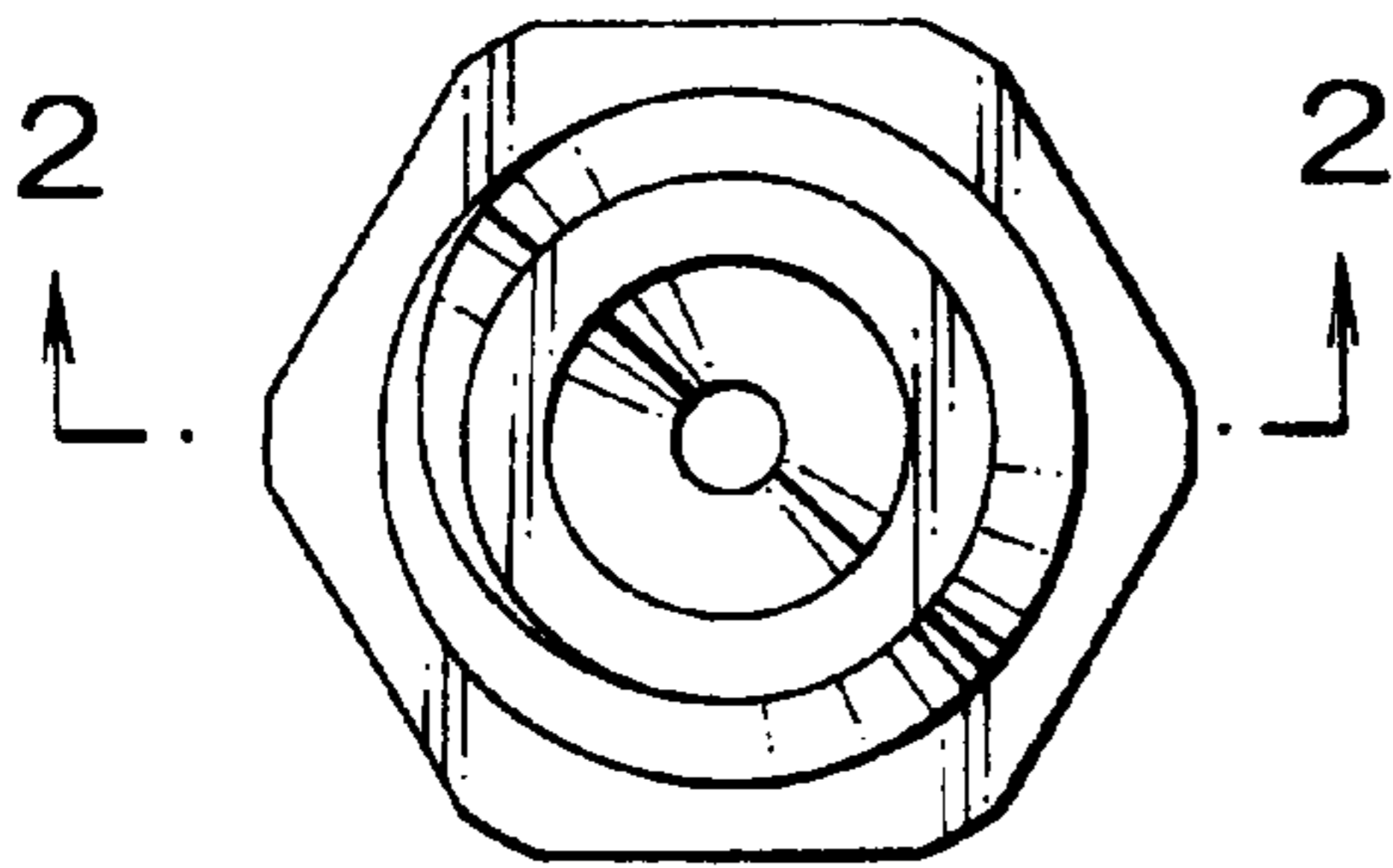

FIG. 13

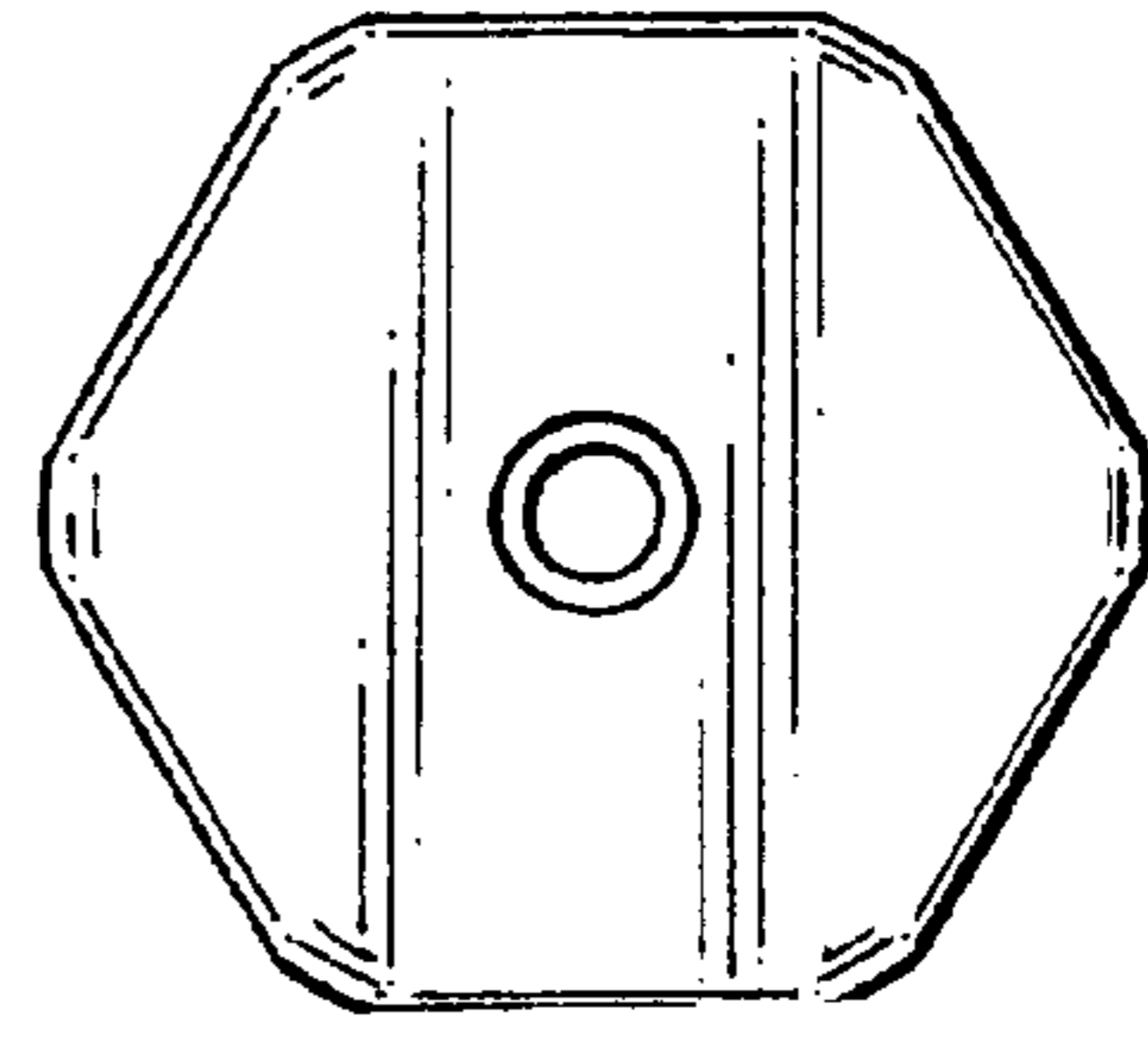

FIG. 14

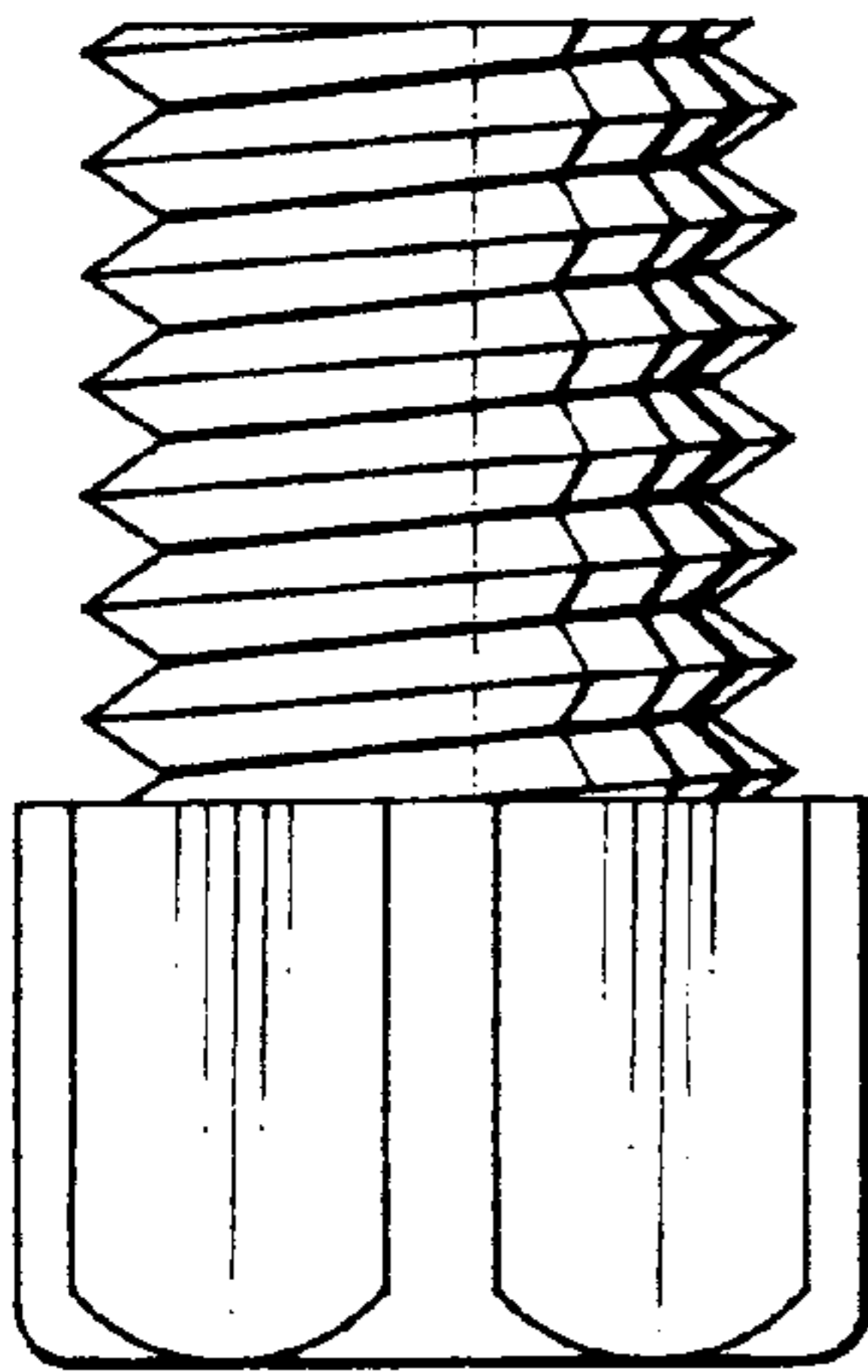

FIG. 15

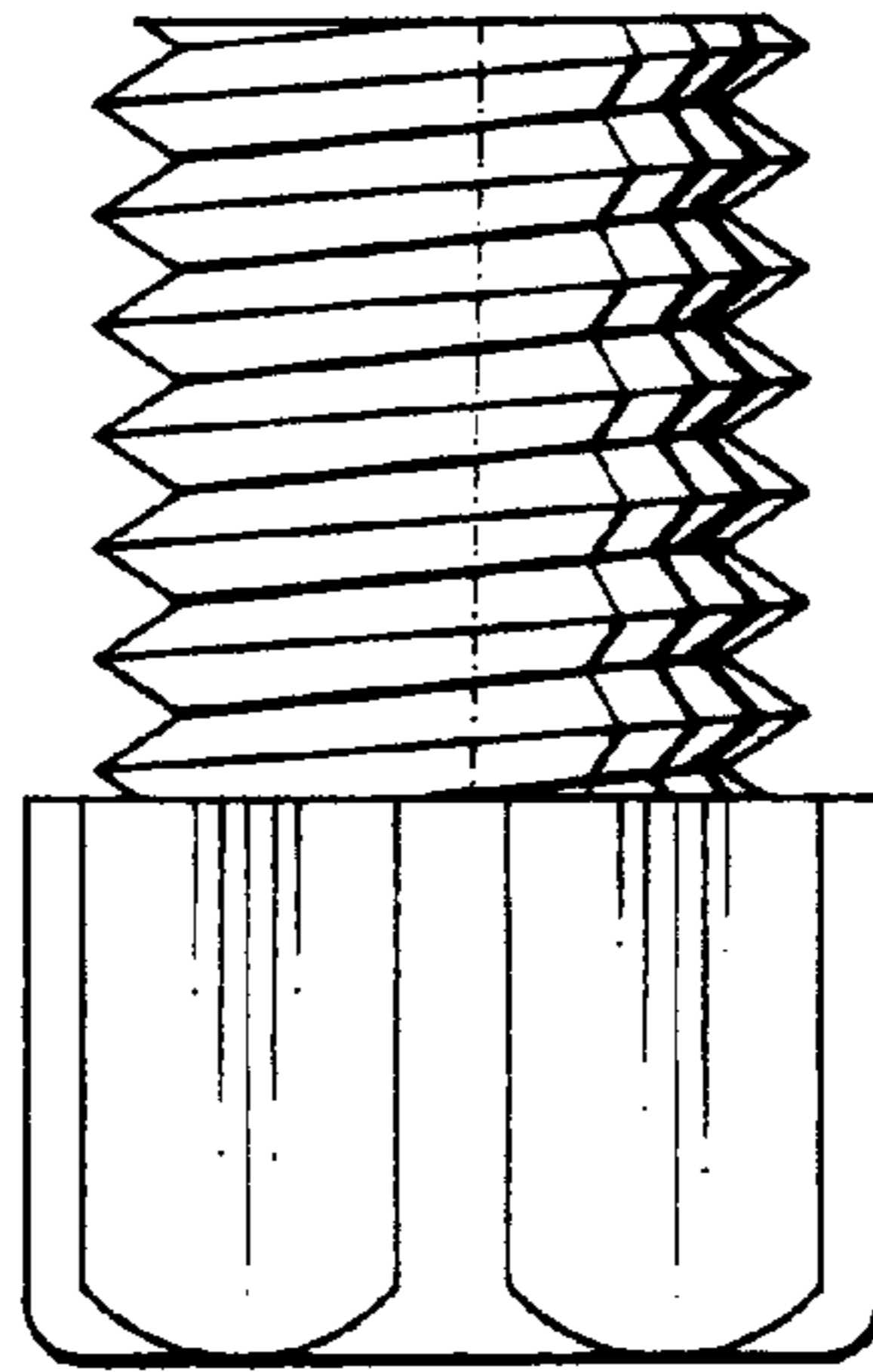

FIG. 16

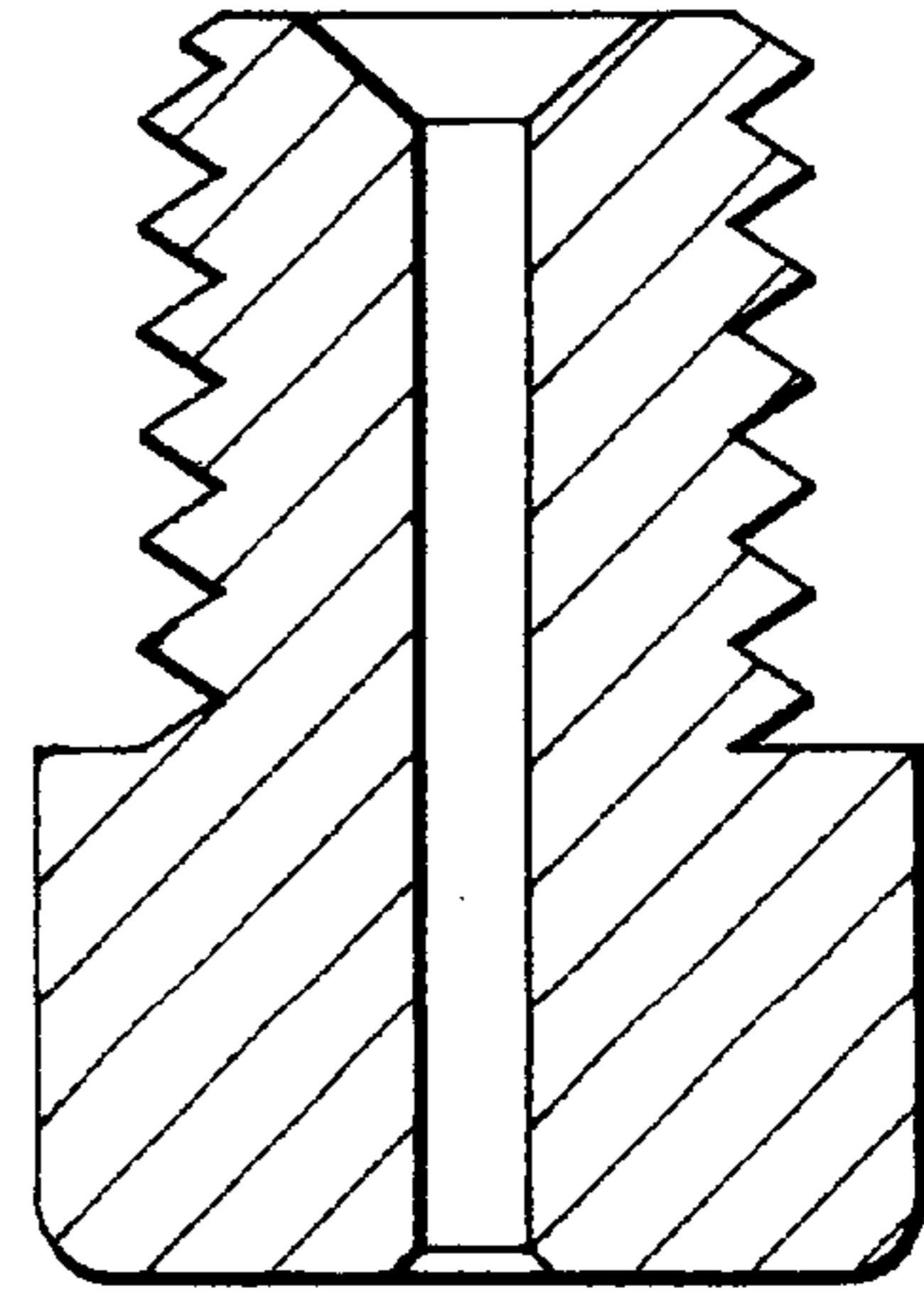

FIG. 17

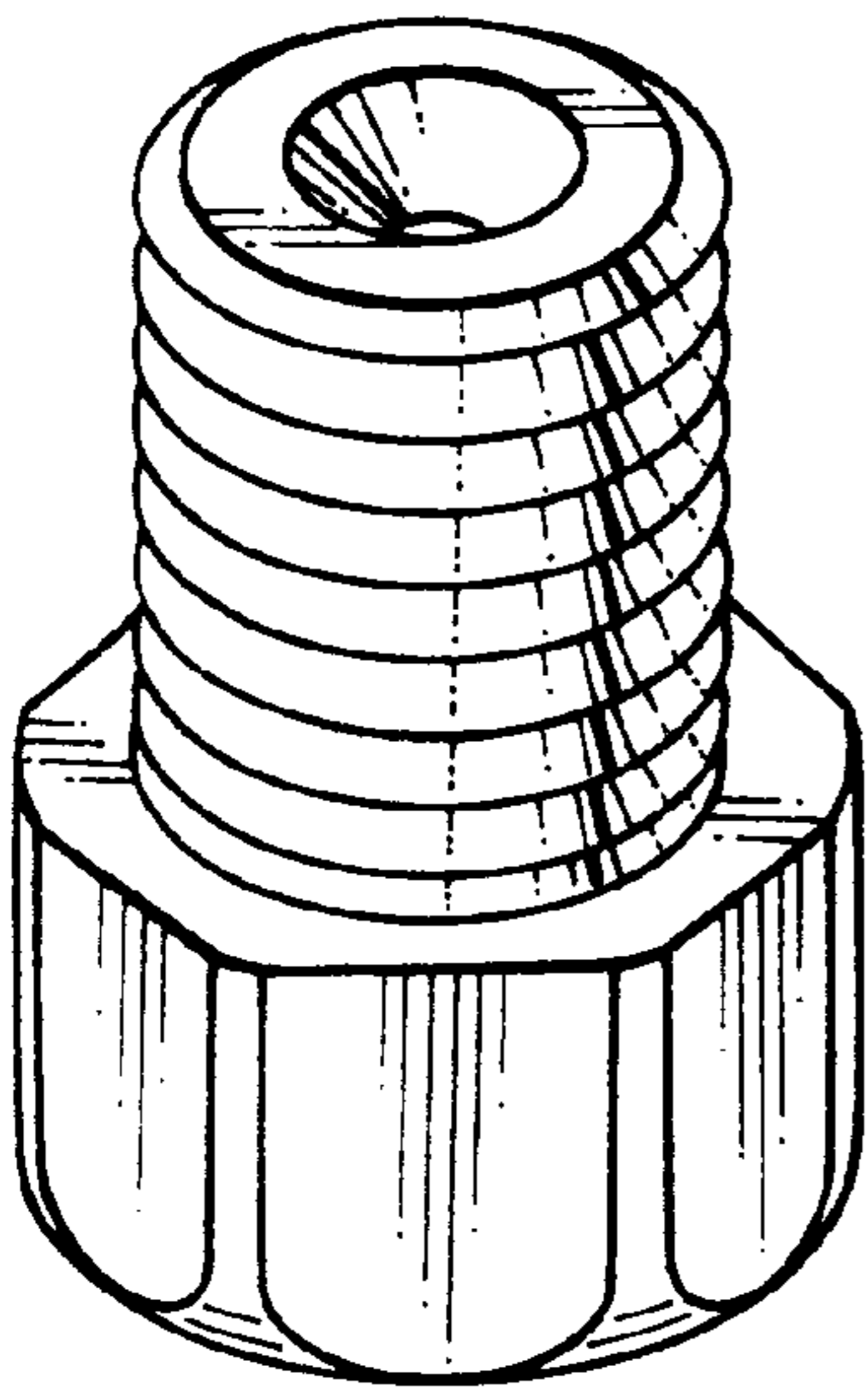

FIG. 18

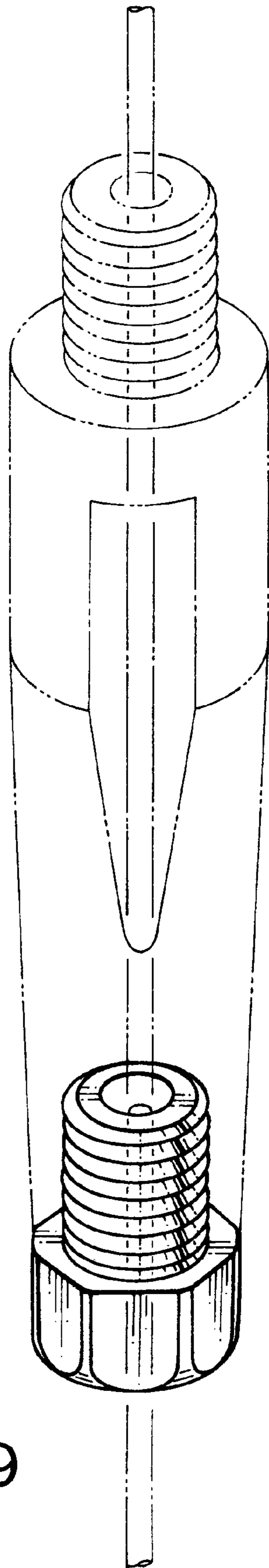

FIG. 19

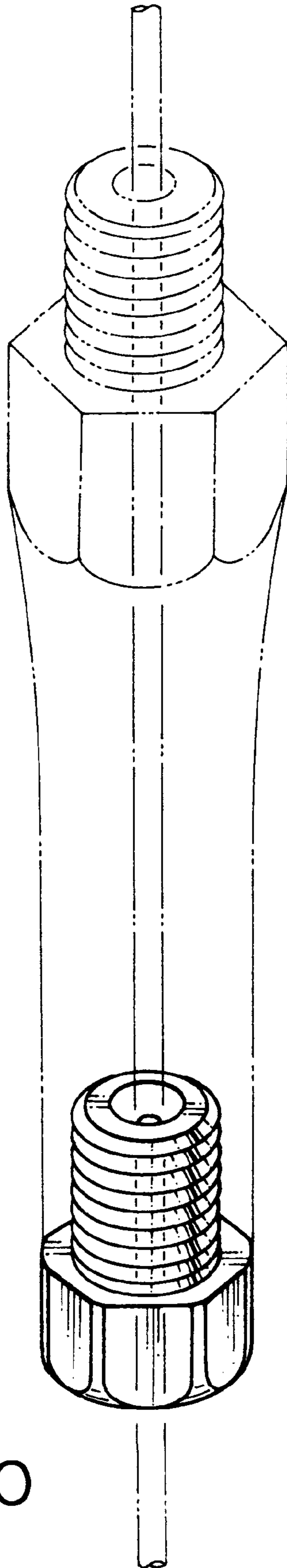

FIG. 20

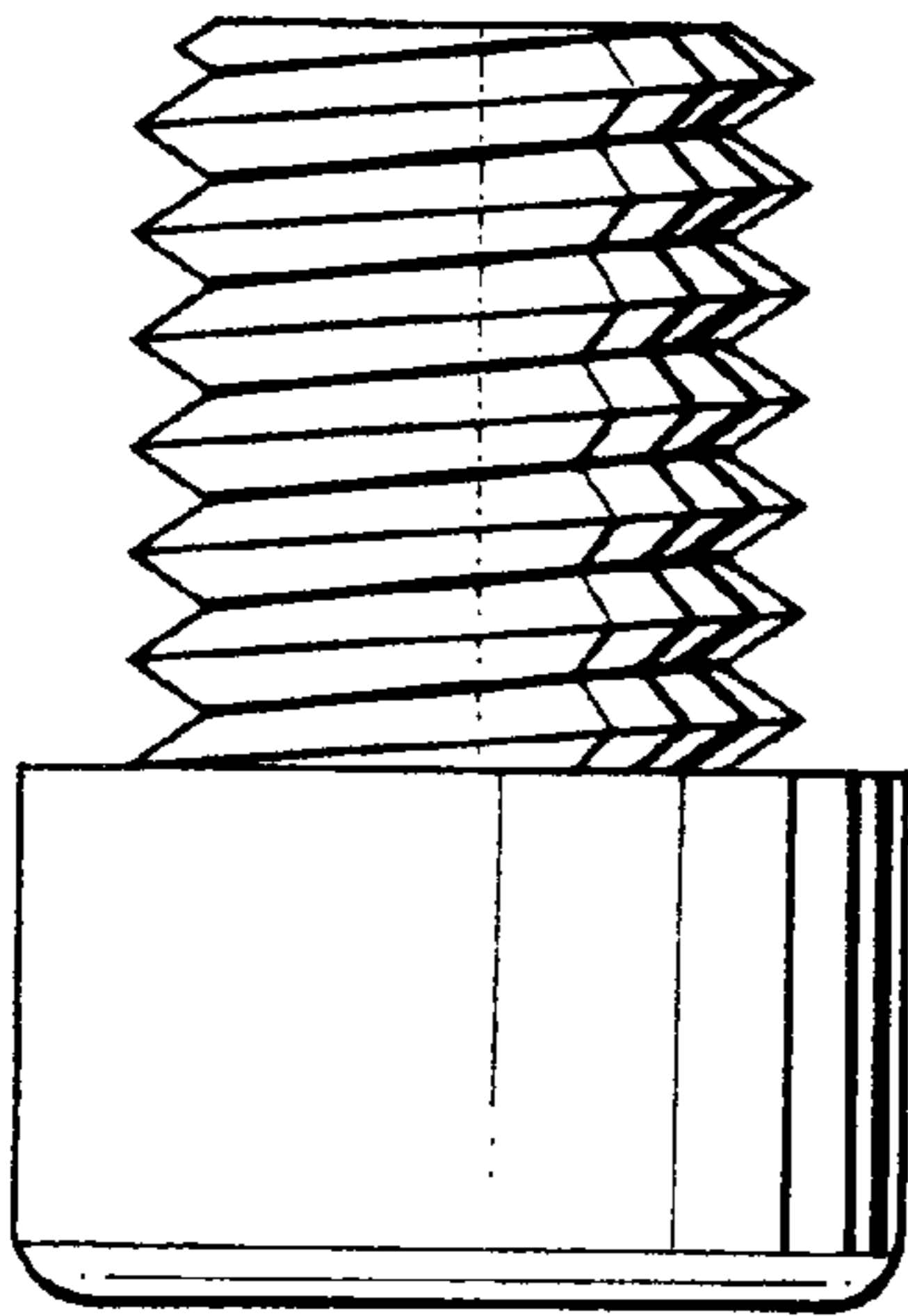

FIG. 21

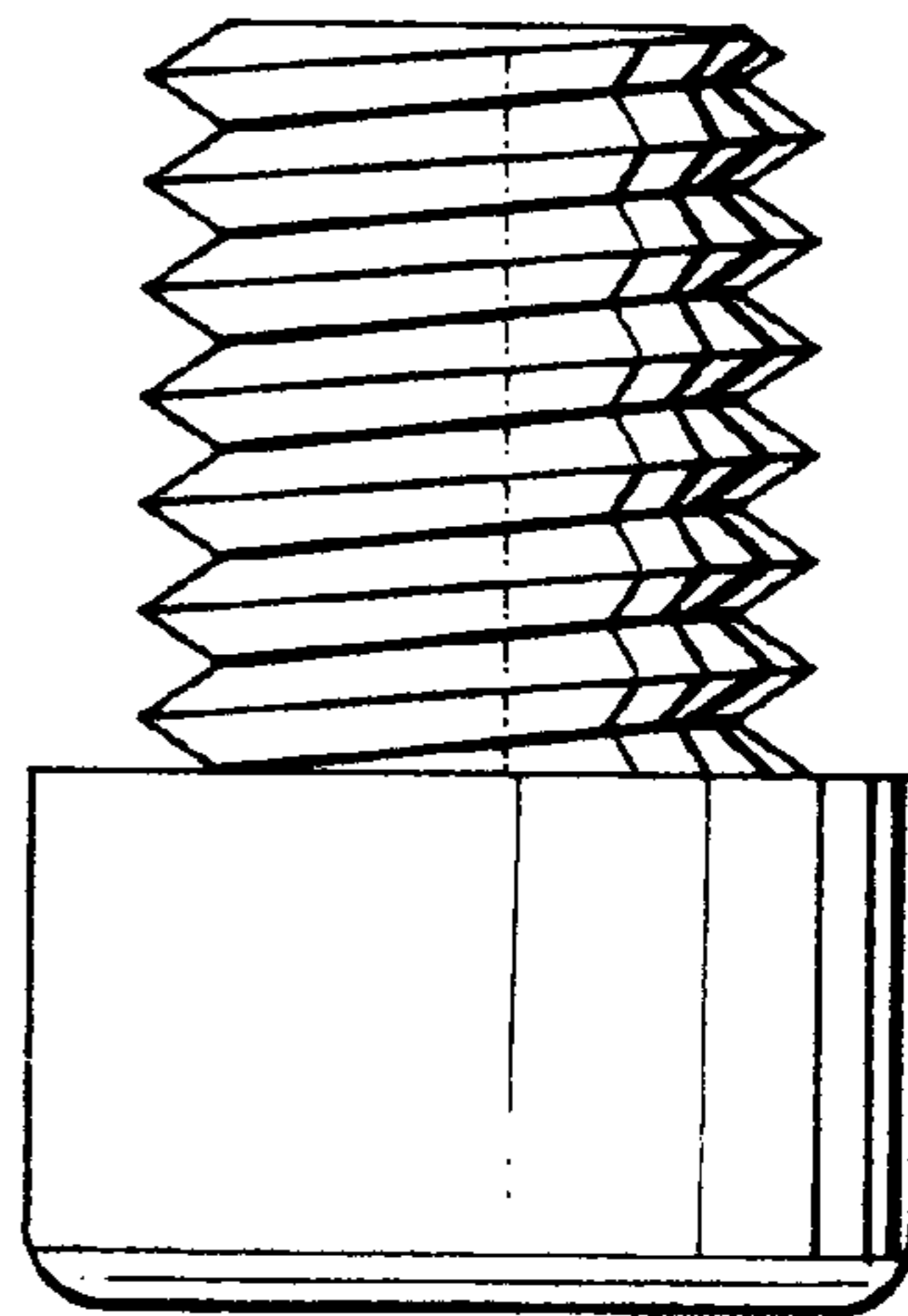

FIG. 22

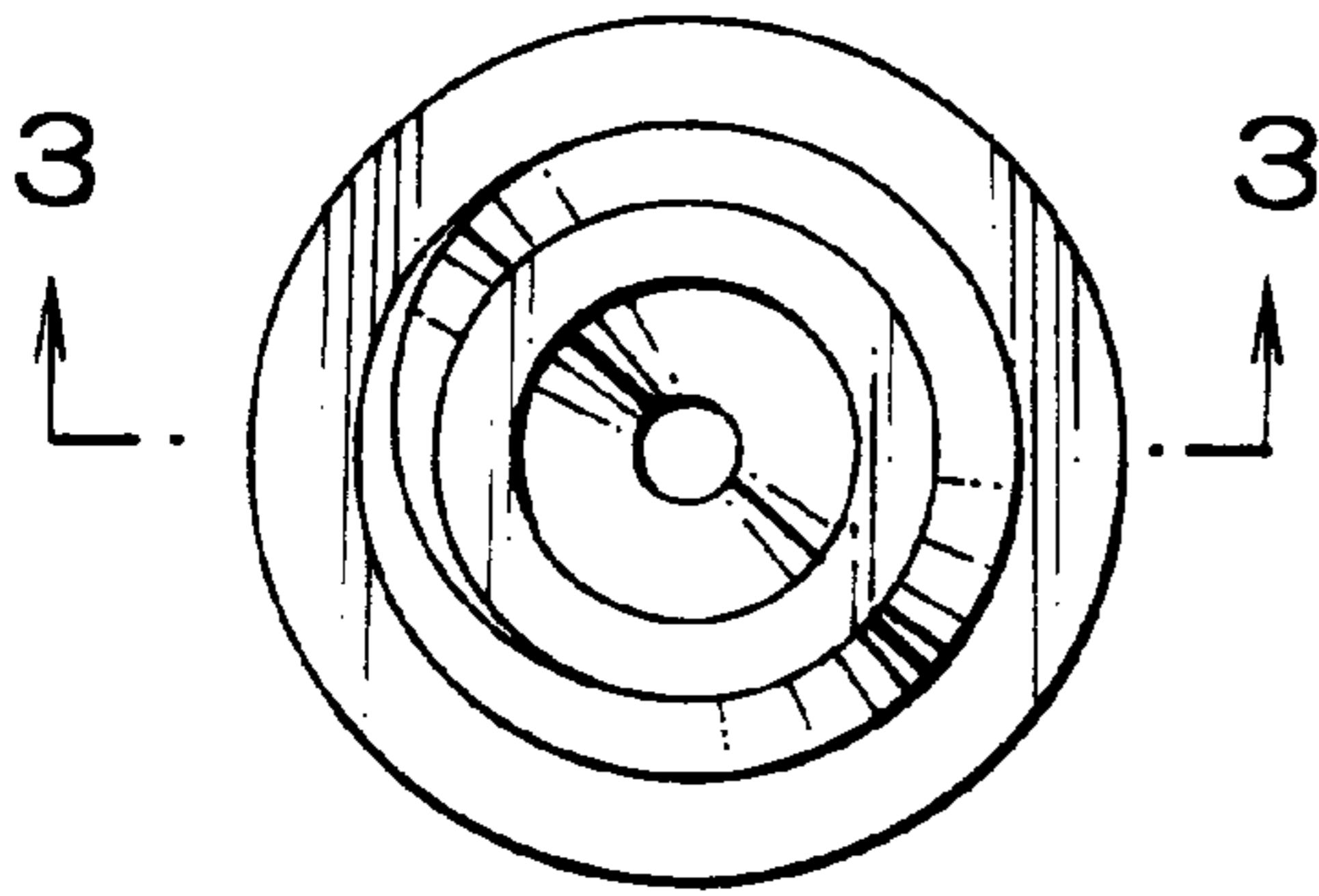

FIG. 23

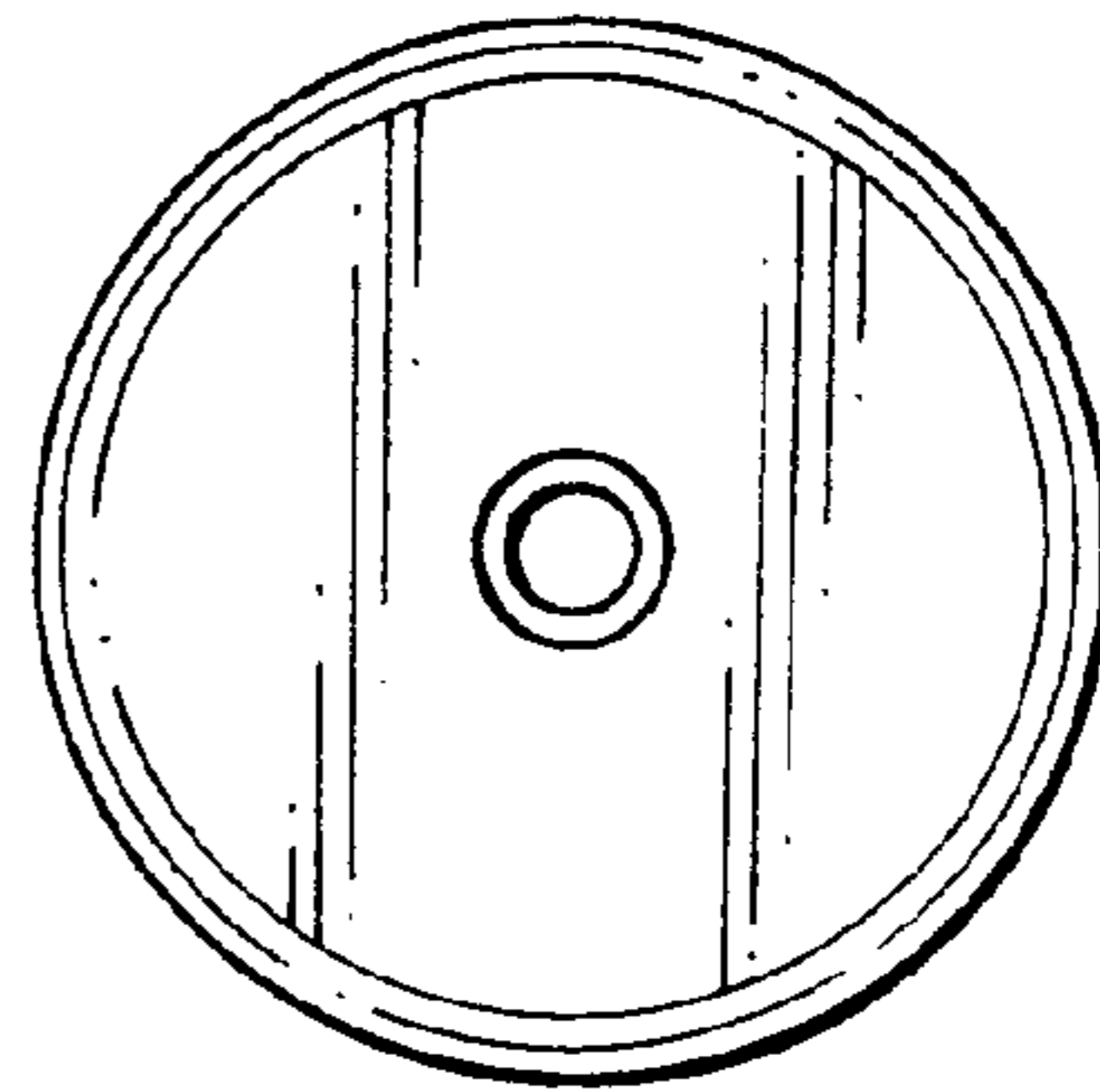

FIG. 24

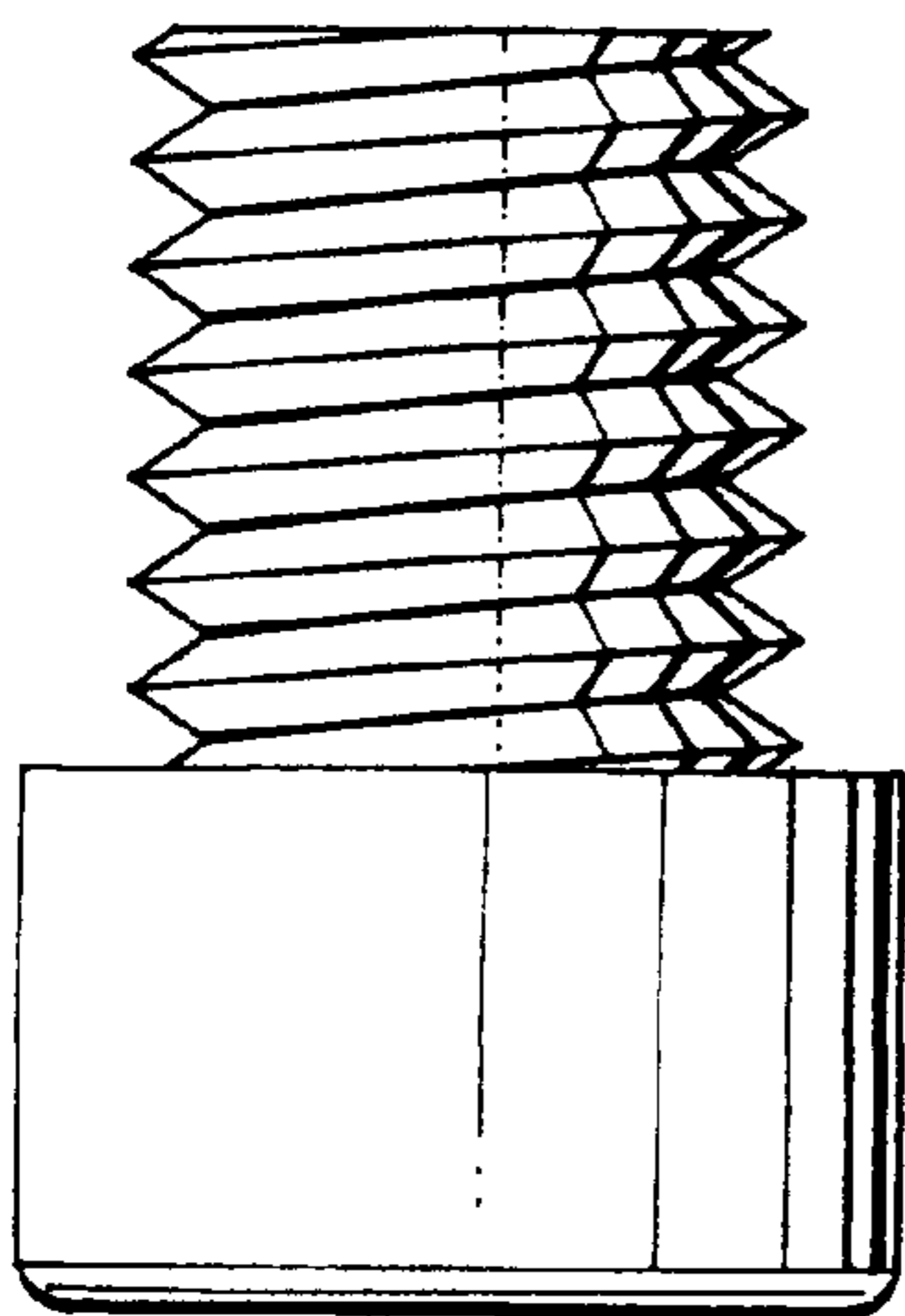

FIG. 25

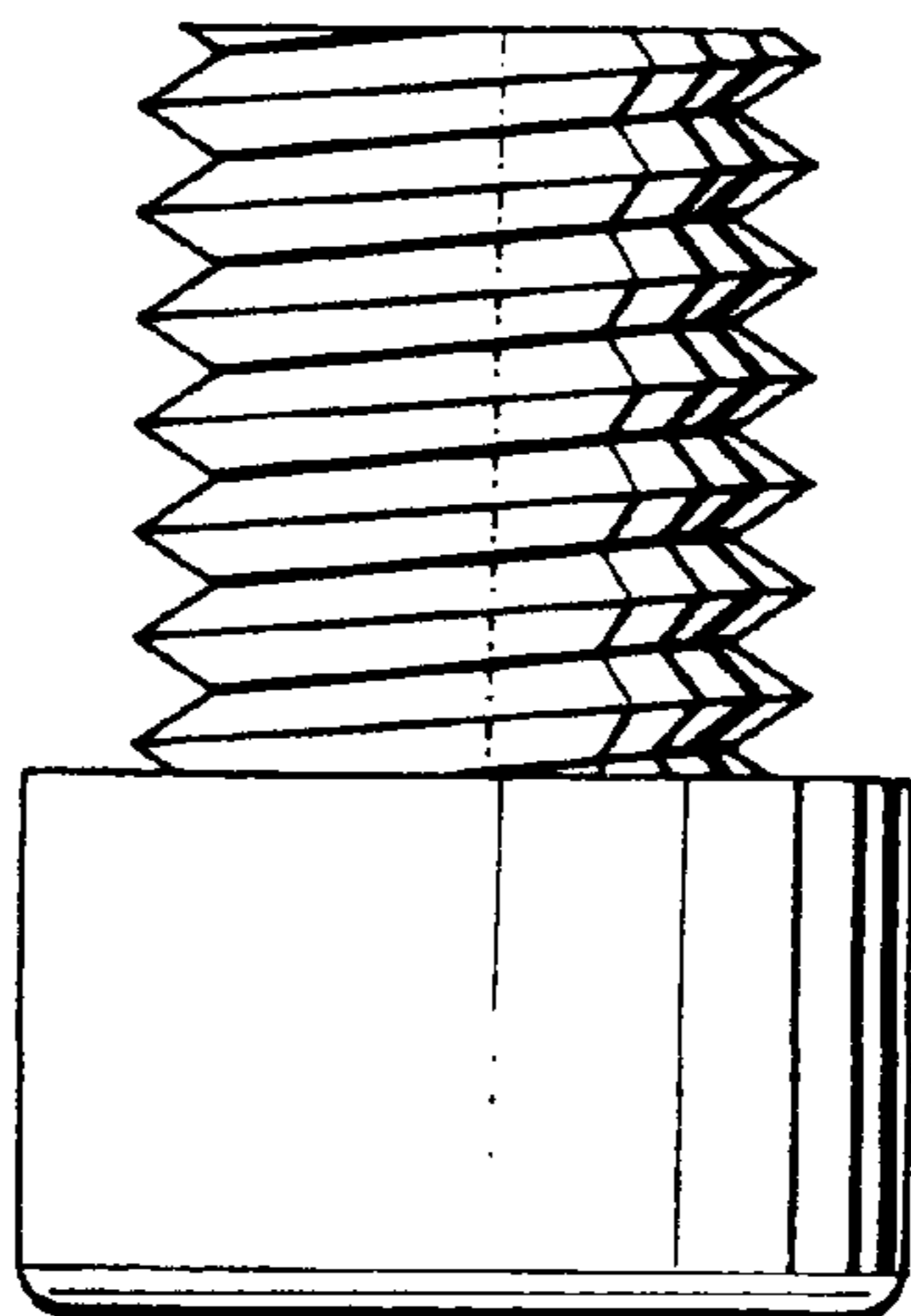

FIG. 26

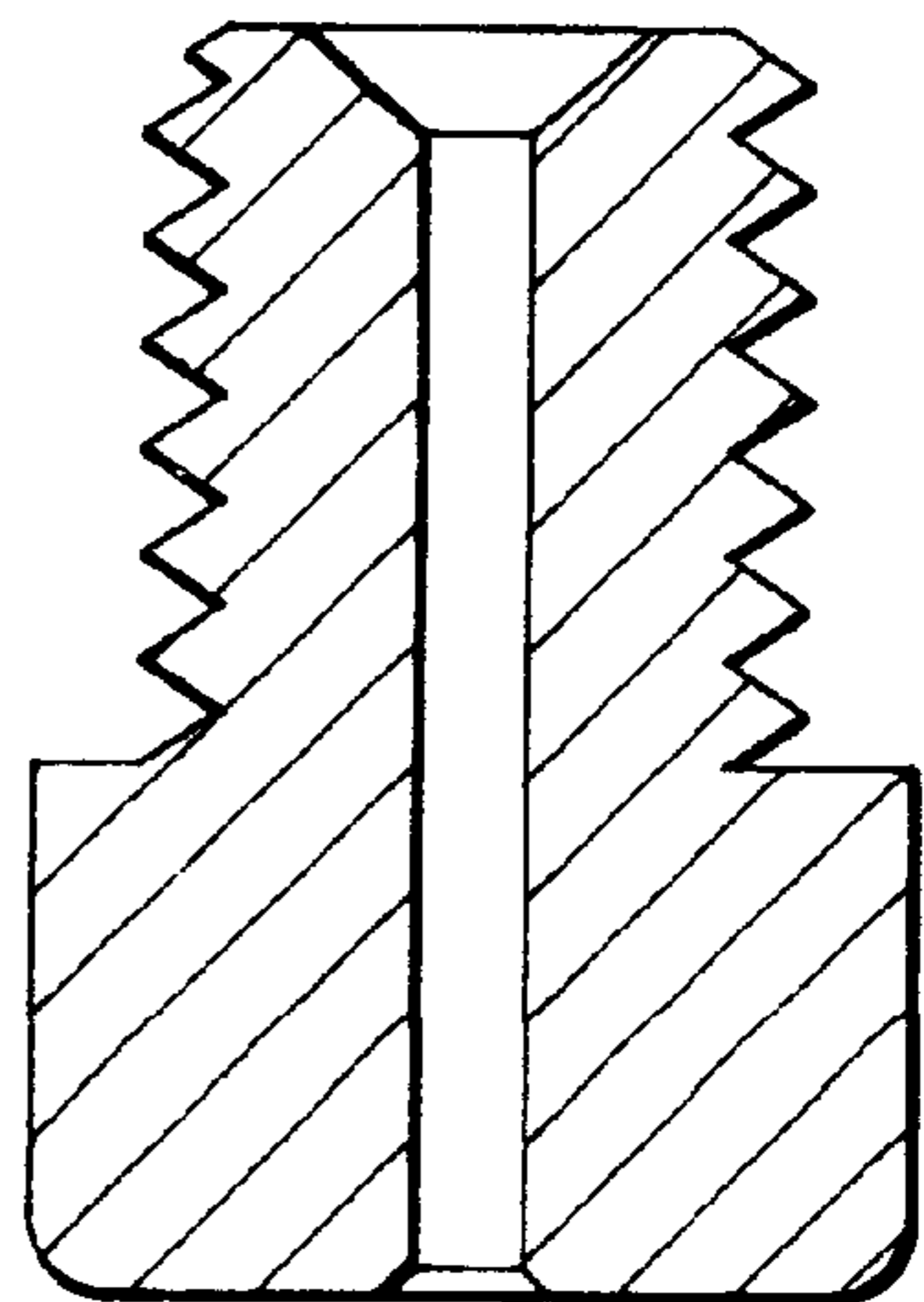

FIG. 27



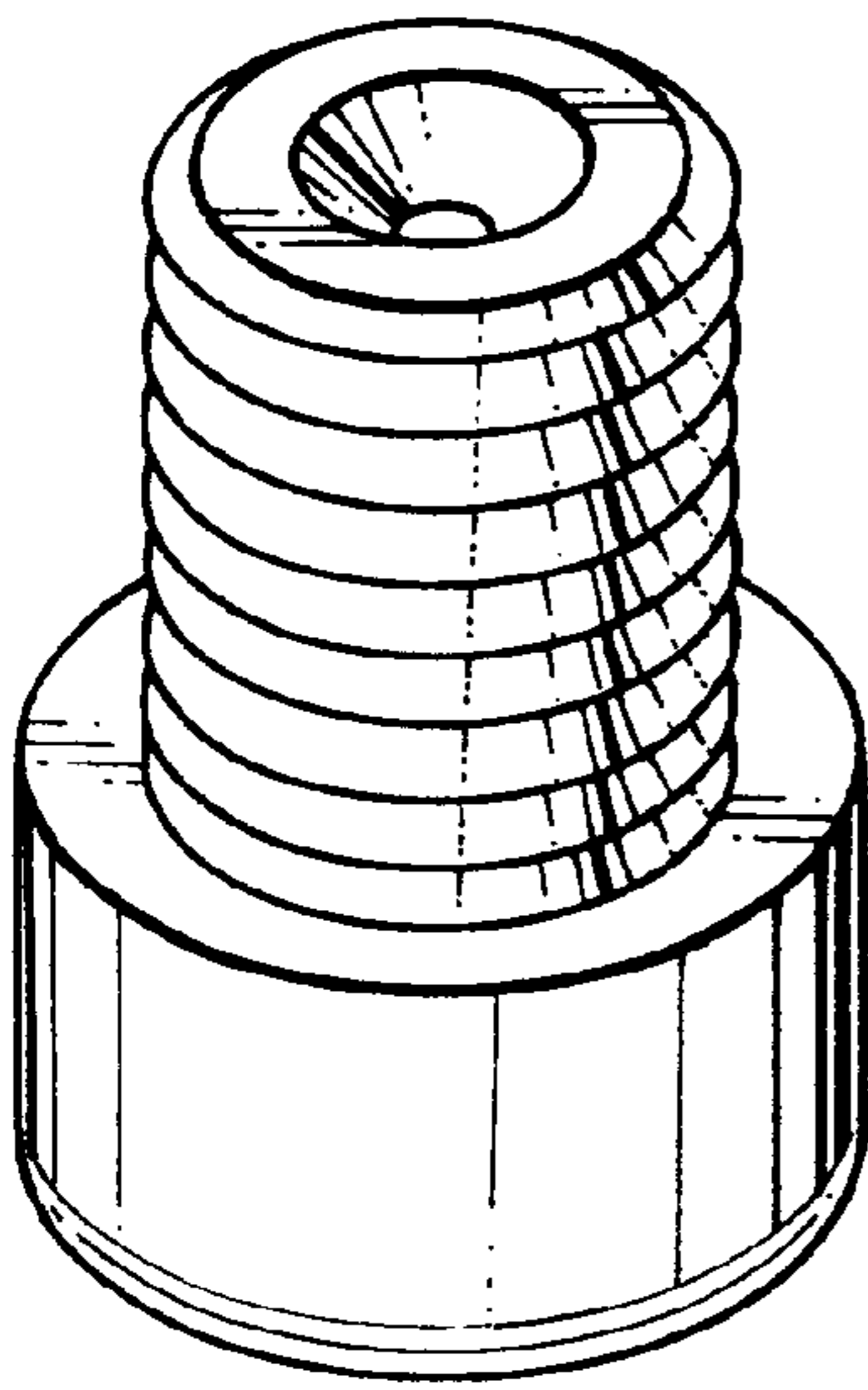

FIG. 28

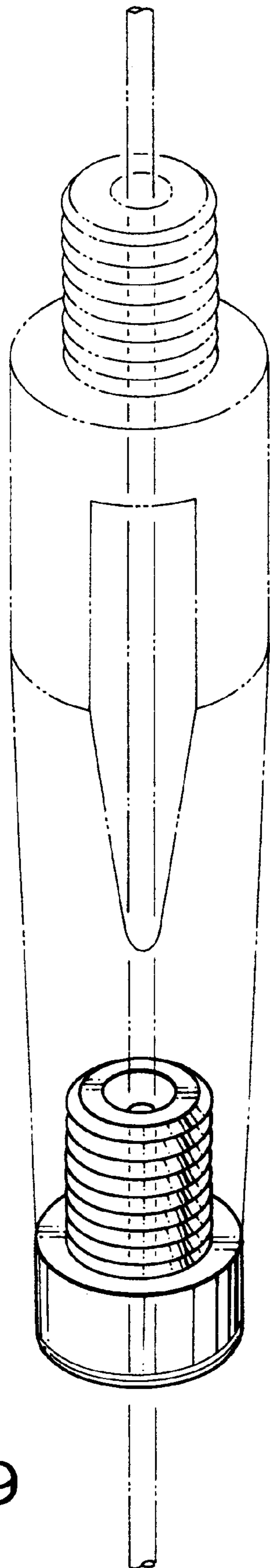

FIG. 29

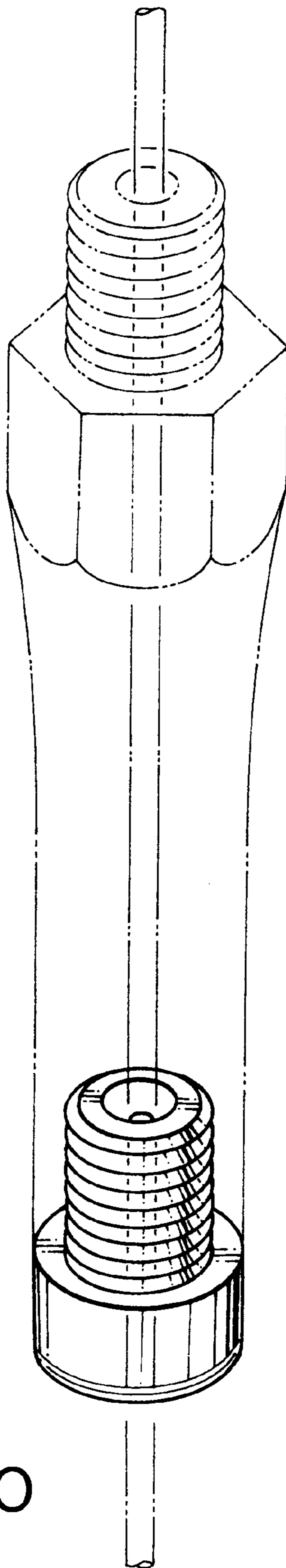

FIG. 30