



US00D409072S

# United States Patent [19] Clavin

[11] **Patent Number: Des. 409,072**

[45] **Date of Patent: \*\*May 4, 1999**

[54] **LATCH HANDLE ASSEMBLY**

[75] Inventor: **Timothy J. Clavin**, Corona, Calif.

[73] Assignee: **Hartwell Corporation**, Placentia, Calif.

[\*\*] Term: **14 Years**

[21] Appl. No.: **29/078,007**

[22] Filed: **Oct. 14, 1997**

[51] **LOC (6) Cl. .... 08-06**

[52] **U.S. Cl. .... D8/301; D8/308; D8/353**

[58] **Field of Search .... D8/301, 302, 308,  
D8/353; 16/110 R; 292/336.3, DIG. 68,  
DIG. 46**

[56] **References Cited**

**U.S. PATENT DOCUMENTS**

1,766,193	6/1930	Schmitz et al. ....	292/DIG. 68
2,022,853	12/1935	Geiselhart ....	292/DIG. 46
2,605,648	8/1952	Sanderlin et al. ....	292/336.3

**OTHER PUBLICATIONS**

Machine Design, Jan. 11, 1990 p. 177.  
1991 Catalog, Eberhard Industrial and Vehicular Hardware,  
pp. 112-114, 116-118.

*Primary Examiner*—B. J. Bullock  
*Attorney, Agent, or Firm*—Pretty, Schroeder & Poplawski

[57] **CLAIM**

The ornamental design for a latch handle assembly, as shown and described.

**DESCRIPTION**

FIG. 1 is a perspective view of the latch handle assembly of the invention, taken from the lower left;

FIG. 2 is a front view of the latch handle assembly of FIG. 1;

FIG. 3 is a right side view thereof;

FIG. 4 is a left view thereof;

FIG. 5 is a top view thereof;

FIG. 6 is a bottom view thereof; and,

FIG. 7 is a back view thereof.

**1 Claim, 6 Drawing Sheets**

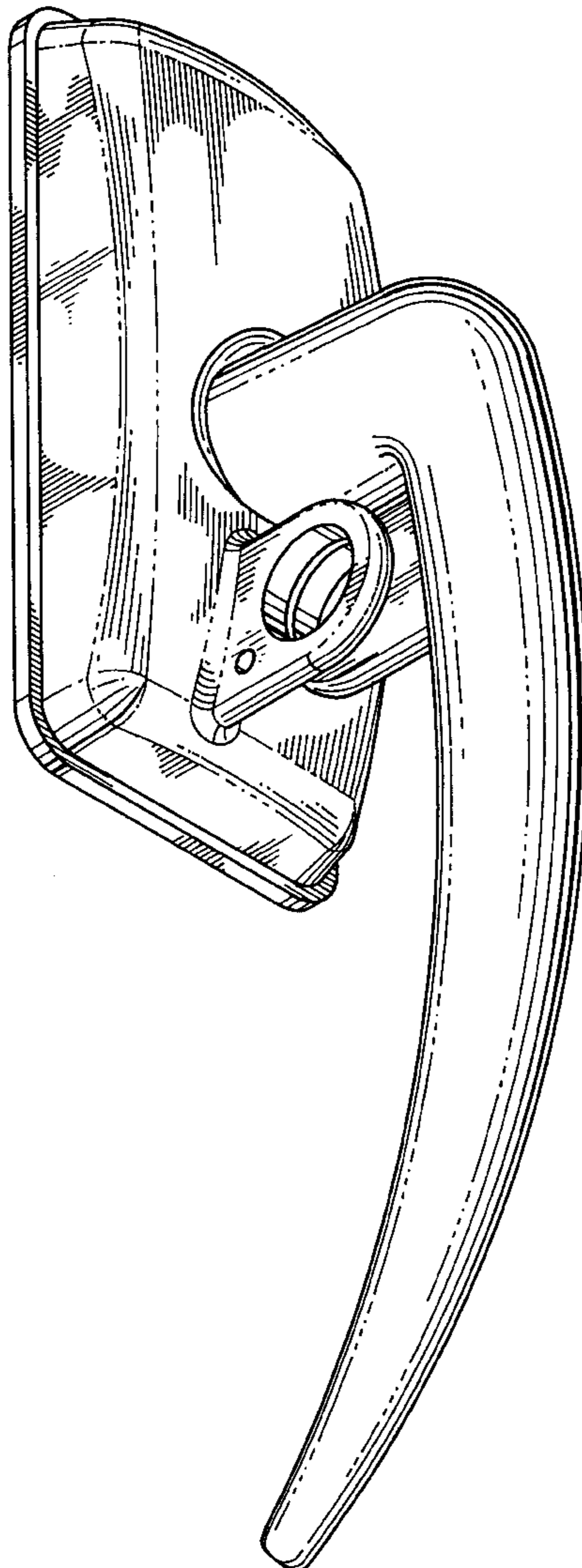

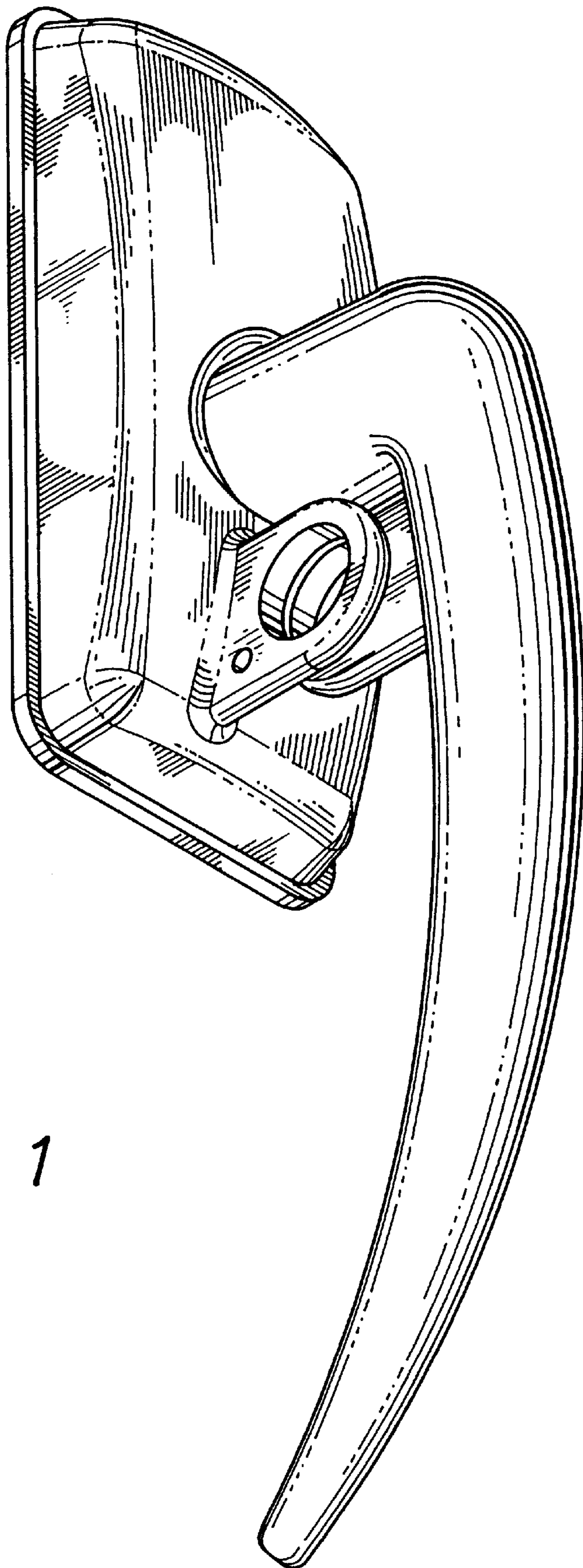
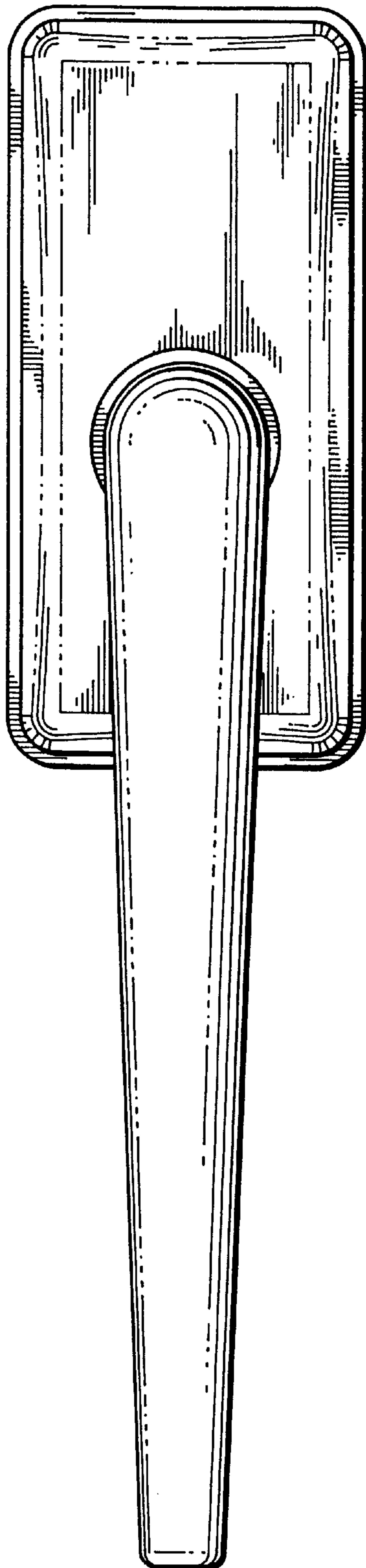

FIG. 1



*FIG. 2*

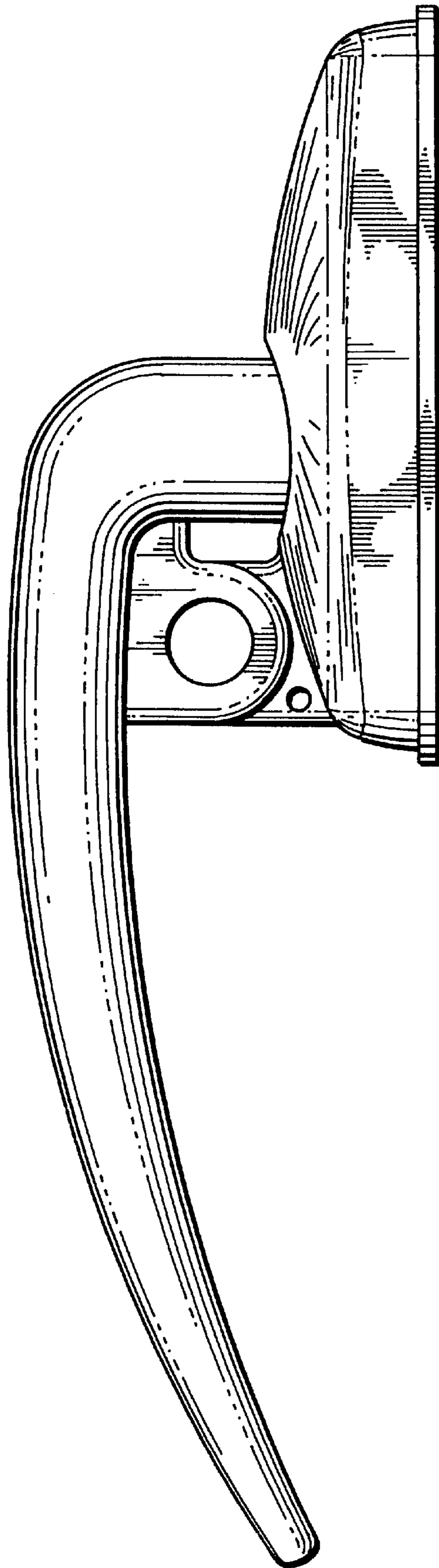

FIG. 3

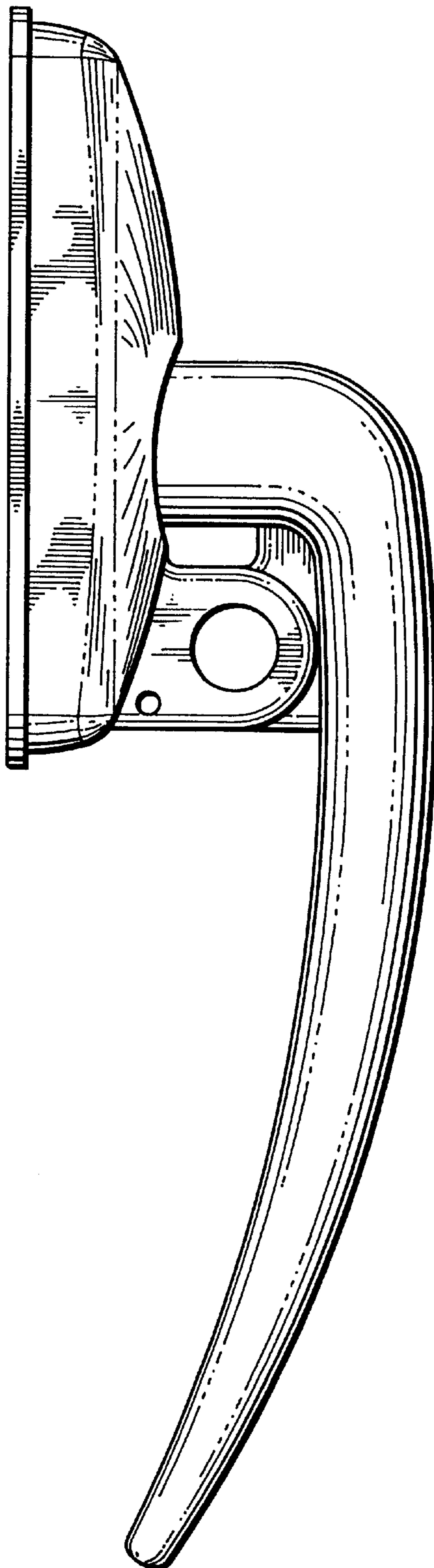

FIG. 4

FIG. 5

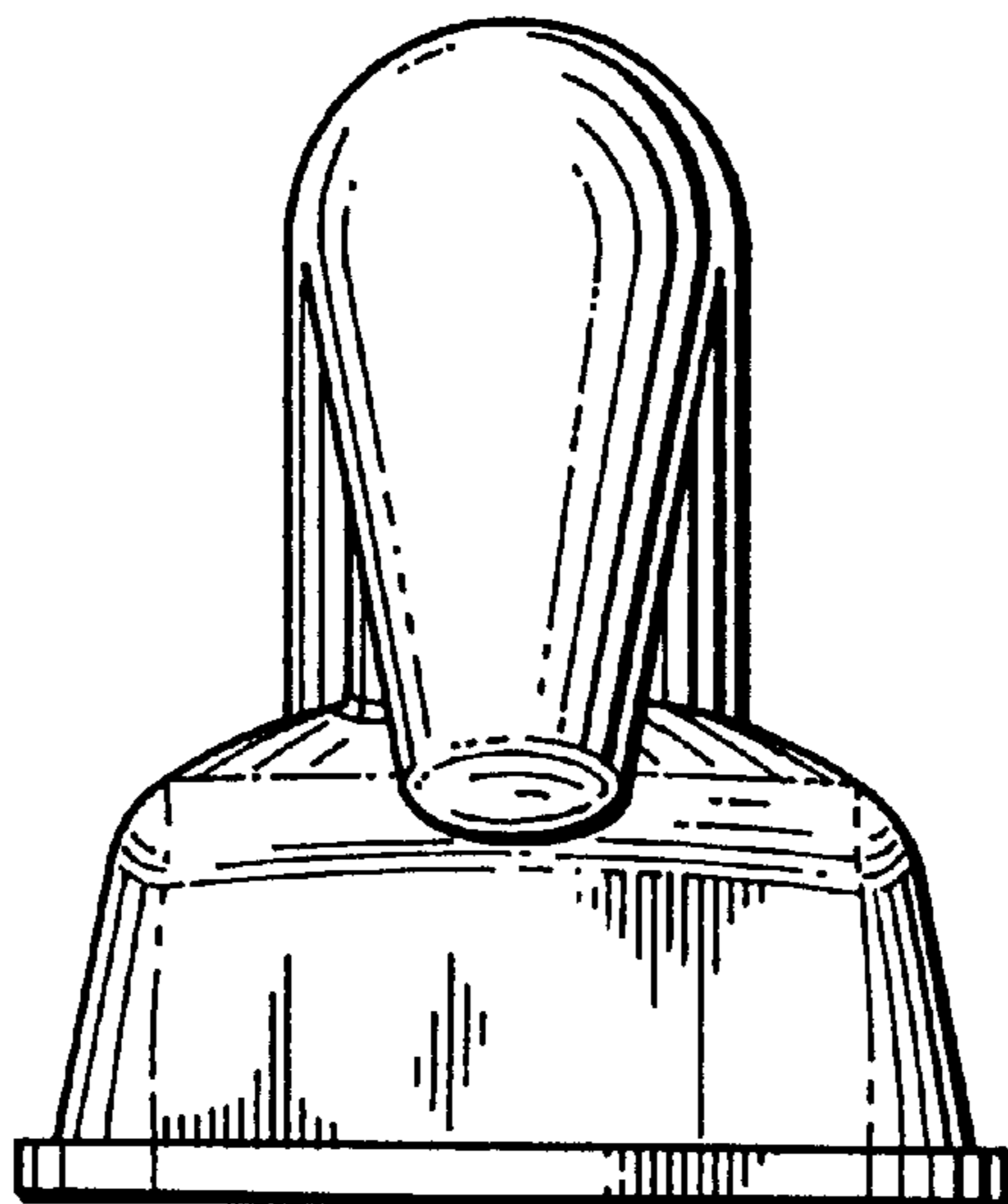
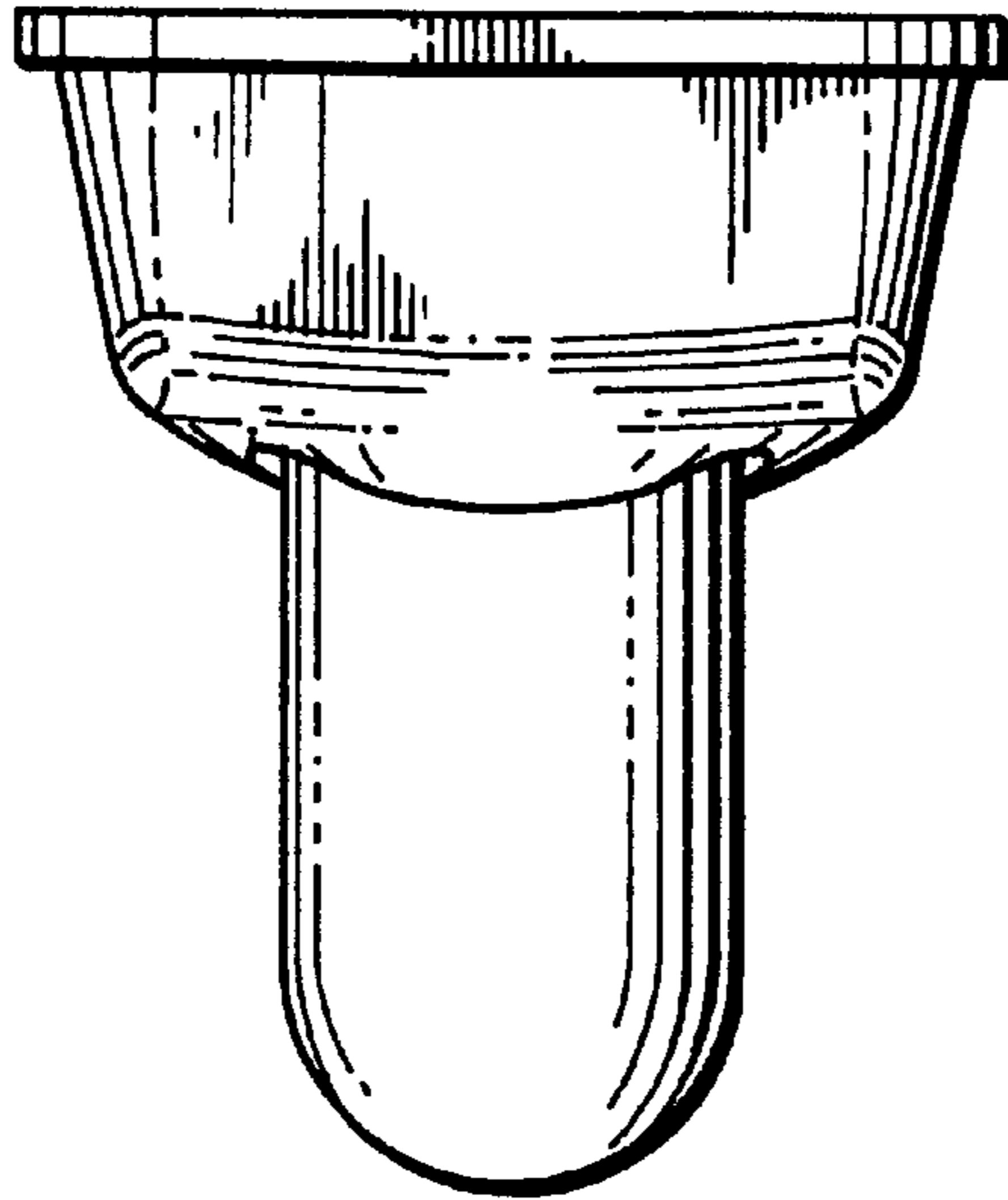

FIG. 6

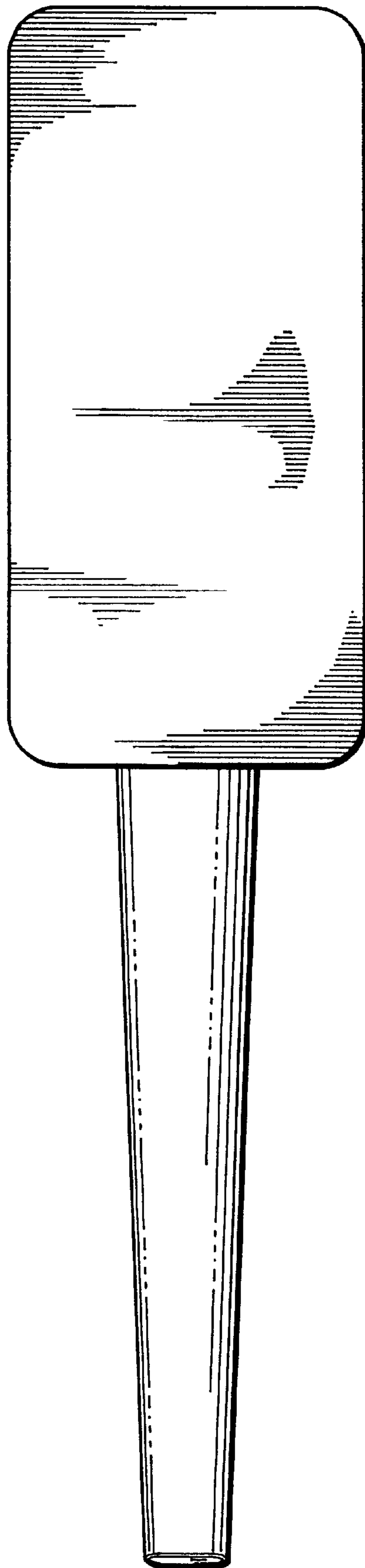

FIG. 7