



US00D408600S

United States Patent [19]

[11] Patent Number: Des. 408,600

Thur et al.

[45] Date of Patent: **Apr. 20, 1999

[54] VACUUM CLEANER

[75] Inventors: Charles J. Thur; Paul K. Foisy, both of Cleveland; Michael F. Wright, Cuyahoga Falls; David M. Brickner, Willoughby, all of Ohio

D. 354,379	1/1995	Shinozaki	D32/22
D. 358,236	5/1995	Kopco et al.	D32/22
4,621,390	11/1986	Hampton et al. .	
4,720,887	1/1988	Bosyj et al. .	
4,748,714	6/1988	Tschudy .	

OTHER PUBLICATIONS

[73] Assignee: Royal Appliance Mfg. Co., Cleveland, Ohio

Service Merchandise, Dec. 20, 1992, p. 36, "Dirt Devil Upright Vacuum Cleaners".

[**] Term: 14 Years

Service Merchandise, Dec. 20, 1992, p. 29, "Oxeck Ex Upright Vacuum Cleaners".

[21] Appl. No.: 29/033,429

Service Merchandise, Dec. 20, 1992, p. 38, "Eureka Upright Vacuum Cleaners".

[22] Filed: Jan. 12, 1995

Whirlpool CVR 2000 High Speed Upright.

[51] LOC (6) CL 15-05

Primary Examiner—Ruth McInroy

[52] U.S. Cl. D32/22

Attorney, Agent, or Firm—Fay, Sharpe, Beall, Fagan, Minnich & McKee

[58] Field of Search D32/21-22; 15/320-321, 15/335, 347, 350-353, 361

[57] CLAIM

[56] References Cited

The ornamental design for a vacuum cleaner, as shown.

U.S. PATENT DOCUMENTS

DESCRIPTION

- D. 207,069 2/1967 Kieft .
- D. 229,335 11/1973 Wareham et al. .
- D. 293,727 1/1988 Wareham et al. .
- D. 293,728 1/1988 Ohhira et al. D32/22
- D. 301,648 6/1989 Kieft .
- D. 301,784 6/1989 Petralia et al. D32/22
- D. 305,169 12/1989 Essex et al. .
- D. 309,806 8/1990 Chieda et al. D32/22
- D. 313,681 1/1991 McKnight .
- D. 314,260 1/1991 Lee D32/22
- D. 319,517 8/1991 Sovis et al. D32/22
- D. 339,433 9/1993 Stein et al. D32/22
- D. 346,052 4/1994 Saunders et al. .
- D. 346,469 4/1994 Furcron et al. D32/22

FIG. 1 is a right side elevational view of a vacuum cleaner showing our new design;
 FIG. 2 is a top plan view thereof;
 FIG. 3 is left side elevational view thereof;
 FIG. 4 is a bottom plan view thereof;
 FIG. 5 is a front elevational view thereof;
 FIG. 6 is a rear elevational view thereof; and,
 FIG. 7 is front perspective view thereof.
 The details shown in broken lines in FIGS. 5-7 are shown for illustrative purposes only and form no part of the claimed design.

1 Claim, 6 Drawing Sheets

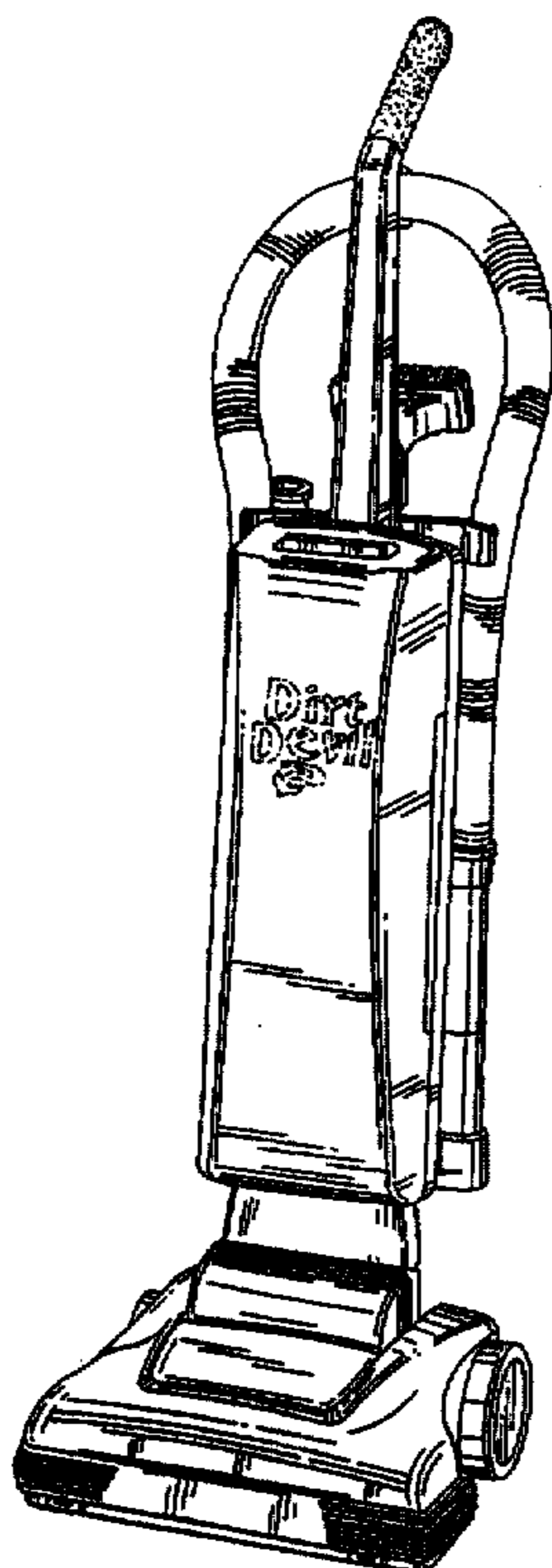

FIG. 1

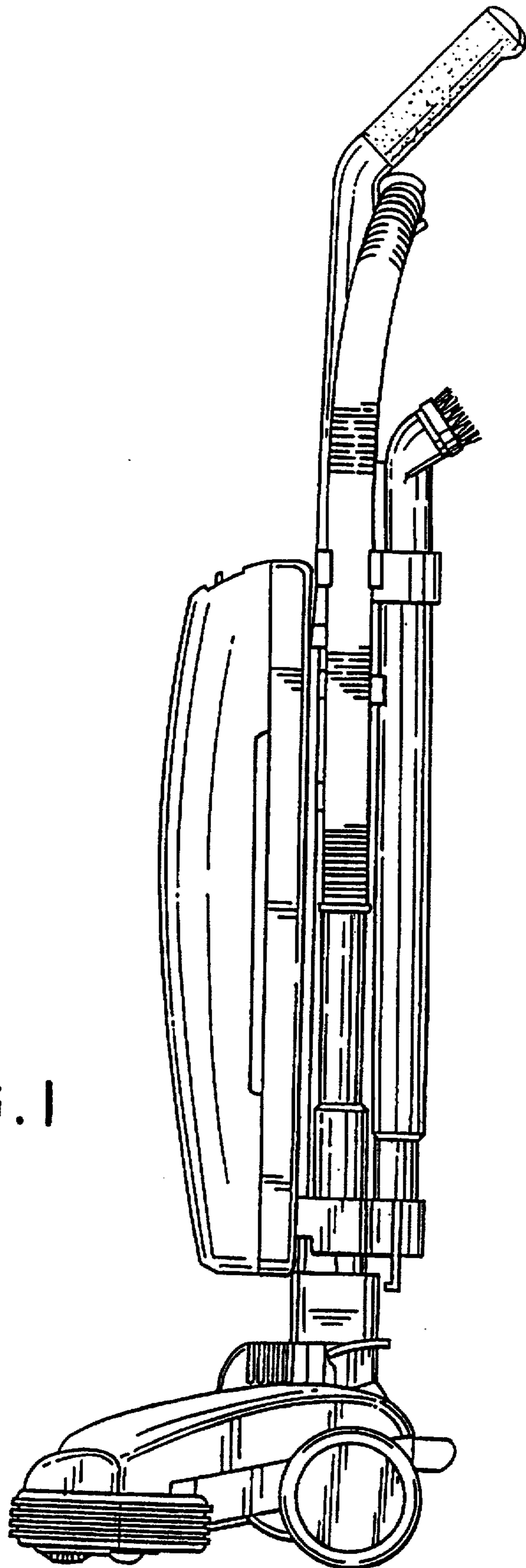

FIG. 2

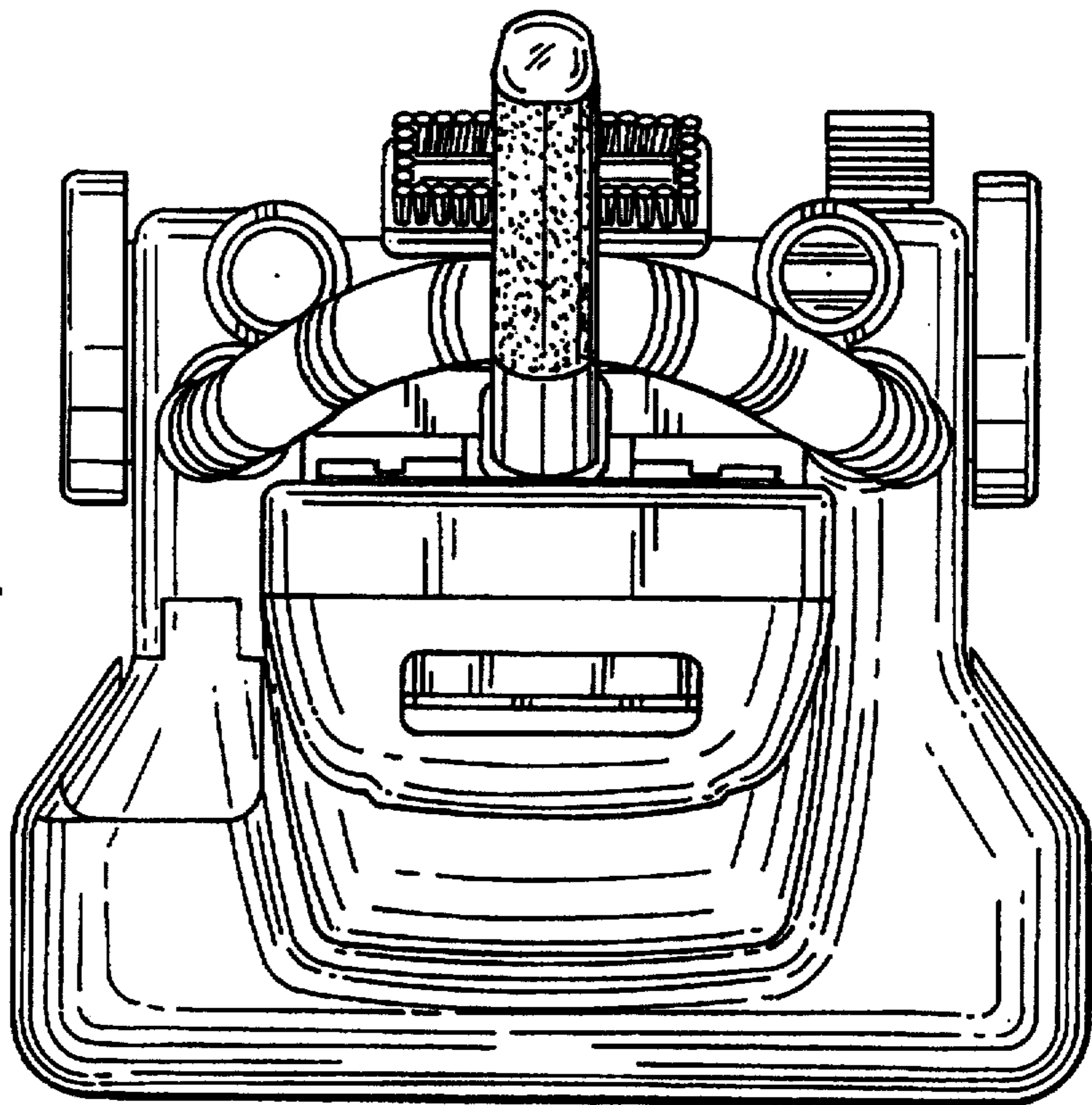
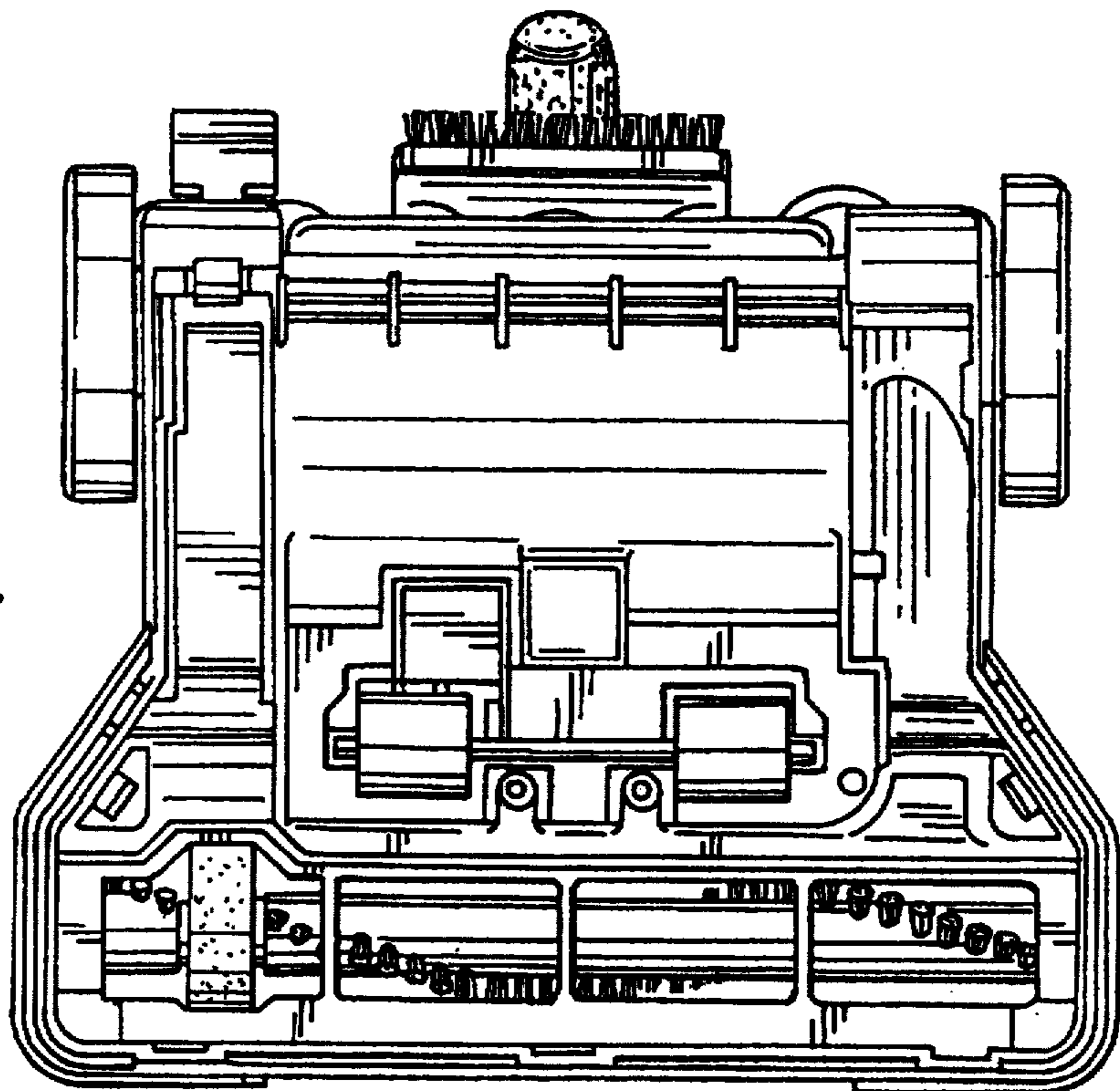

FIG. 4



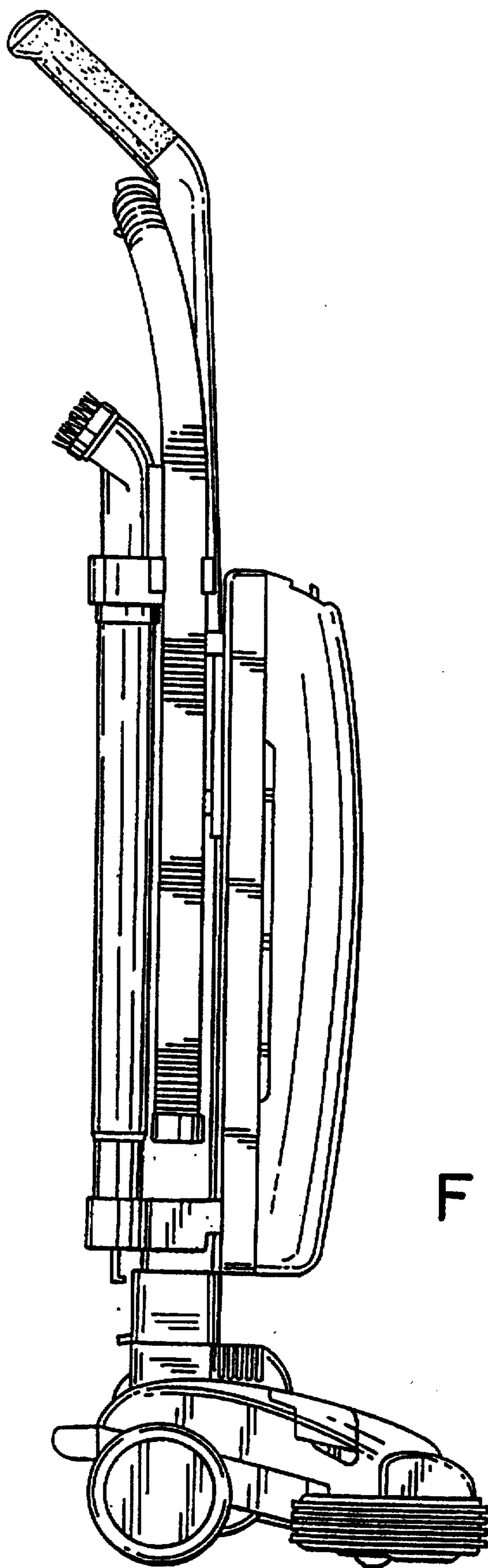

FIG. 3



FIG. 5

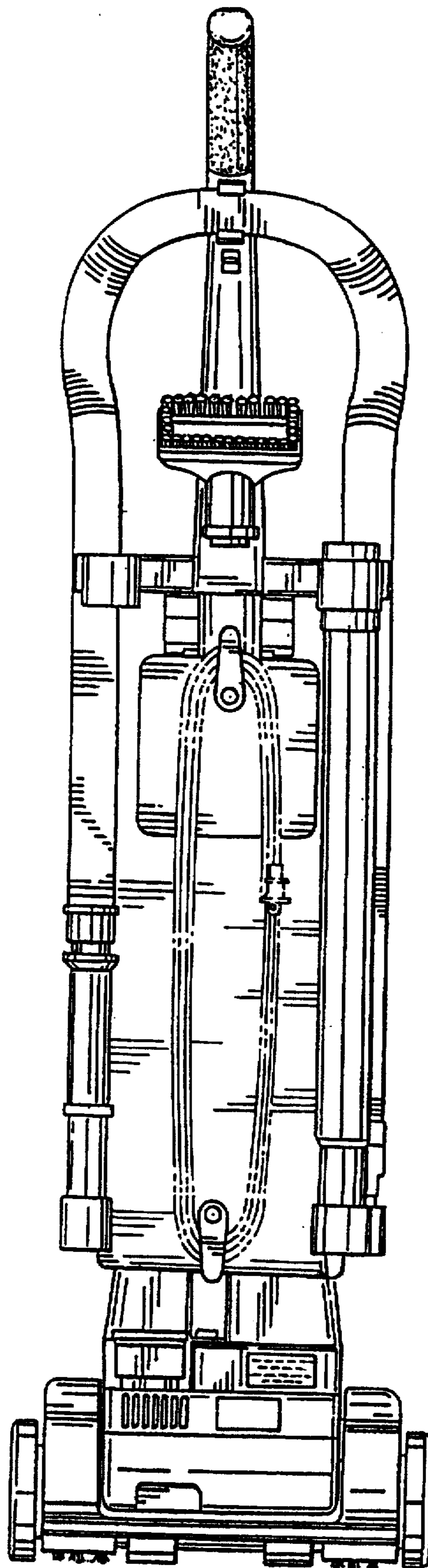

FIG. 6

FIG. 7

