



US00D408340S

United States Patent [19]
Phillips

[11] **Patent Number: Des. 408,340**
[45] **Date of Patent: **Apr. 20, 1999**

[54] **SAFETY BACKUP MIRROR**

[76] **Inventor: Edward J. Phillips, 915 E. 68th,
Kansas City, Mo. 64131**

[**] **Term: 14 Years**

[21] **Appl. No.: 29/086,321**

[22] **Filed: Apr. 9, 1998**

Related U.S. Application Data

[62] **Division of application No. 29/067,454, Mar. 7, 1997, Pat.
No. Des. 395,266.**

[51] **LOC (6) Cl. 12-16**

[52] **U.S. Cl. D12/187**

[58] **Field of Search D12/187-189;
359/838, 871-876, 850; 248/475.1, 477,
479**

[56] **References Cited**

U.S. PATENT DOCUMENTS

D. 204,188	3/1966	Lee	D12/187
D. 213,772	4/1969	Wallace et al.	D12/187
D. 241,532	9/1976	Bourassa	D12/187
D. 259,716	6/1981	Watanabe	D12/187
D. 259,915	7/1981	Watanabe	D12/189
4,664,489	5/1987	Kams	359/850

Primary Examiner—Ralf Seifert
Attorney, Agent, or Firm—Chase & Yakimo, L.C.

[57] **CLAIM**

The ornamental design for a safety backup mirror, as shown and described.

DESCRIPTION

FIG. 1 is a first perspective view of a safety backup mirror showing my new design;

FIG. 2 is a second perspective view thereof;

FIG. 3 is a front elevational view thereof oriented with the mirror in a horizontal plane;

FIG. 4 is a top plan view thereof, the mirror being fully shown and other components being broken away and partially shown;

FIG. 5 is a bottom view thereof, the mirror being fully shown and other components being broken away and partially shown; and,

FIG. 6 is an end elevational view thereof, the mirror being fully shown and other components being broken away and partially shown.

The broken lines, in FIGS. 1 and 2, showing a vehicle mount are for illustrative purposes only and form no part of the claimed design.

1 Claim, 2 Drawing Sheets

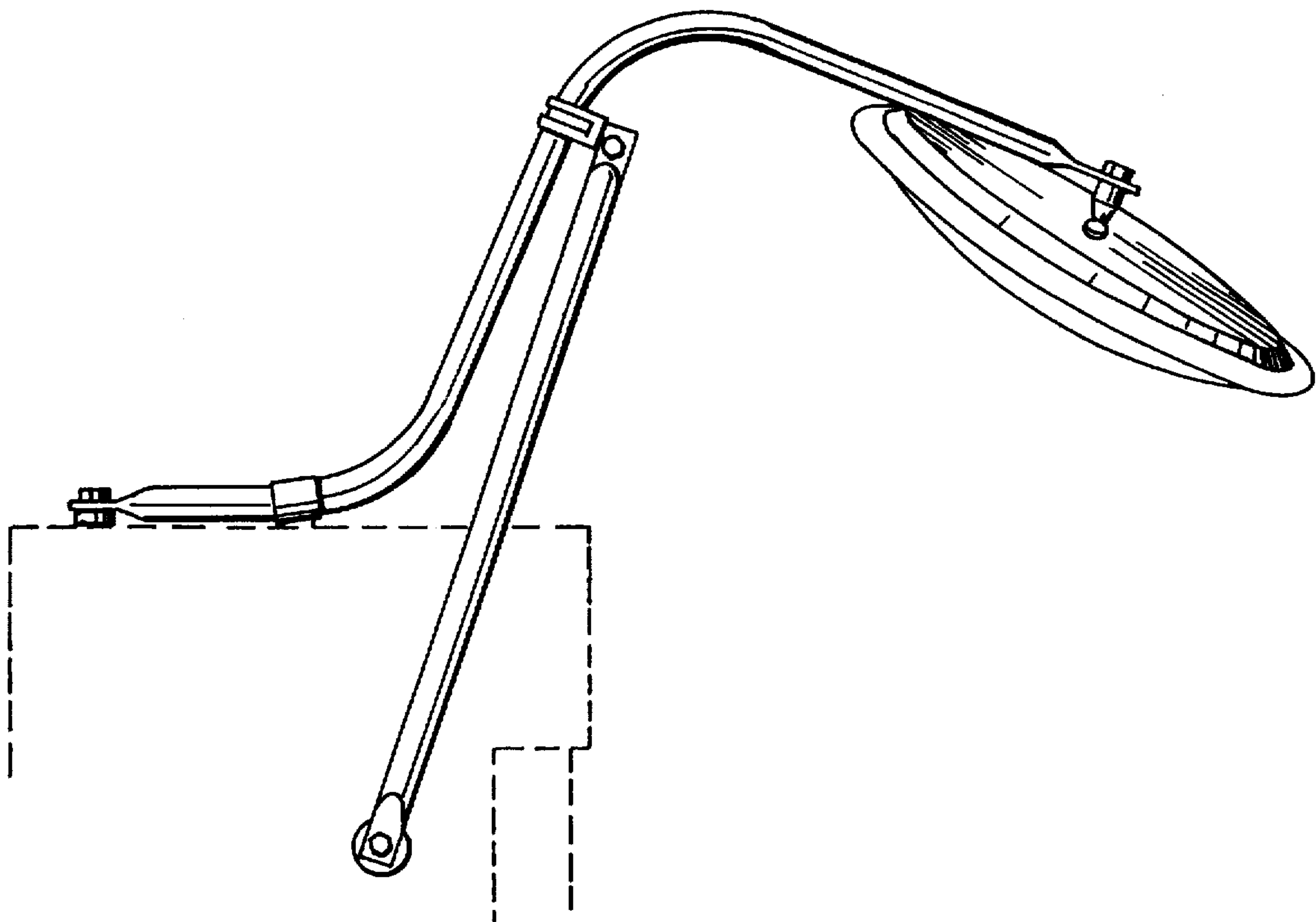

Fig. 1

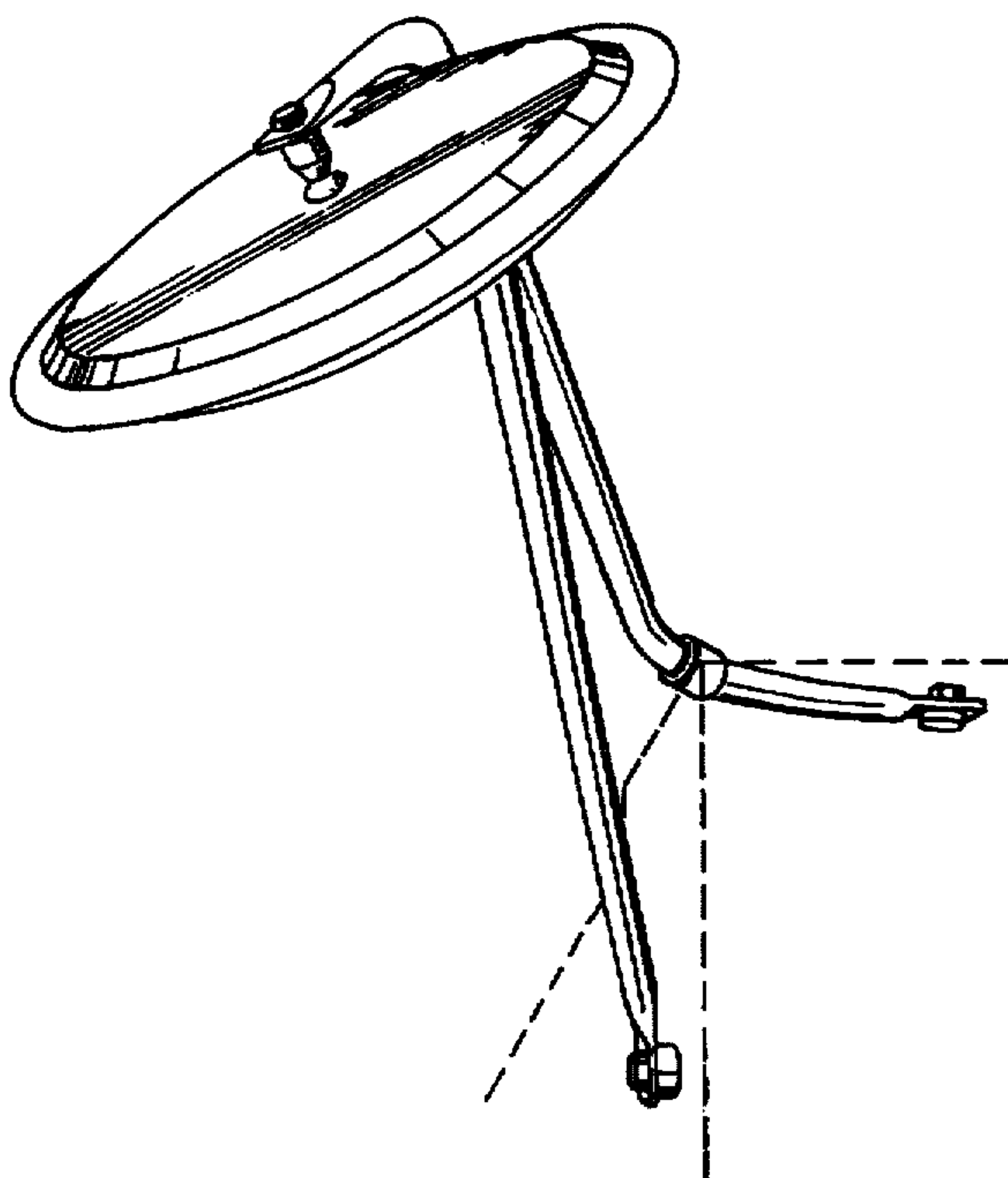
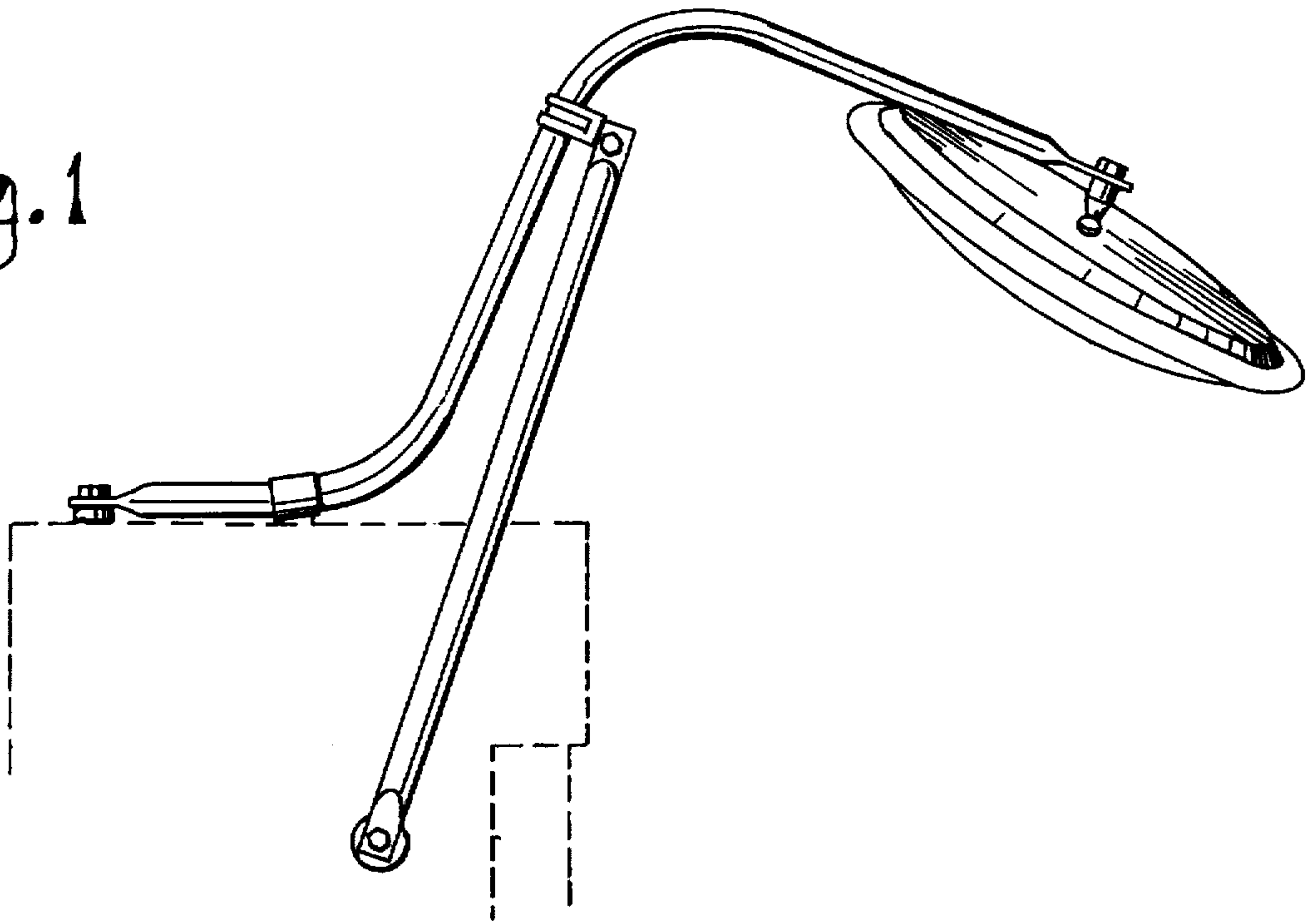

Fig. 2

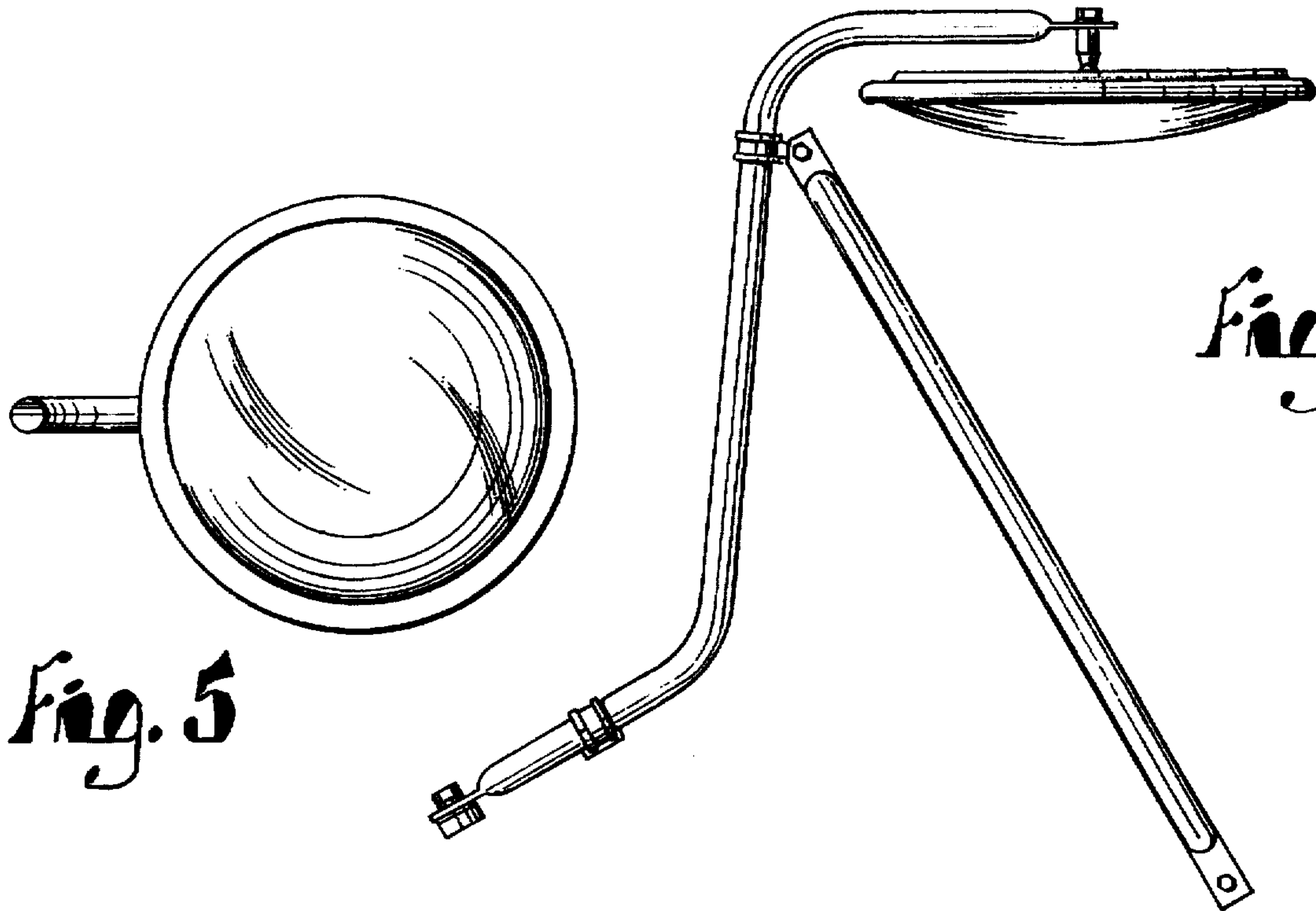

Fig. 3

Fig. 5

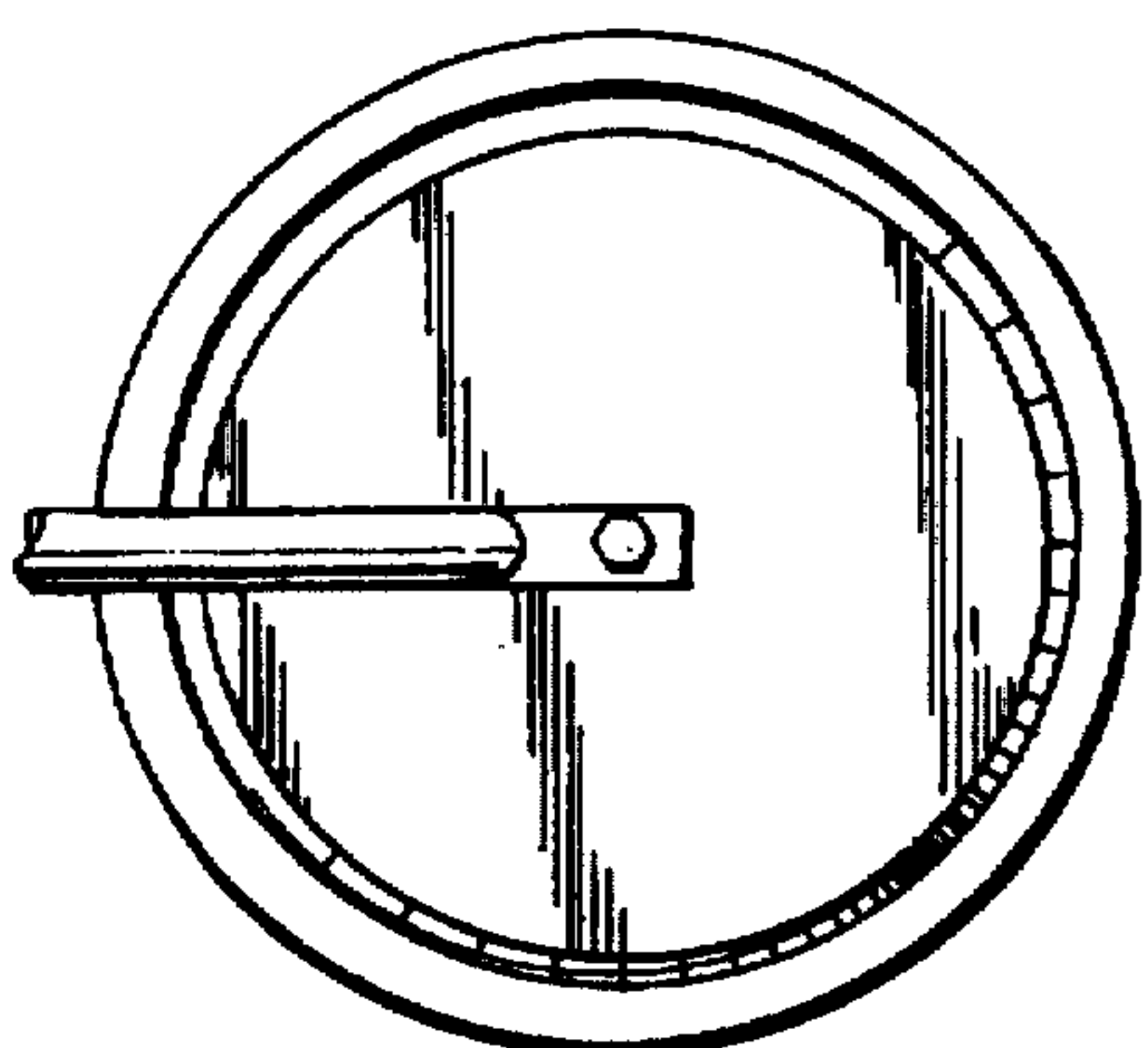

Fig. 4

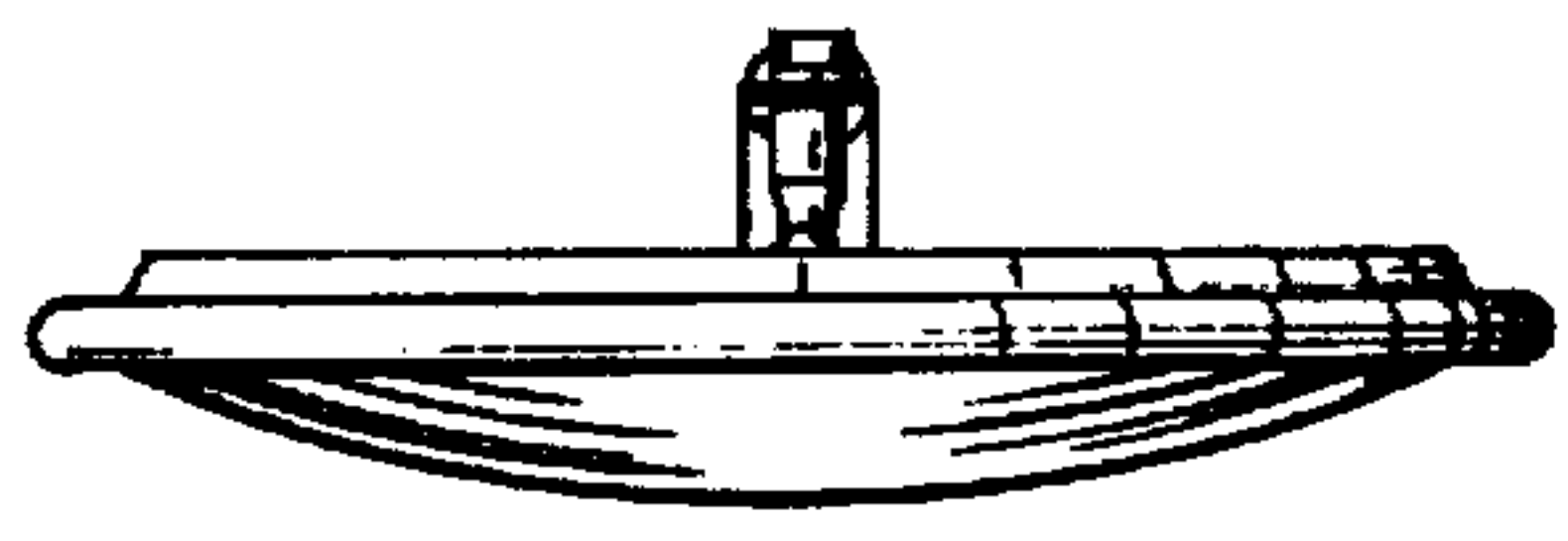

Fig. 6