



US00D407883S

# United States Patent [19]

Okerlund et al.

[11] **Patent Number:** **Des. 407,883**

[45] **Date of Patent:** **\*\*Apr. 6, 1999**

[54] **WINCH HOUSING**

2,913,224 11/1959 Uhlig ..... D34/33  
5,593,140 1/1997 Van Beers ..... 254/374

[75] Inventors: **Kawa-She-Quden Wm. Okerlund,**  
Wittenberg; **Thomas J. Rudasics,**  
Wausau, both of Wis.

*Primary Examiner*—Doris Clark  
*Attorney, Agent, or Firm*—Edgar A. Zarins; Malcolm L.  
Sutherland

[73] Assignee: **Fulton Performance Products, Inc.,**  
Mosinee, Wis.

## [57] **CLAIM**

[\*\*] Term: **14 Years**

The ornamental design for a winch housing, as shown and described.

[21] Appl. No.: **57,991**

## **DESCRIPTION**

[22] Filed: **Aug. 6, 1996**

FIG. 1 is a perspective view of a winch housing showing our new design;

[51] **LOC (6) Cl.** ..... **12-05**

FIG. 2 is a side elevational view thereof, the opposite side being a mirror image of the side shown;

[52] **U.S. Cl.** ..... **D34/33**

FIG. 3 is a front elevational view thereof;

[58] **Field of Search** ..... D34/33; 254/374,  
254/266, 371, 372; 242/601, 613.1, 613.2

FIG. 4 is a top plan view thereof;

FIG. 5 is a bottom plan view thereof; and,

FIG. 6 is a rear elevational view thereof.

The broken lines are for illustrative purposes only, and form no part of the claimed design.

## [56] **References Cited**

### U.S. PATENT DOCUMENTS

D. 330,962 11/1992 Cindy et al. .... D34/33  
D. 364,027 11/1995 Hung ..... D34/33

**1 Claim, 2 Drawing Sheets**

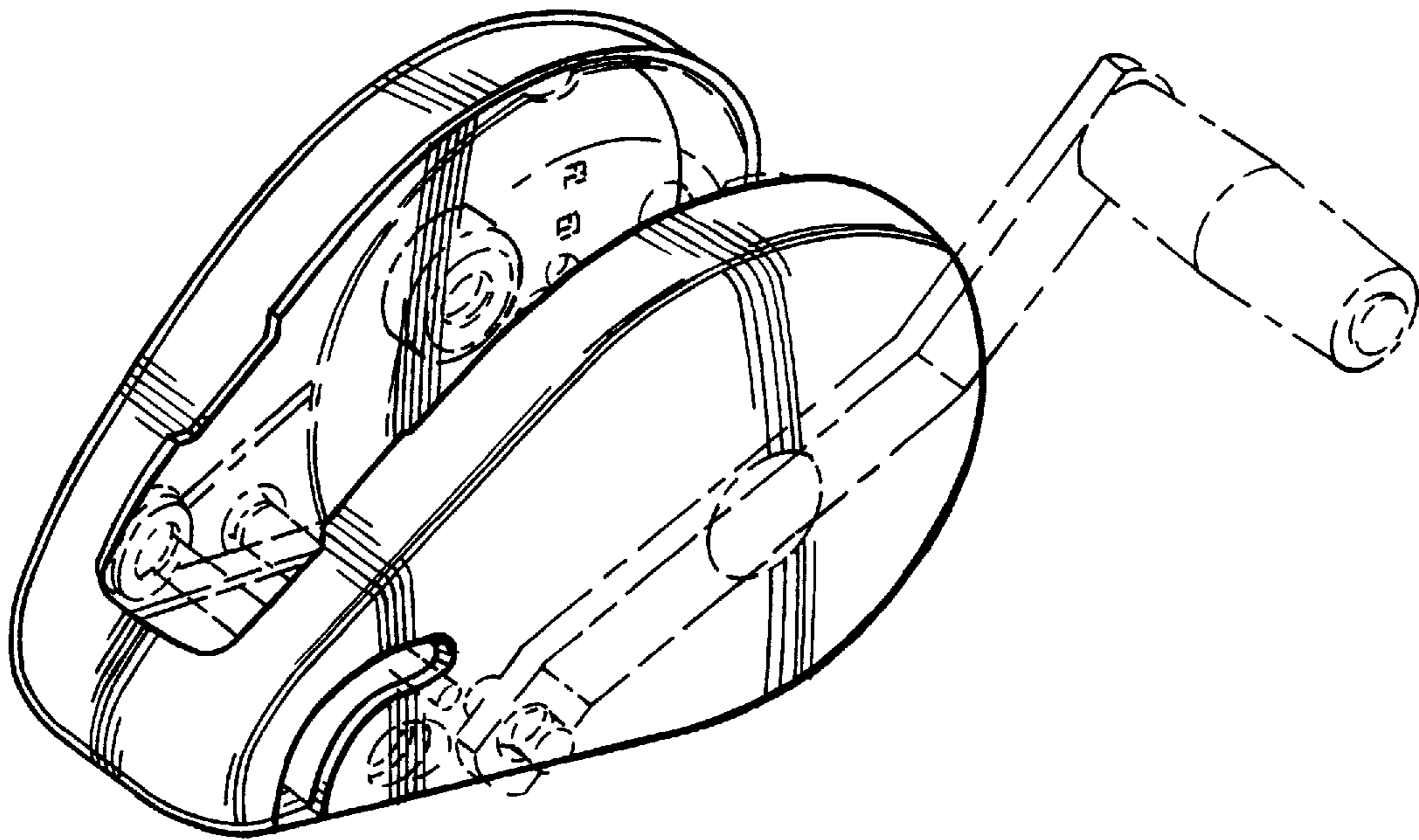

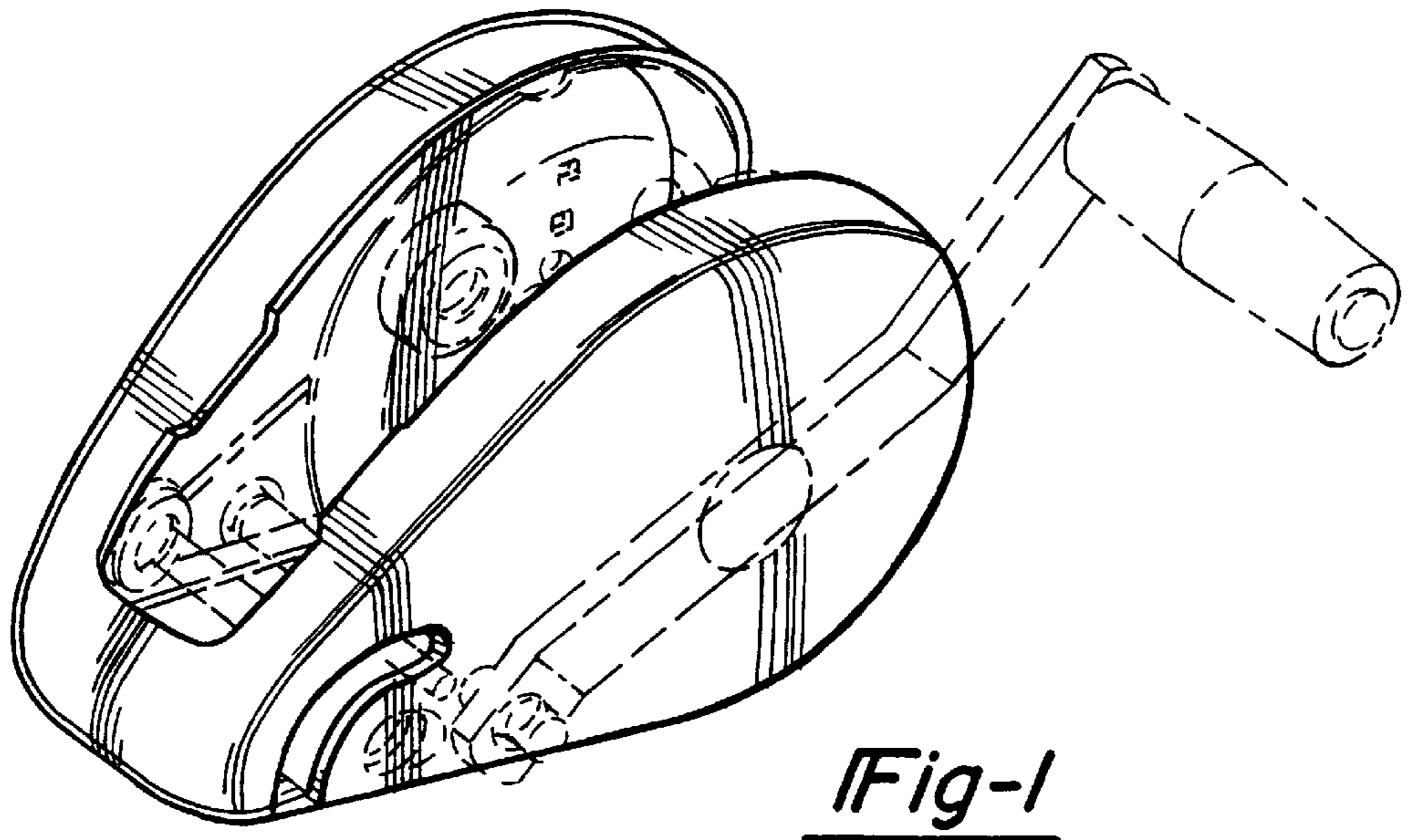

Fig-1

Fig-2

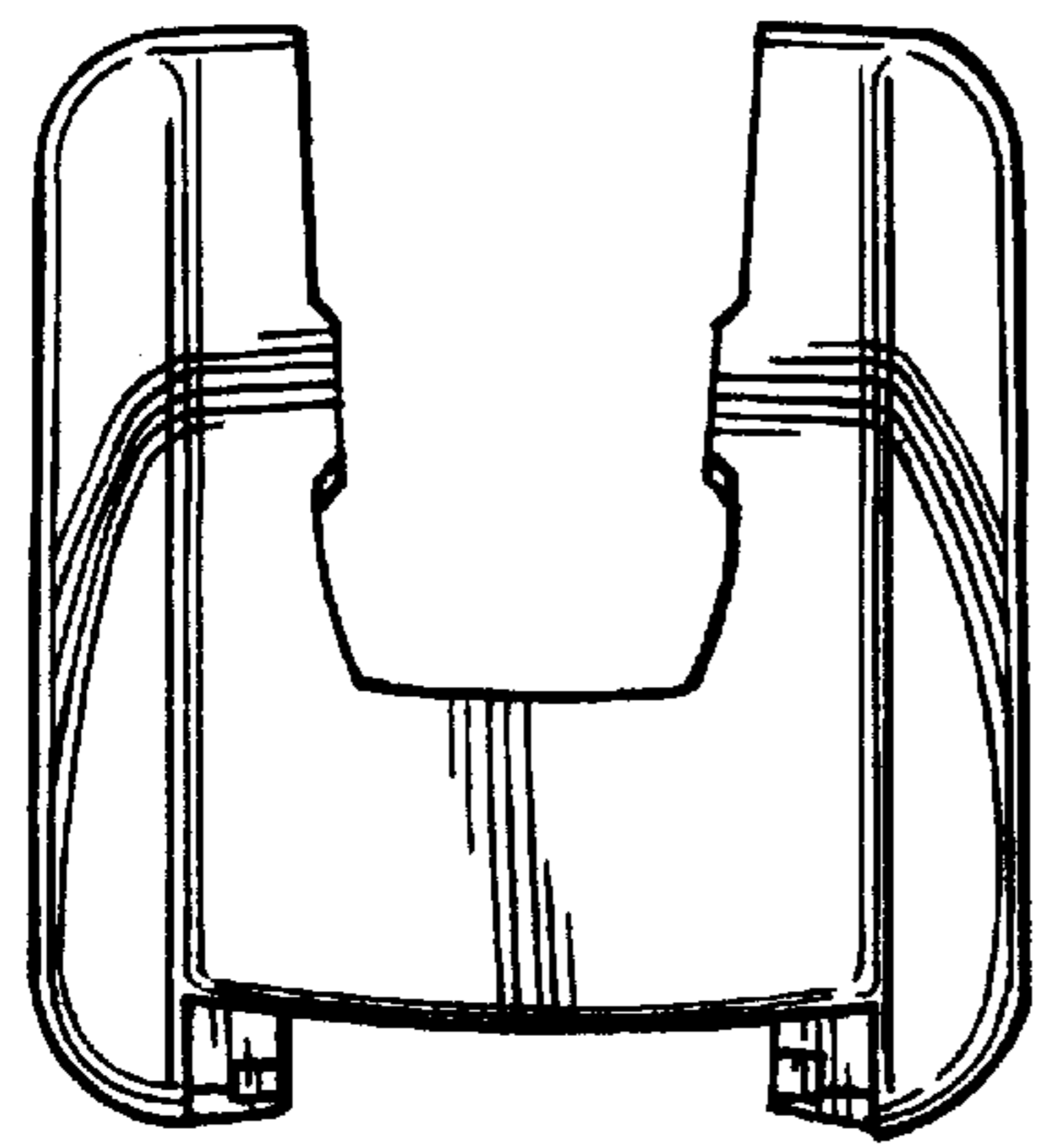
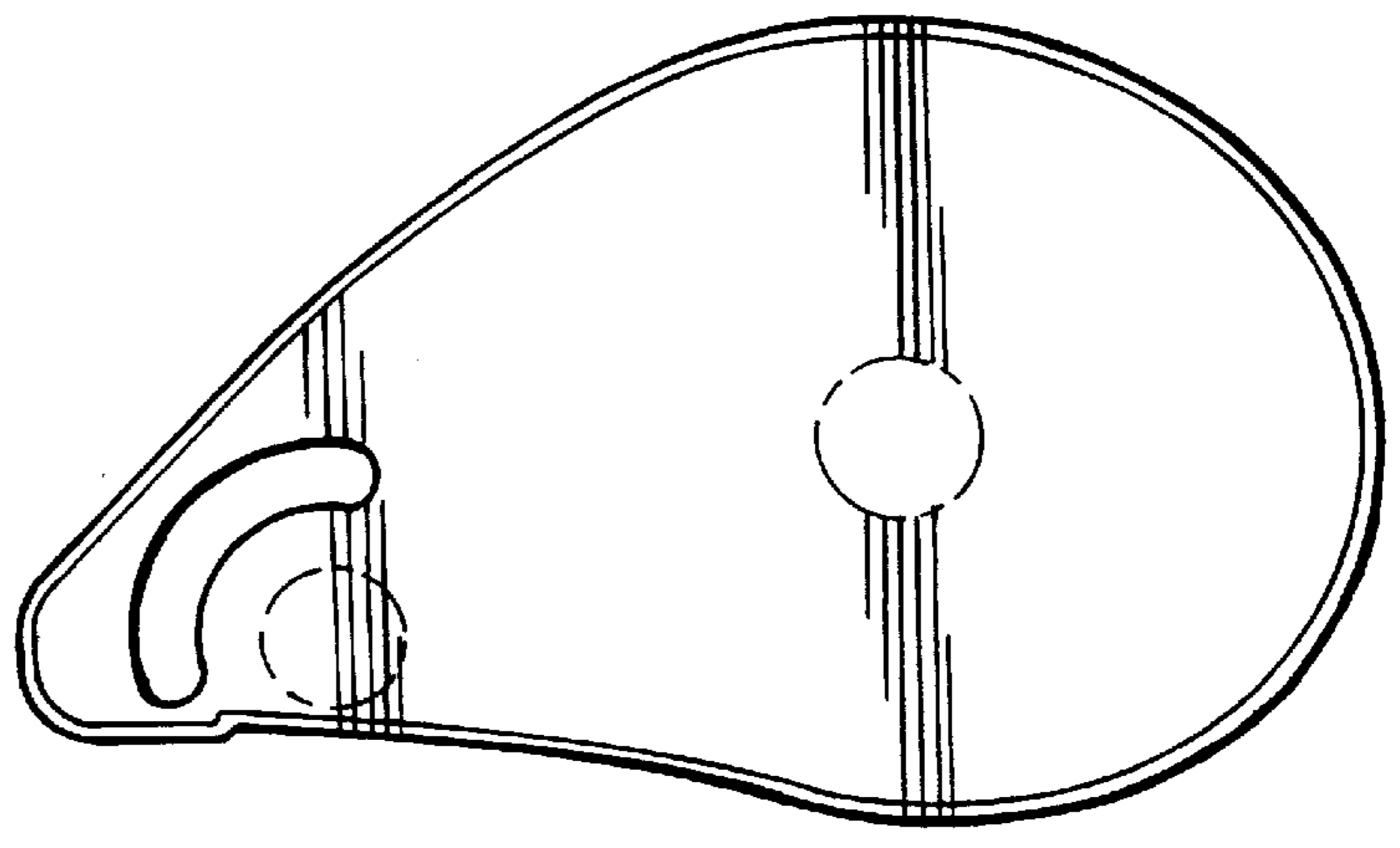

Fig-3

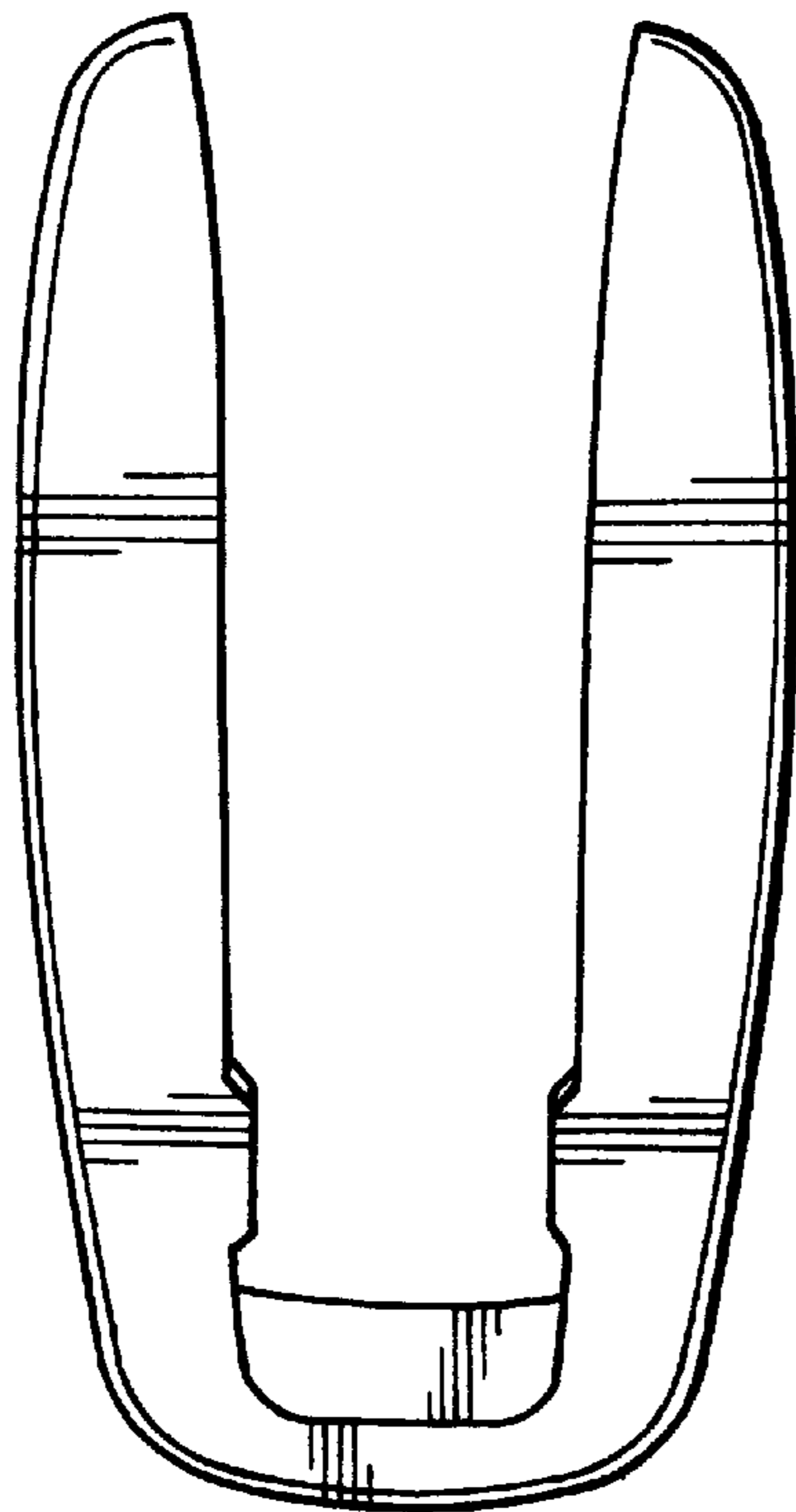

Fig-4

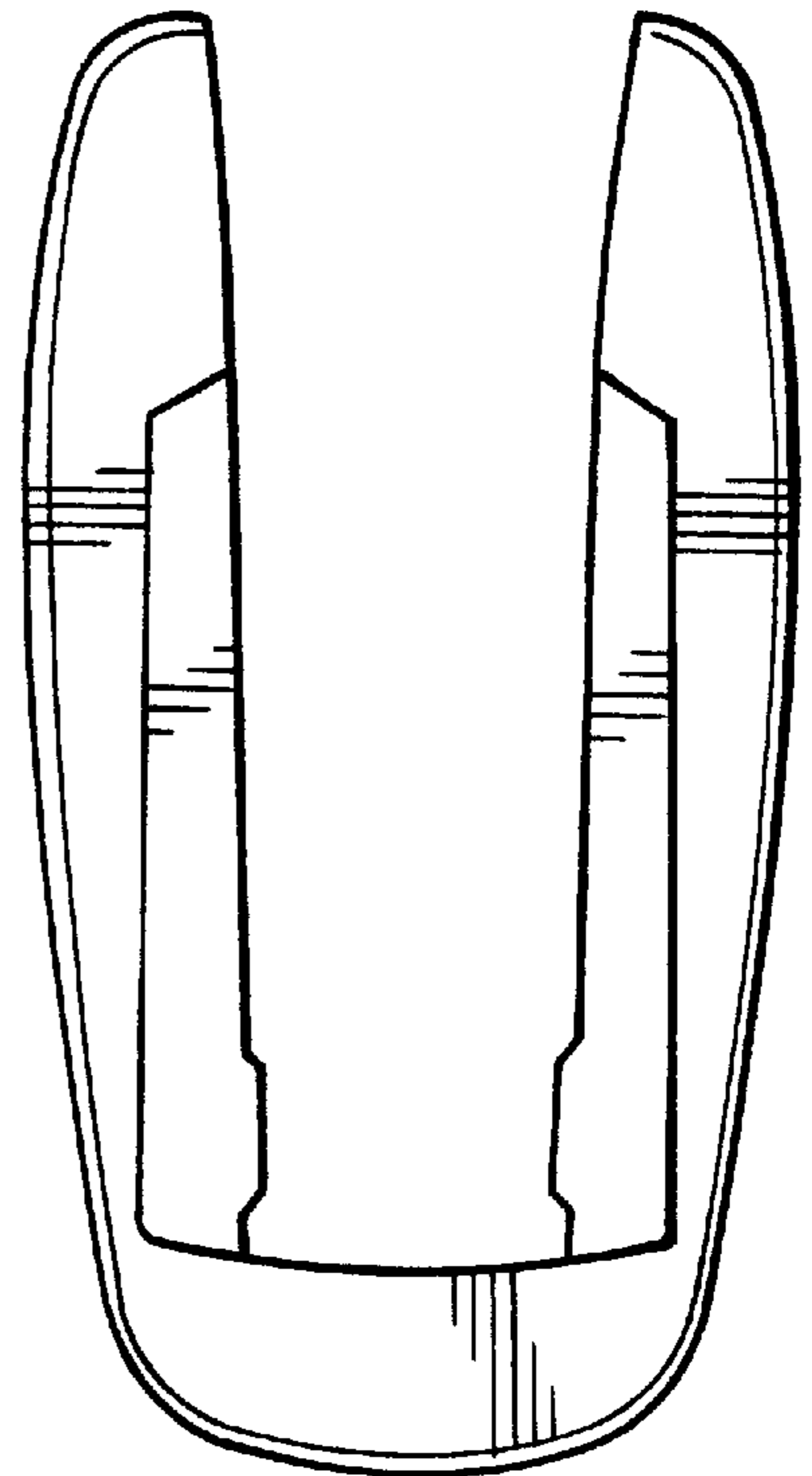

Fig-5

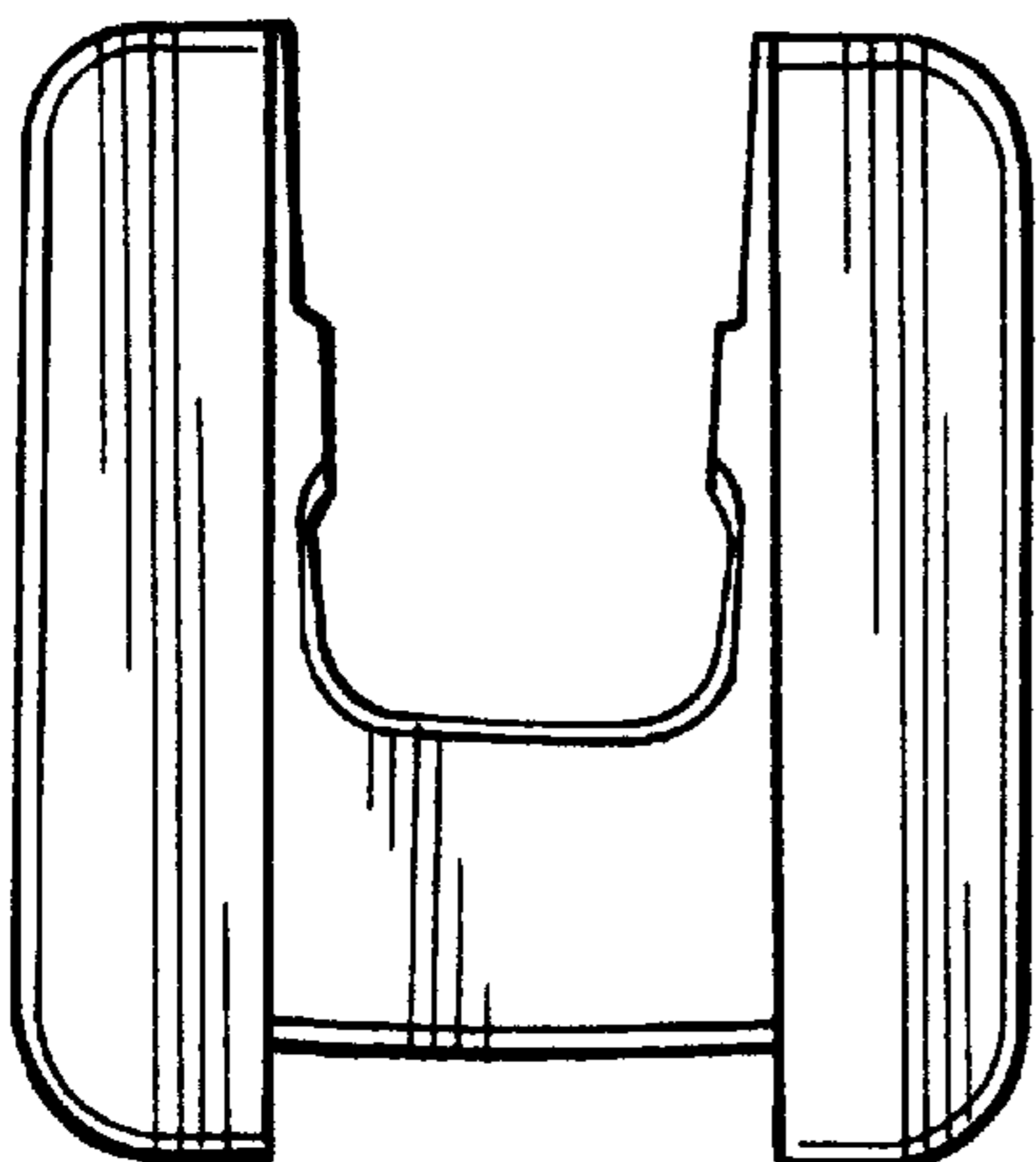

Fig-6