



US00D407798S

United States Patent [19] Pitsch

[11] Patent Number: **Des. 407,798**

[45] Date of Patent: ****Apr. 6, 1999**

[54] **FAUCET BODY**

[75] Inventor: **Walter Pitsch**, Franklin Park, N.J.

[73] Assignee: **American Standard Inc.**, Piscataway, N.J.

[**] Term: **14 Years**

[21] Appl. No.: **79,554**

[22] Filed: **Nov. 19, 1997**

[51] **LOC (6) Cl.** **23-01**

[52] **U.S. Cl.** **D23/241**

[58] **Field of Search** D23/238-243,
D23/250-257; 4/675-678; 137/801

[56] **References Cited**

U.S. PATENT DOCUMENTS

- D. 169,551 5/1953 Kendrick .
- D. 187,846 5/1960 Brown .
- D. 250,272 11/1978 Jones .
- D. 299,518 1/1989 Yost .
- D. 323,877 2/1992 Haug et al. .
- D. 325,423 4/1992 Kolada et al. .
- D. 329,685 9/1992 Brattoli et al. .
- D. 346,852 5/1994 Hill .
- D. 365,142 12/1995 Hill et al. .
- D. 369,208 4/1996 Doughty et al. .
- D. 373,616 9/1996 Doughty et al. .
- D. 373,618 9/1996 Doughty et al. .
- D. 373,621 9/1996 Doughty et al. .
- D. 374,706 10/1996 Doughty et al. .
- D. 381,066 7/1997 Hill et al. .
- D. 382,940 8/1997 Ku .
- 3,035,612 5/1962 Lyon .
- 3,533,436 10/1970 Parkinson .
- 4,290,445 9/1981 Turner .
- 4,356,574 11/1982 Johnson .

- 4,387,738 6/1983 Bisonaya et al. .
- 4,513,769 4/1985 Purcell .
- 4,649,958 3/1987 Purcell .
- 4,747,428 5/1988 Crawford et al. .
- 4,751,943 6/1988 Chi .
- 5,010,917 4/1991 Iqbal .
- 5,031,657 7/1991 Stairs .
- 5,131,428 7/1992 Bory .
- 5,165,121 11/1992 McTargett et al. .
- 5,368,071 11/1994 Hsieh .
- 5,642,755 7/1997 Mark et al. .

FOREIGN PATENT DOCUMENTS

- 485346 10/1991 European Pat. Off. .

OTHER PUBLICATIONS

Delta-Delex Facuets Catalog—1976.
Domestic Engineering —Kitchen and Bath—1989.

Primary Examiner—Louis S. Zarfes
Assistant Examiner—Eric Watterson
Attorney, Agent, or Firm—Joseph M. Homa

[57] **CLAIM**

The ornamental design for a faucet body, as shown and described.

DESCRIPTION

FIG. 1 is a top, front and left side perspective view of a faucet body showing my new design;
FIG. 2 is a top plan view thereof;
FIG. 3 is a right side elevational view thereof;
FIG. 4 is a left side elevational view thereof;
FIG. 5 is a front elevational view thereof;
FIG. 6 is a back elevational view thereof; and,
FIG. 7 is a bottom plan view thereof.

1 Claim, 4 Drawing Sheets

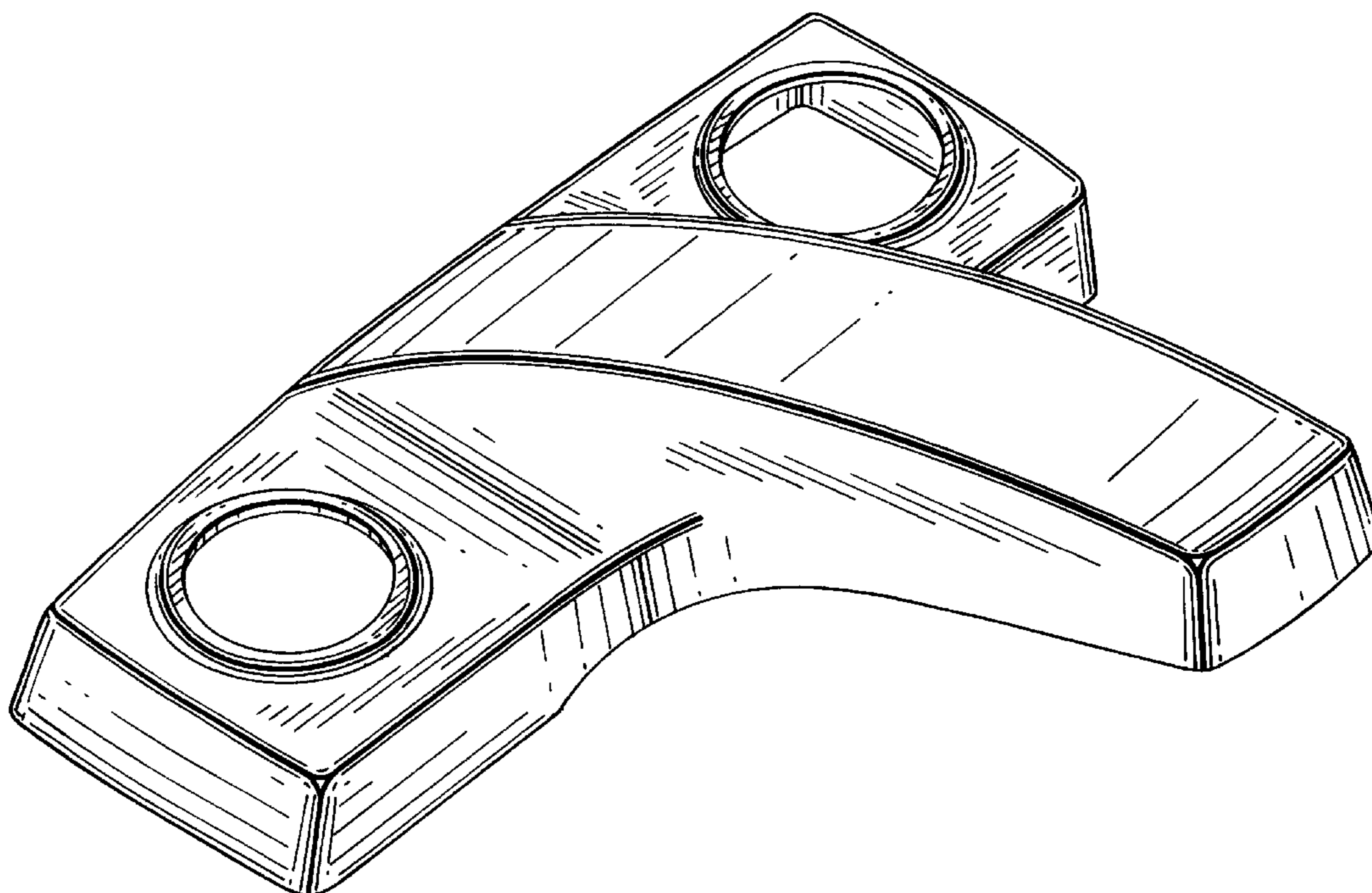

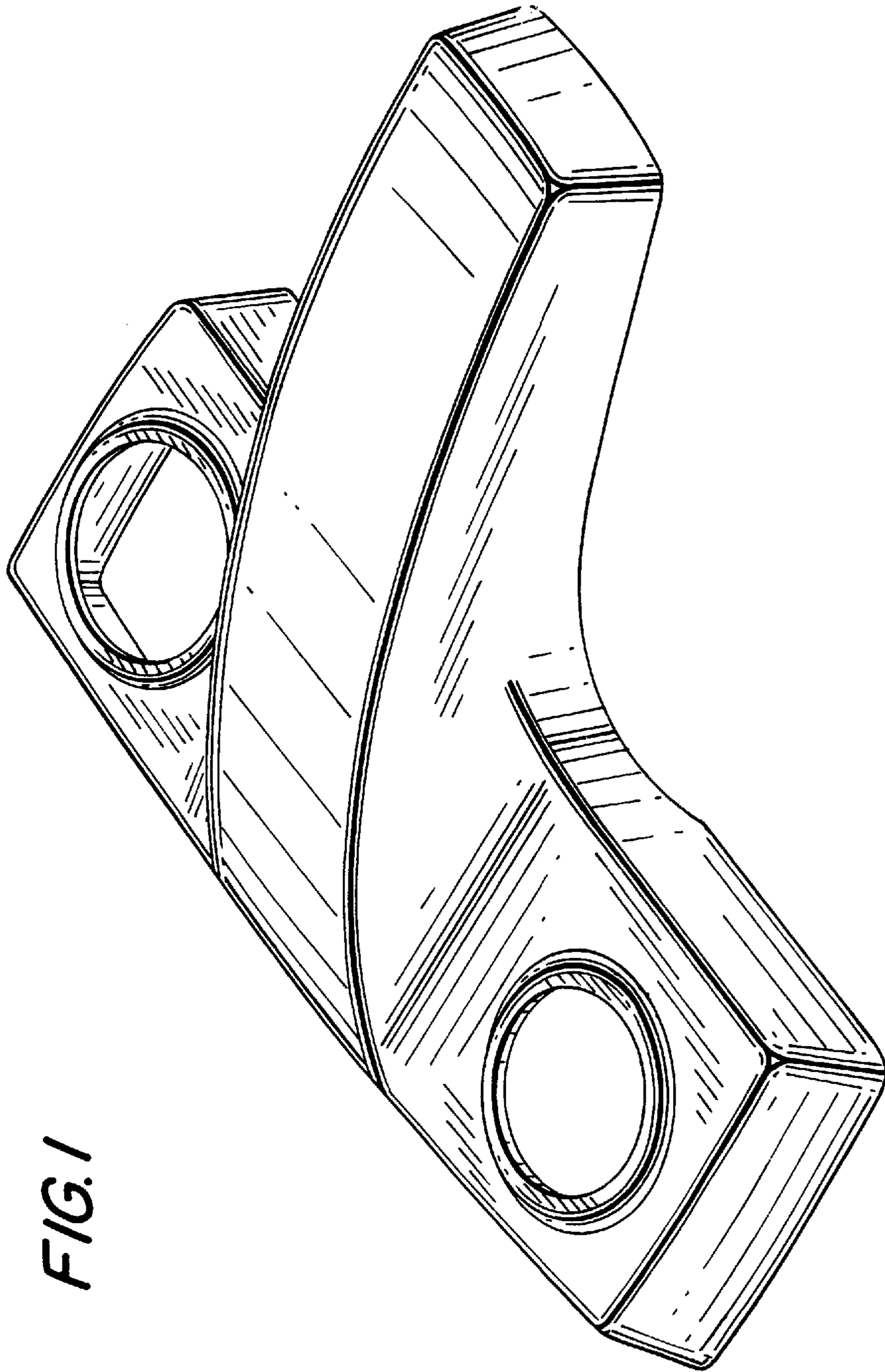

FIG. 1

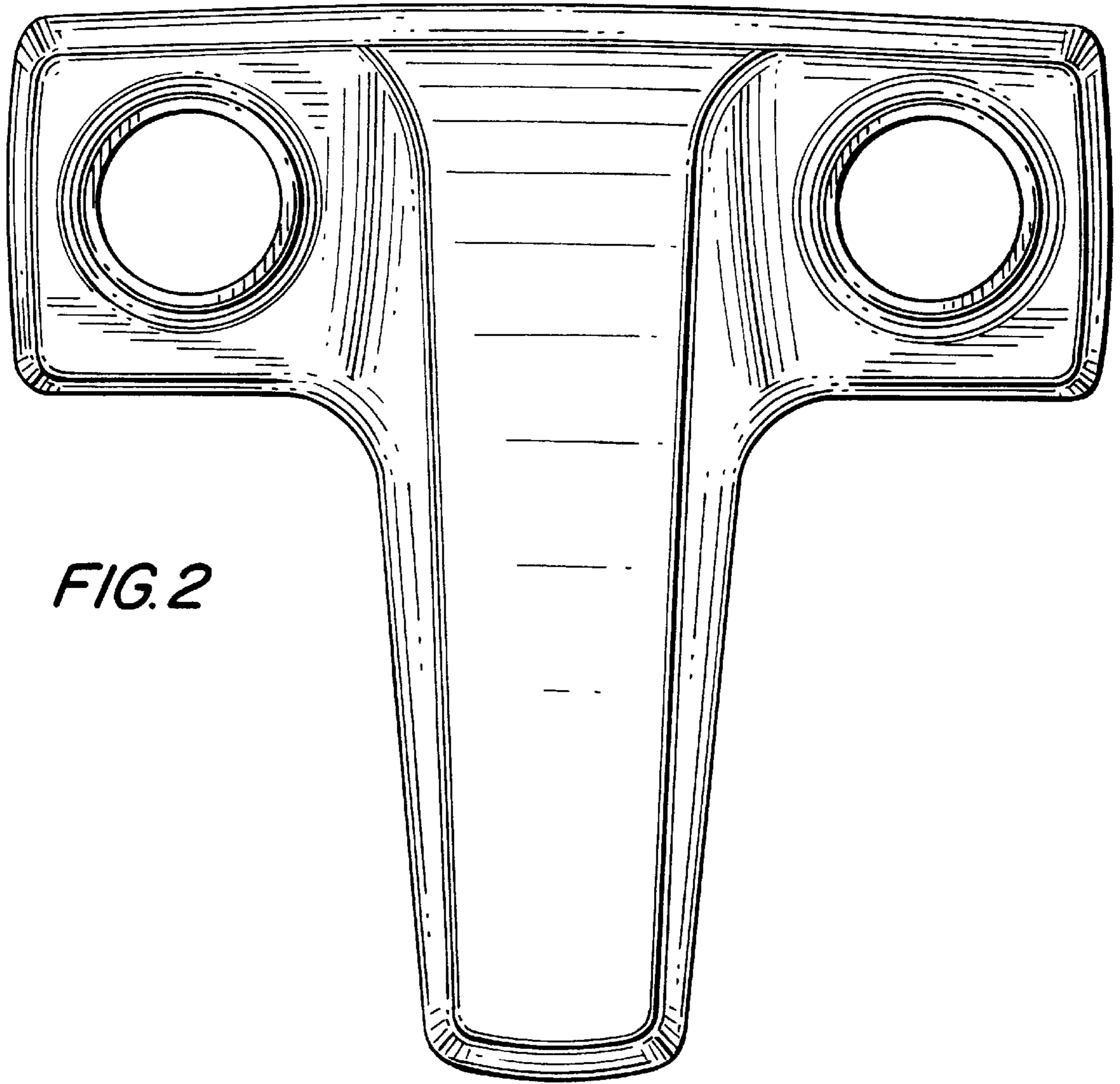

FIG. 2

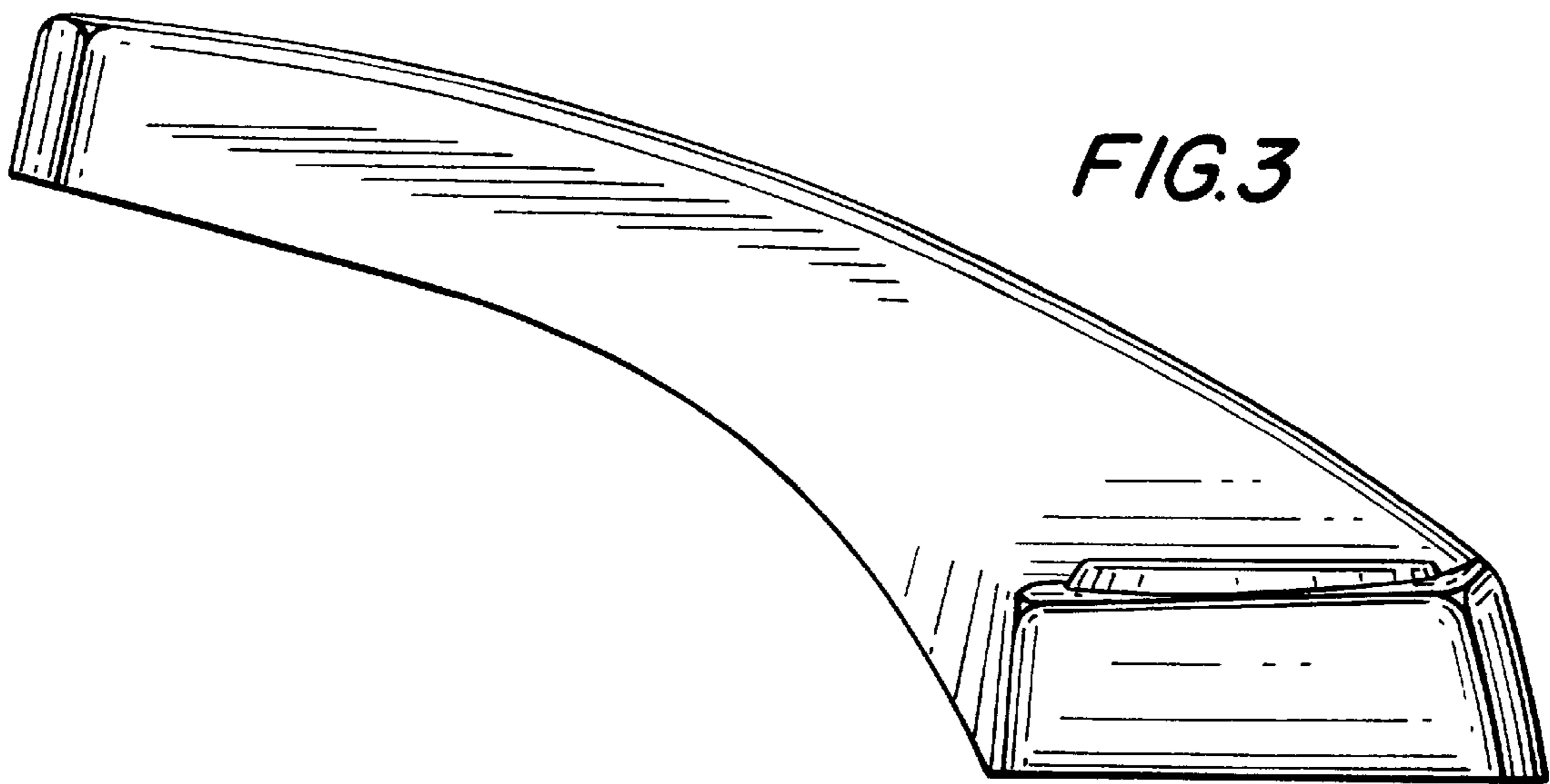

FIG. 3

FIG. 4

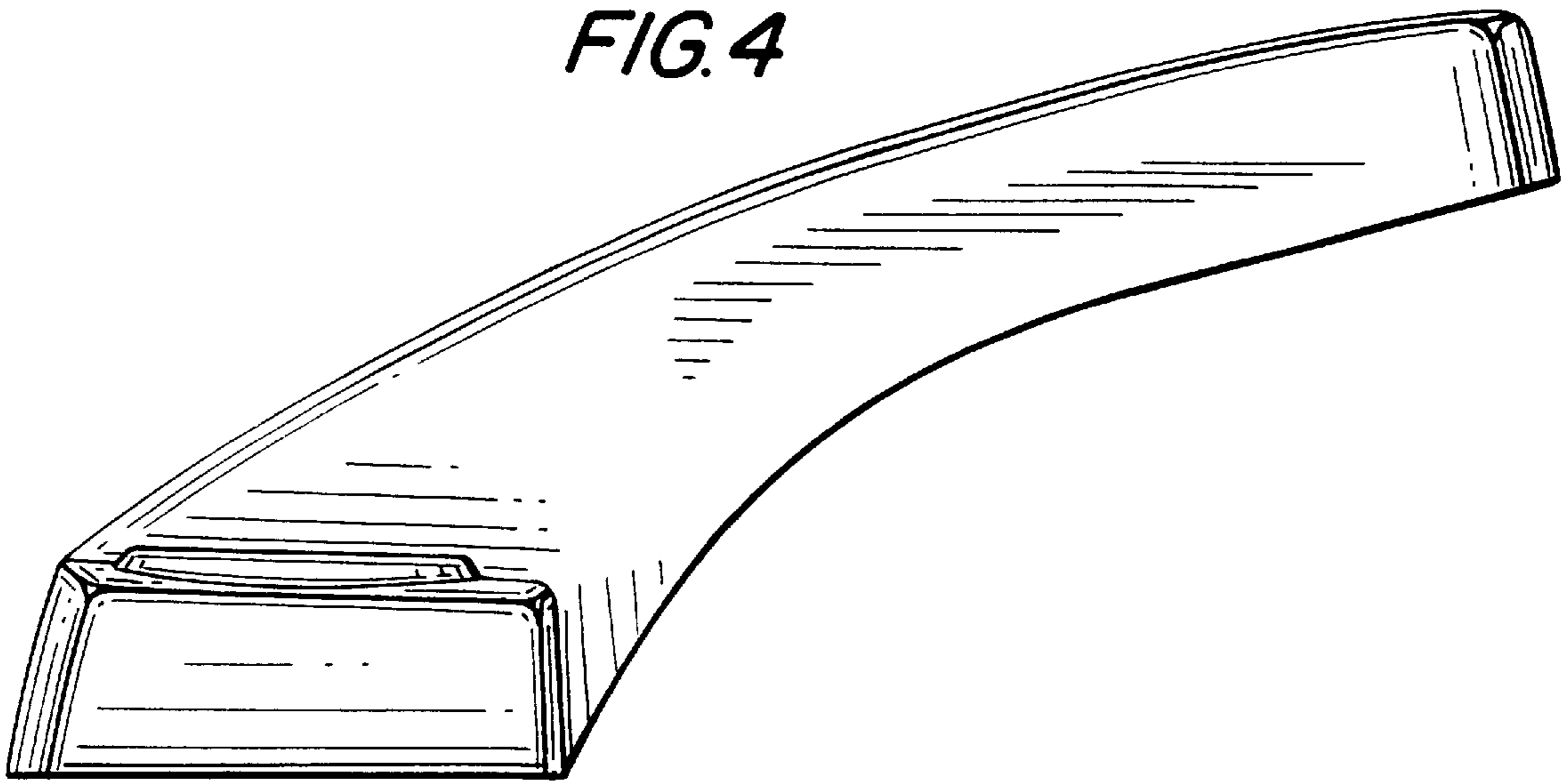

FIG. 5

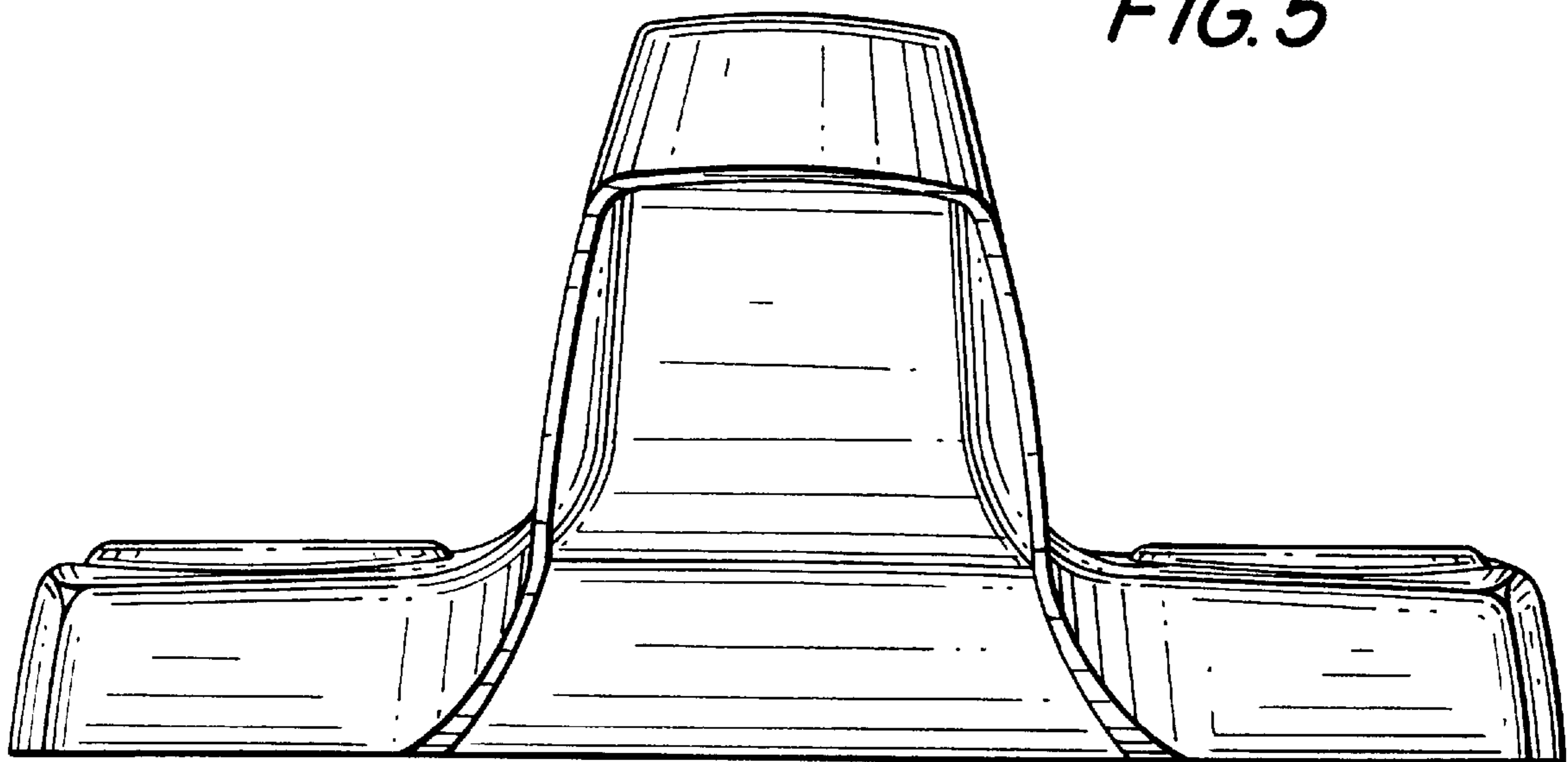

FIG. 6

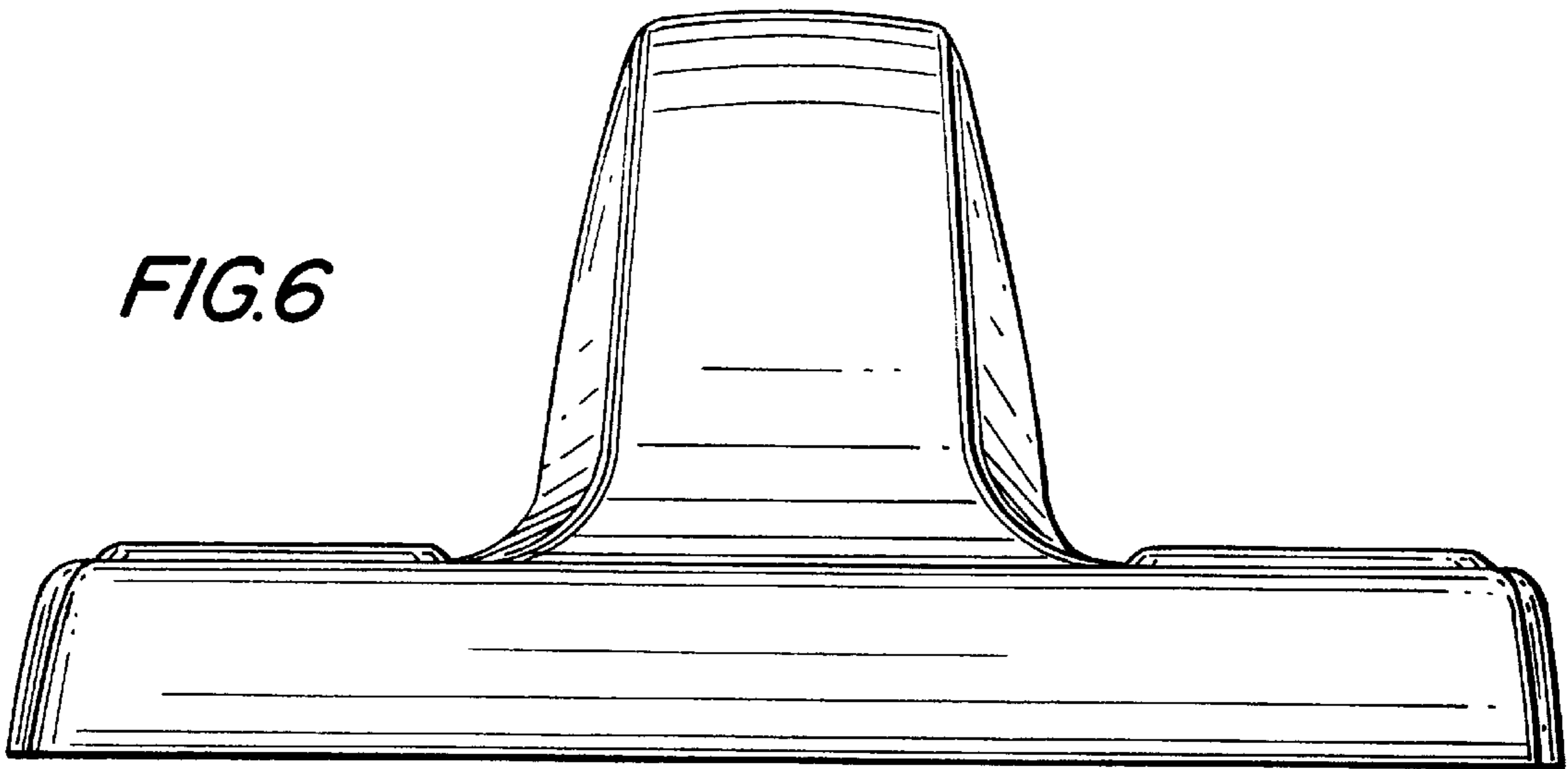

FIG. 7

