



US00D407365S

United States Patent [19] Nogal

[11] **Patent Number: Des. 407,365**

[45] **Date of Patent: **Mar. 30, 1999**

[54] **VEHICLE WHEEL FRONT FACE**

D. 395,862 7/1998 Cullen D12/209

[75] Inventor: **Leonardo Nogal**, Long Beach, Calif.

OTHER PUBLICATIONS

[73] Assignee: **American Racing Equipment, Inc.**,
Rancho Dominguez, Calif.

Prime Wheel Catalog, 1994.
Performance Handbook, 1996, pp. 31, 46 & 49.
American Racing Equipment Custom Wheels 1995, *American Racing Equipment*, pp. 3 & 5 (1994).
American Racing Equipment Custom Wheels 1990, *American Racing Equipment* (1989).
Performance Wheel, Tire & Suspension Handbook, *A Supplement to SEMA News*, pp. 9, 38 & 47 (no date).
1996 Performance Wheel, Tire & Suspension Handbook, *A Supplement to SEMA News*, pp. 28, 49 & 54.

[**] Term: **14 Years**

[21] Appl. No.: **87,388**

[22] Filed: **May 1, 1998**

[51] **LOC (6) Cl.** **12-16**

[52] **U.S. Cl.** **D12/209**

[58] **Field of Search** D12/204-213;
301/64.1, 65, 37.1

Primary Examiner—Jeffrey Asch
Assistant Examiner—Stacia Sinuik
Attorney, Agent, or Firm—Thompson Hine & Flory LLP

[56] **References Cited**

[57] **CLAIM**

U.S. PATENT DOCUMENTS

The ornamental design for a vehicle wheel front face, as shown and described.

D. 268,260	3/1983	Kerschbaum	D12/209
D. 363,457	10/1995	Coddington	D12/701
D. 363,910	11/1995	Chung	D12/209
D. 366,641	1/1996	Neeper	D12/209
D. 371,761	7/1996	Abbott	D12/209
D. 378,078	2/1997	Cattaneo	D12/205
D. 384,629	10/1997	Nagashima	D12/209
D. 384,631	10/1997	Murray	D12/209
D. 384,633	10/1997	Syring	D12/211
D. 384,929	10/1997	Neeper	D12/209
D. 384,932	10/1997	Cullen	D12/211
D. 385,246	10/1997	Neeper	D12/209
D. 390,822	2/1998	Neeper	D12/209
D. 395,031	6/1998	Timm	D12/209

DESCRIPTION

FIG. 1 is a front elevational view of my new vehicle wheel front face; and,
FIG. 2 is a perspective view taken from the left hand side thereof.

The broken lines shown in FIGS. 1 and 2 of the drawings are for illustrative purposes only and the subject matter depicted thereby constitutes no part of the claimed design.

1 Claim, 2 Drawing Sheets

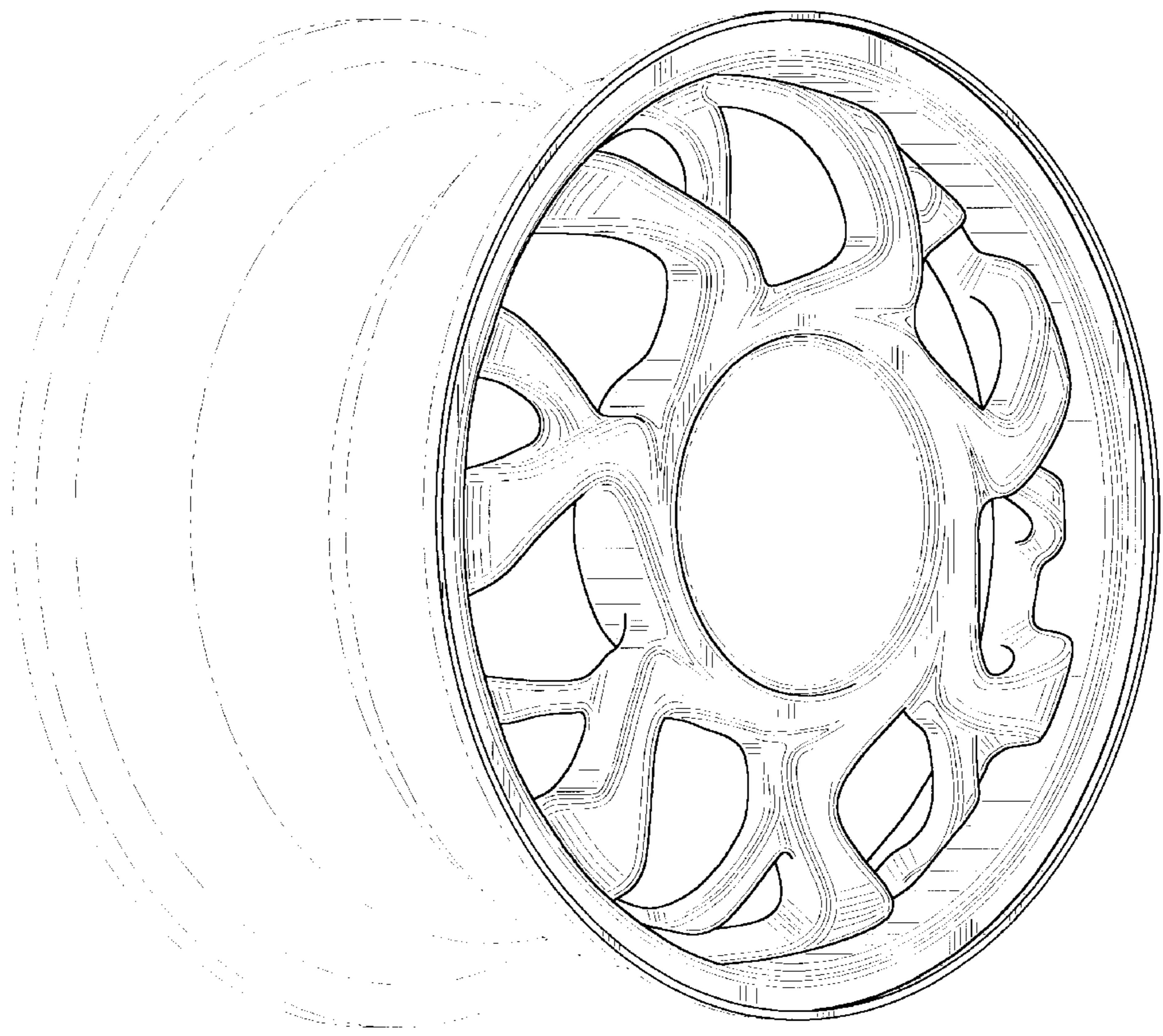

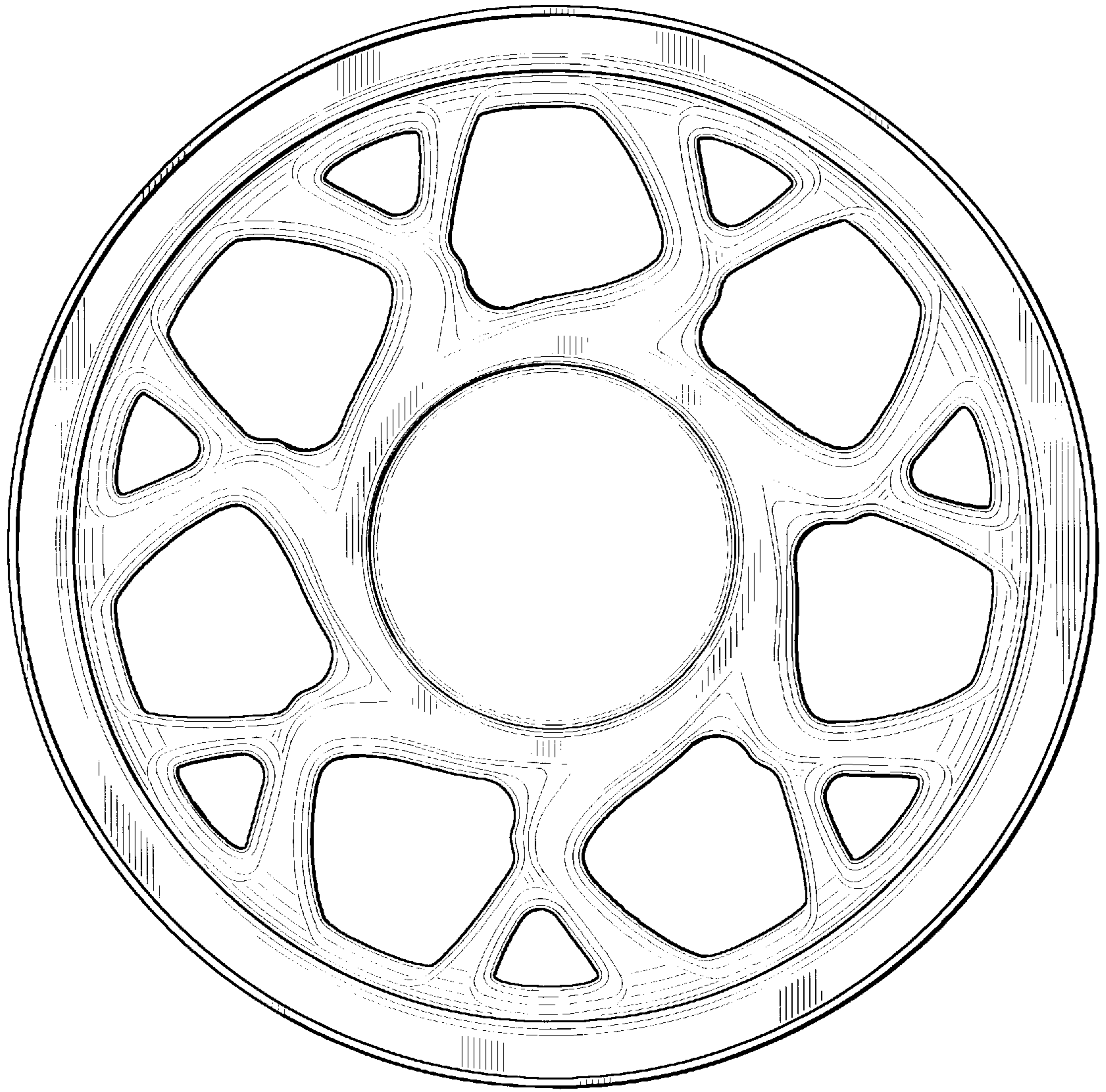

FIG. 1

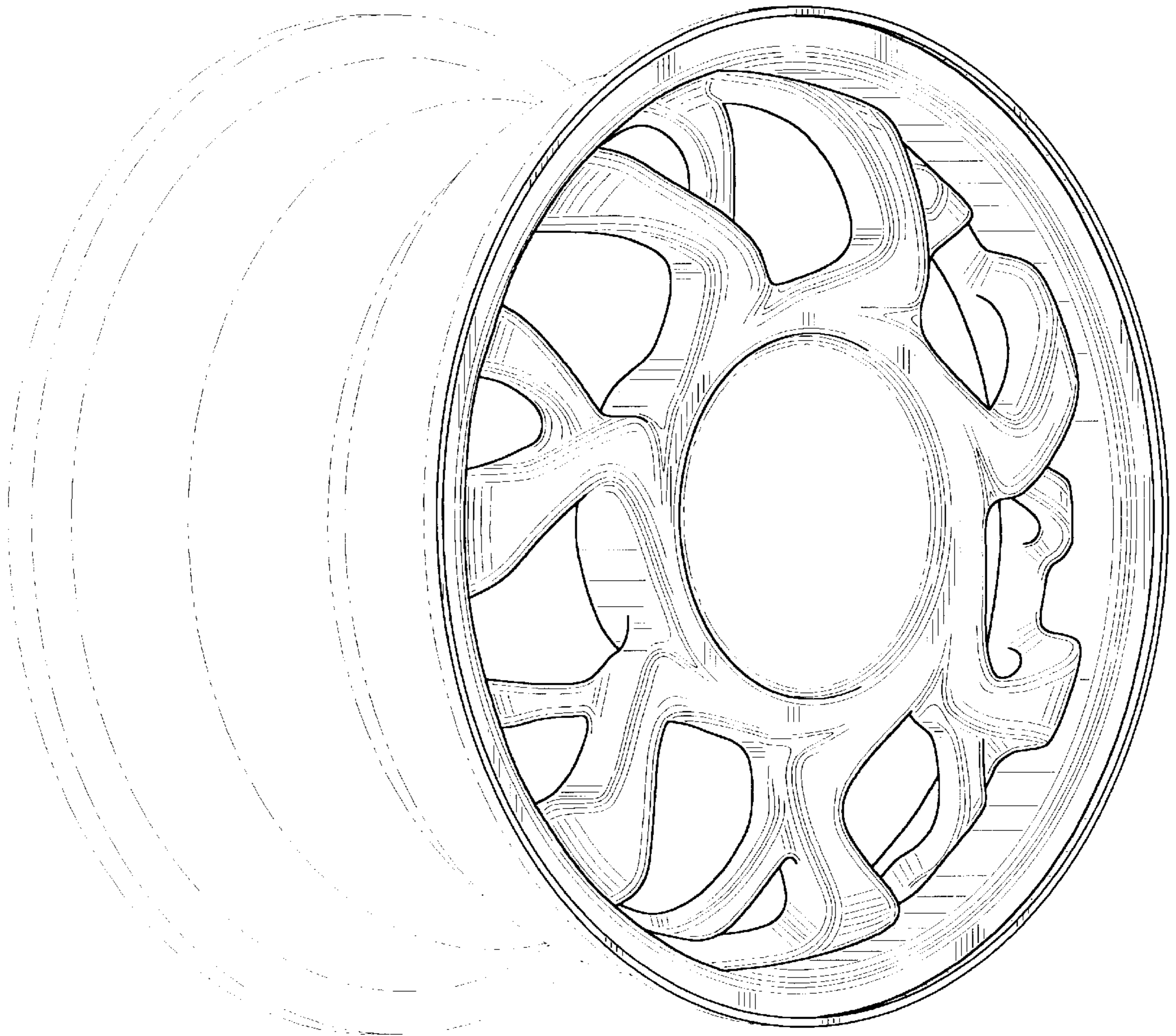

FIG. 2