

US00D407364S

United States Patent [19] Fisker

[11] **Patent Number: Des. 407,364**

[45] **Date of Patent: **Mar. 30, 1999**

[54] **FRONT FACE OF A VEHICLE WHEEL**

[75] Inventor: **Henrik Fisker**, Westlake Village, Calif.

[73] Assignee: **Bayerische Motoren Werke Aktiengesellschaft**, Munich, Germany

[**] Term: **14 Years**

[21] Appl. No.: **81,999**

[22] Filed: **Jan. 13, 1998**

Related U.S. Application Data

[63] Continuation of Ser. No. 74,547, Aug. 5, 1997, abandoned.

[30] Foreign Application Priority Data

Feb. 5, 1997 [DE] Germany M 97 01 285.8

[51] **LOC (6) Cl.** **12-16**

[52] **U.S. Cl.** **D12/209**

[58] **Field of Search** D12/204-213;
301/64.1, 65, 37.1

[56] References Cited

U.S. PATENT DOCUMENTS

- D. 267,546 1/1983 Wright D12/211
- D. 361,547 8/1995 Weld D12/211
- D. 368,885 4/1996 Wagner D12/209
- D. 379,612 6/1997 Honarkhah D12/209
- D. 380,432 7/1997 Hettler D12/209

- D. 384,025 9/1997 Roesianto D12/209
- D. 384,320 9/1997 Bhambra D12/209
- D. 391,215 2/1998 Cervati D12/209
- D. 391,543 3/1998 Renkert D12/209

FOREIGN PATENT DOCUMENTS

M 94 00 761 7/1994 Germany D12/211

OTHER PUBLICATIONS

Road & Track, Aug. 1996, p. 8., See "RWS5s"; p. 114, See Borbet Type M; p. 115, See Mille Miglia Glide II. Motor Trend, Jan. 1997, p. 81, See "Oz Competition".

Primary Examiner—James Gandy
Assistant Examiner—Stacia Sinuik
Attorney, Agent, or Firm—Evenson, McKeown, Edwards & Lenahan, P.L.L.C.

[57] CLAIM

The ornamental design for a front face of a vehicle wheel, as shown and described.

DESCRIPTION

FIG. 1 is a front view of a front face of a vehicle wheel according to my novel design; and, FIG. 2 is a perspective view of a front face of a vehicle wheel according to my novel design.

The broken lines are for illustrative purposes only and form no part of the claimed design.

1 Claim, 1 Drawing Sheet

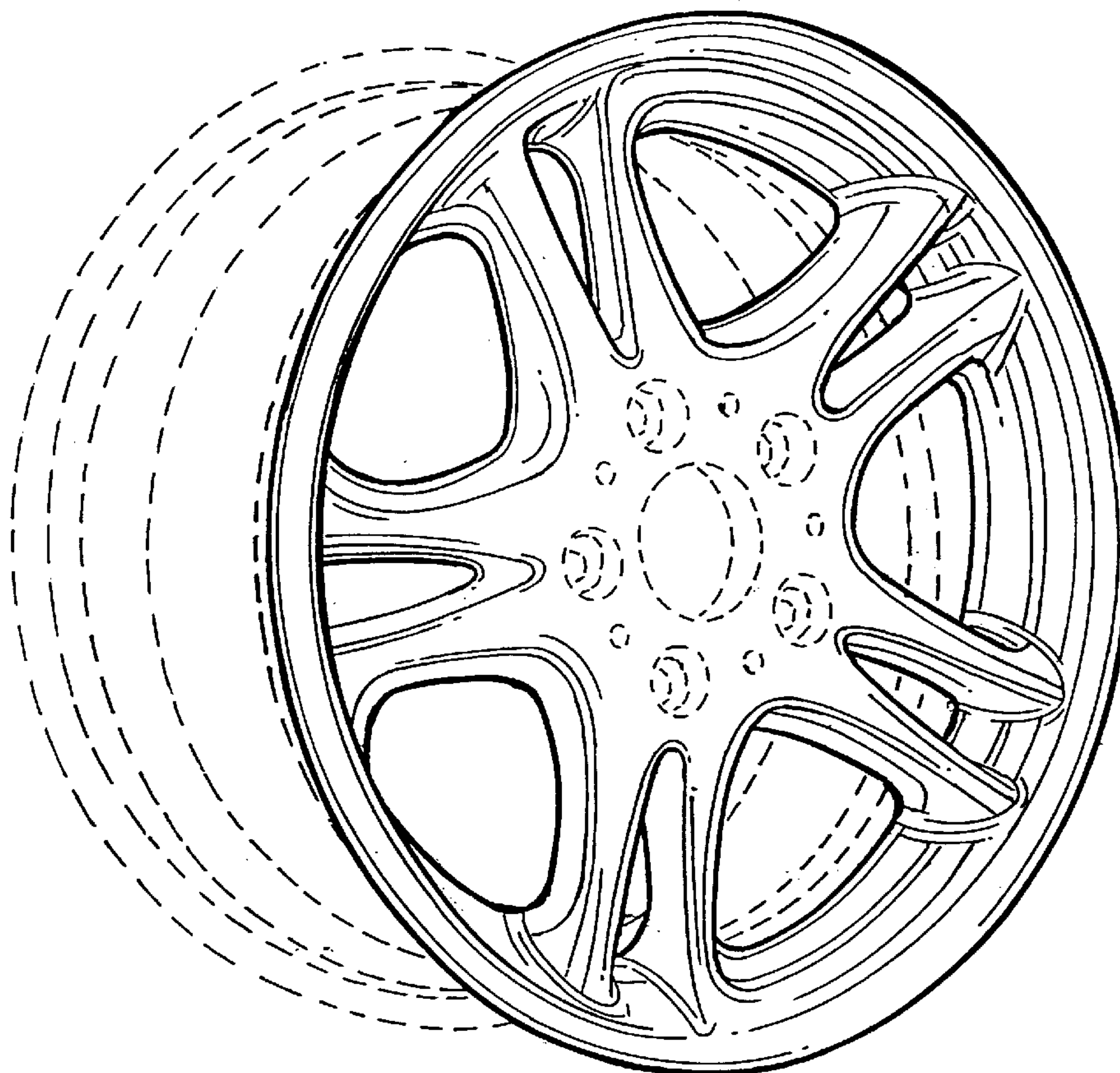

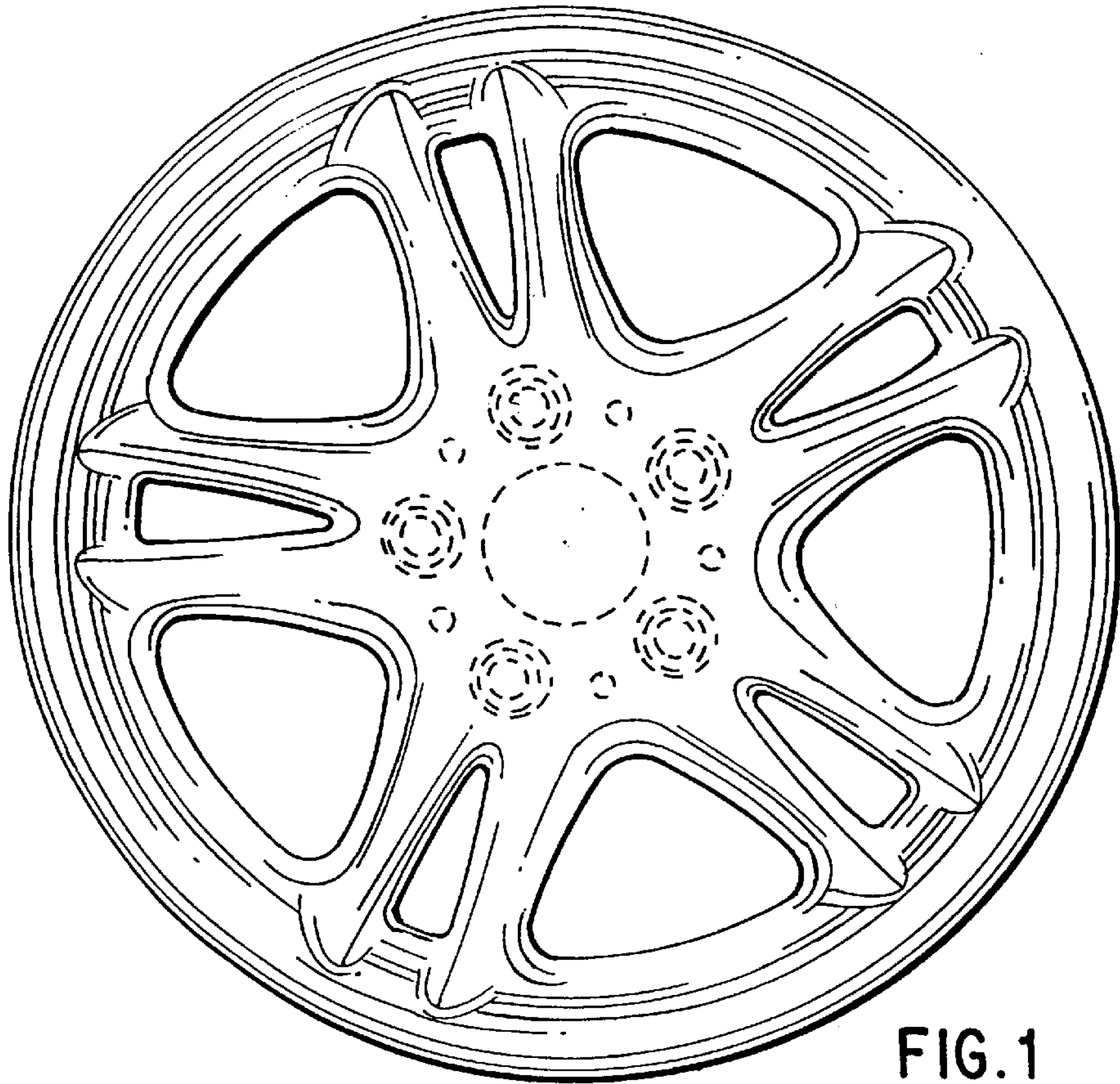

FIG. 1

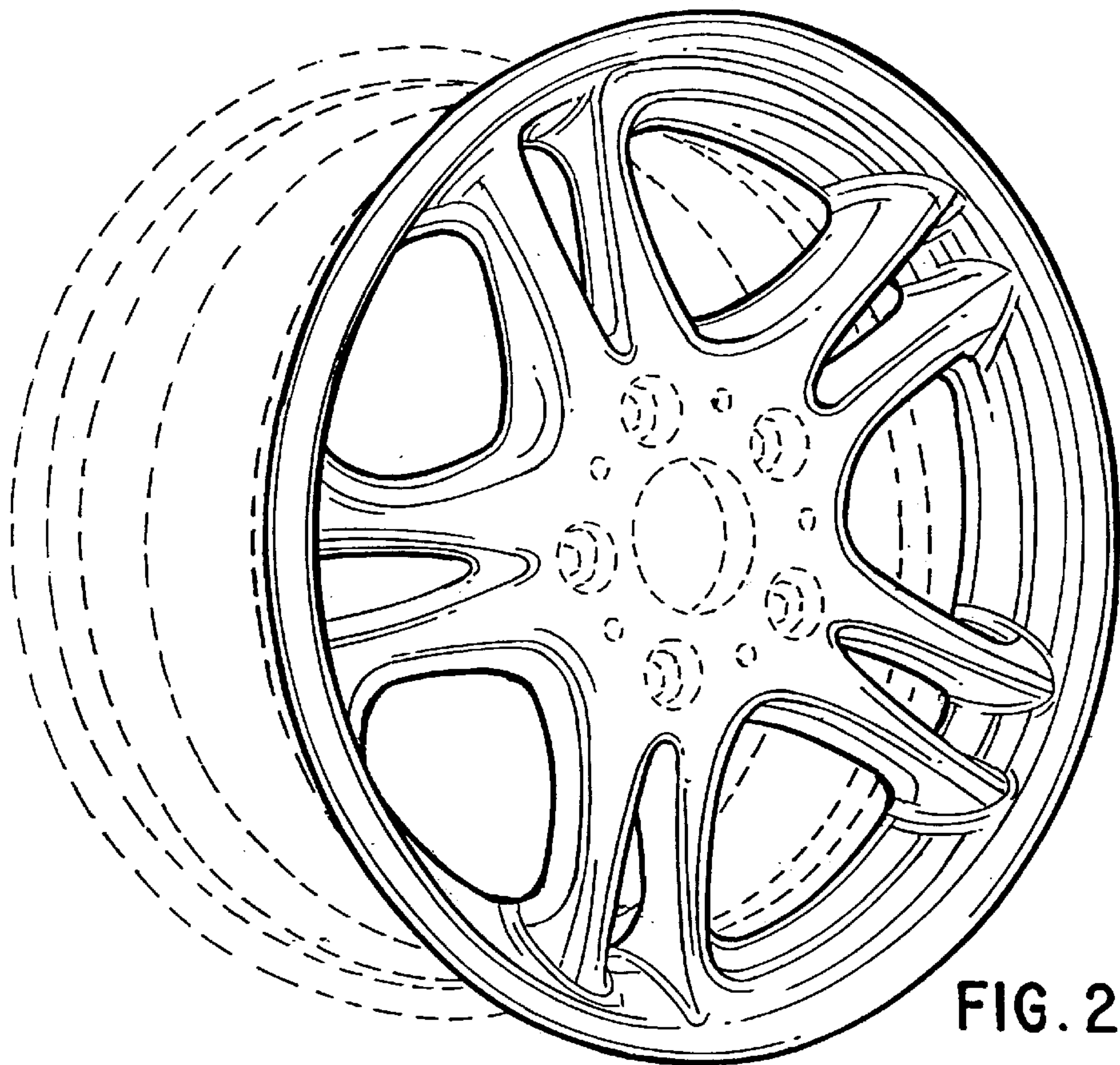

FIG. 2