



US00D407358S

United States Patent [19]
Redmond

[11] **Patent Number: Des. 407,358**

[45] **Date of Patent: **Mar. 30, 1999**

[54] **WHEEL ASSEMBLY FOR TRAILER**

3,717,364 2/1973 McClive 280/414.1

[76] Inventor: **Joseph R. Redmond**, 143 Winchell Dr.,
Syracuse, N.Y. 13209-1447

Primary Examiner—Doris V. Coles
Assistant Examiner—Stacia Sinuik
Attorney, Agent, or Firm—Dougherty & Associates

[**] Term: **14 Years**

[57] **CLAIM**

[21] Appl. No.: **81,167**

The ornamental design for a wheel assembly for trailer, as shown and described.

[22] Filed: **Dec. 23, 1997**

[51] **LOC (6) Cl.** **12-16**

[52] **U.S. Cl.** **D12/162**

[58] **Field of Search** D12/162, 400,
D12/408; 280/414.1, 414.2, 476.1, 504,
505, 433, 434, 491.1–491.4, 423.1, 425.1,
425.2

DESCRIPTION

FIG. 1 is a front perspective view of a wheel assembly for trailer, showing my new design;
FIG. 2 is a reduced top view thereof;
FIG. 3 is a reduced front elevational view thereof;
FIG. 4 is a reduced left side elevational view thereof, the right side being a mirror image thereof;
FIG. 5 is a reduced rear elevational view thereof; and,
FIG. 6 is a reduced bottom view thereof.

The broken line showing of environment is for illustrative purposes only and forms no part of the claimed design.

[56] **References Cited**

U.S. PATENT DOCUMENTS

D. 354,263	1/1995	Clark et al.	D12/162
D. 357,888	5/1995	Geddes	D12/408 X
D. 365,315	12/1995	Parker, Jr.	D12/162
D. 399,803	10/1998	Hilmen	D12/162

1 Claim, 2 Drawing Sheets

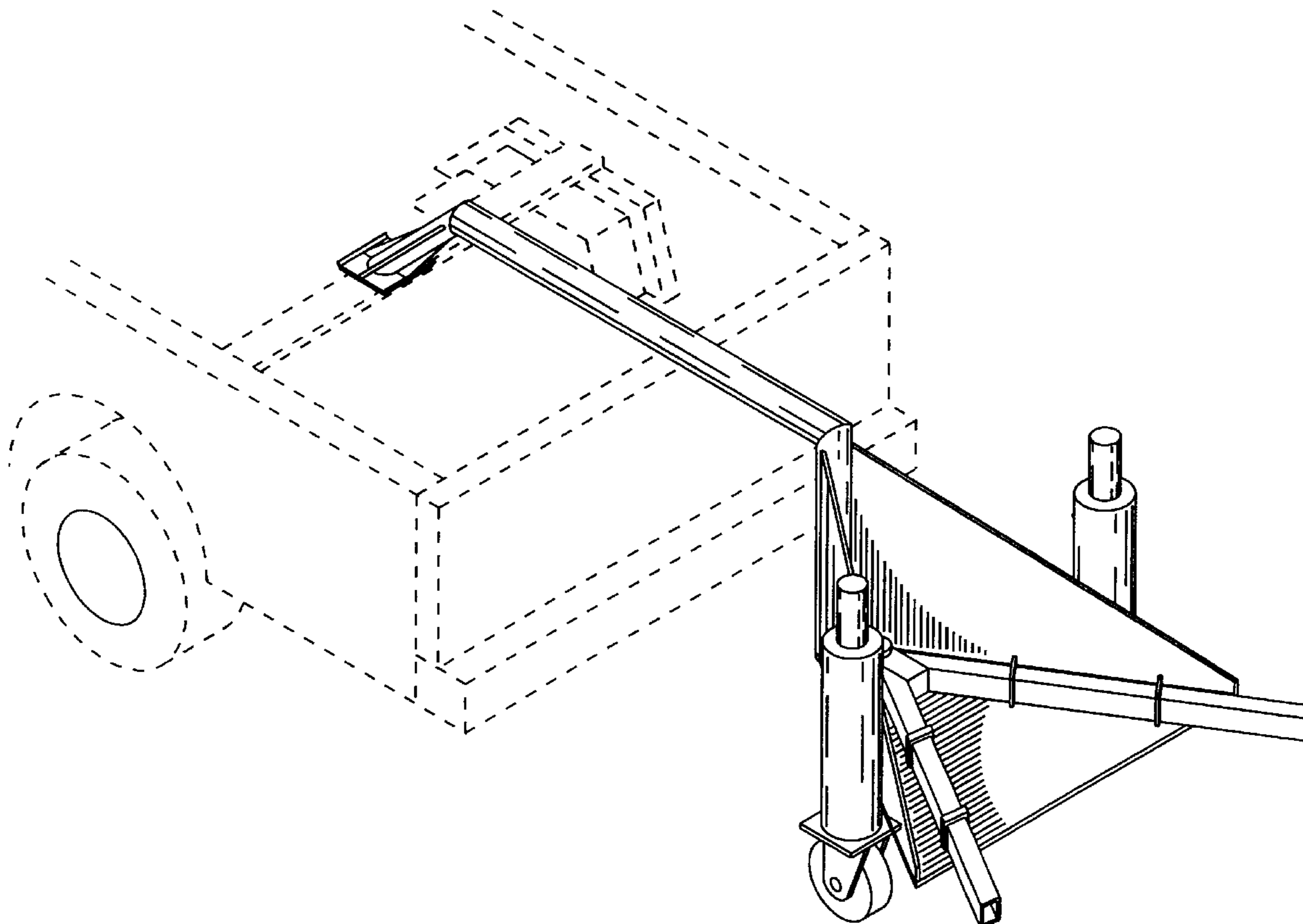

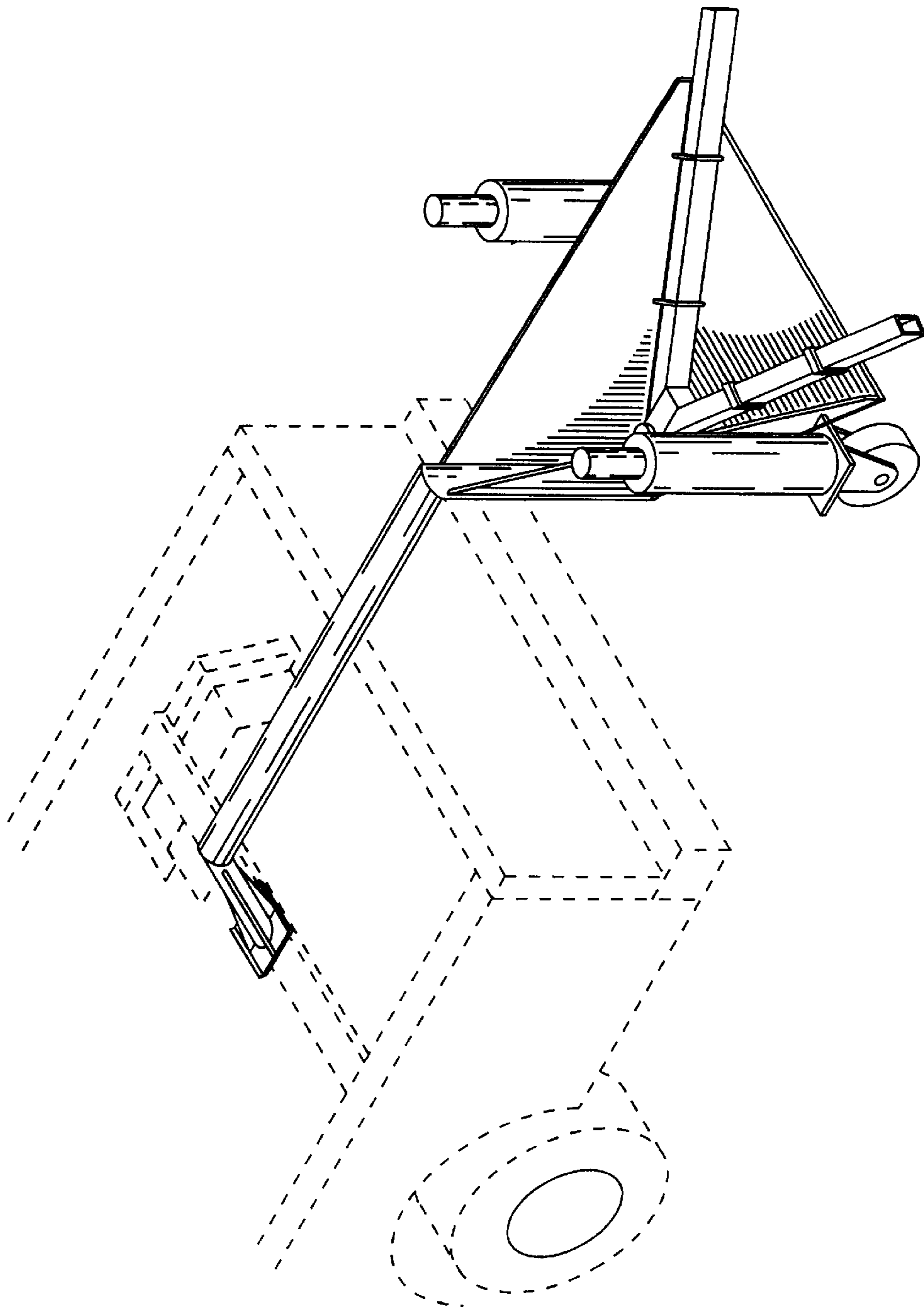

Fig. 1

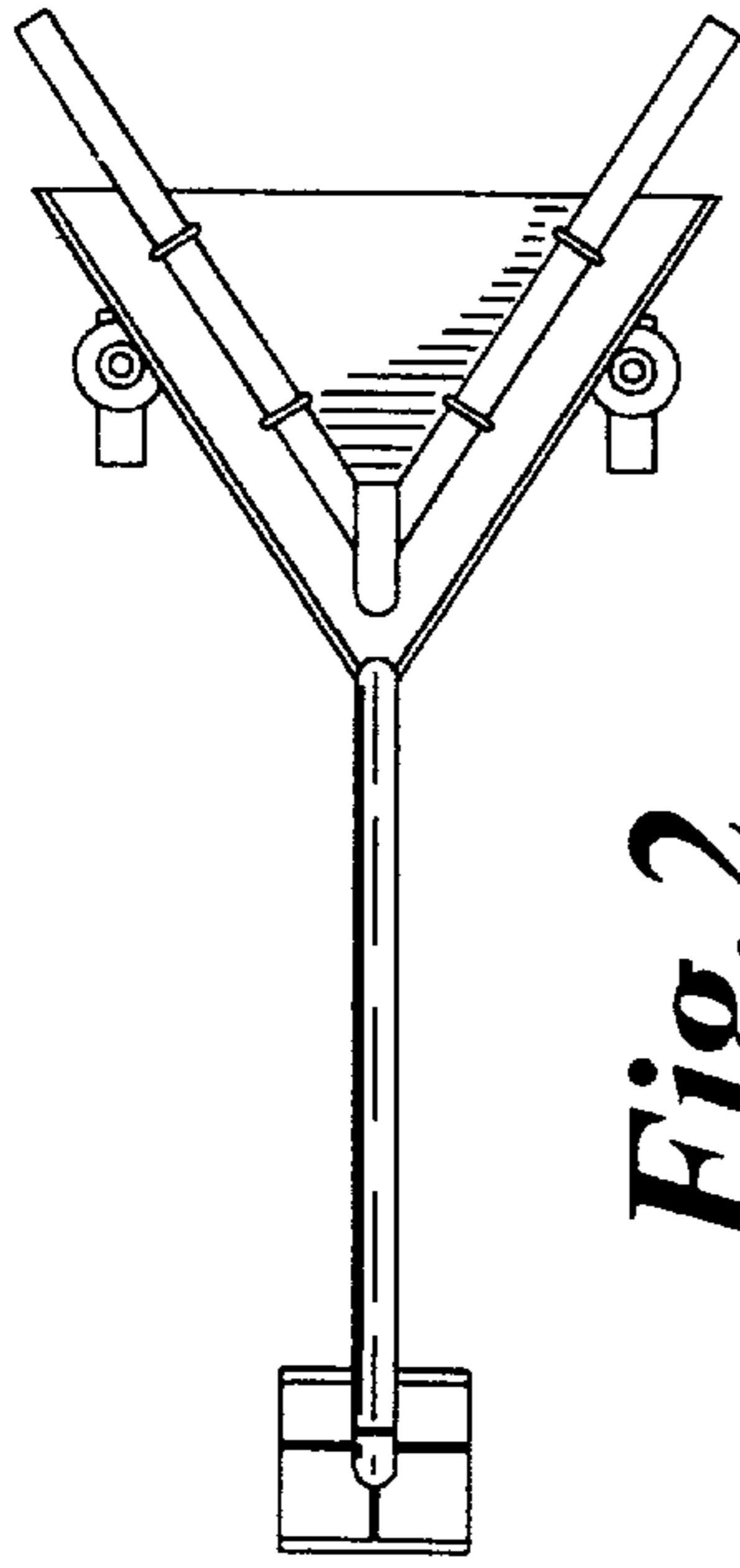

Fig. 2

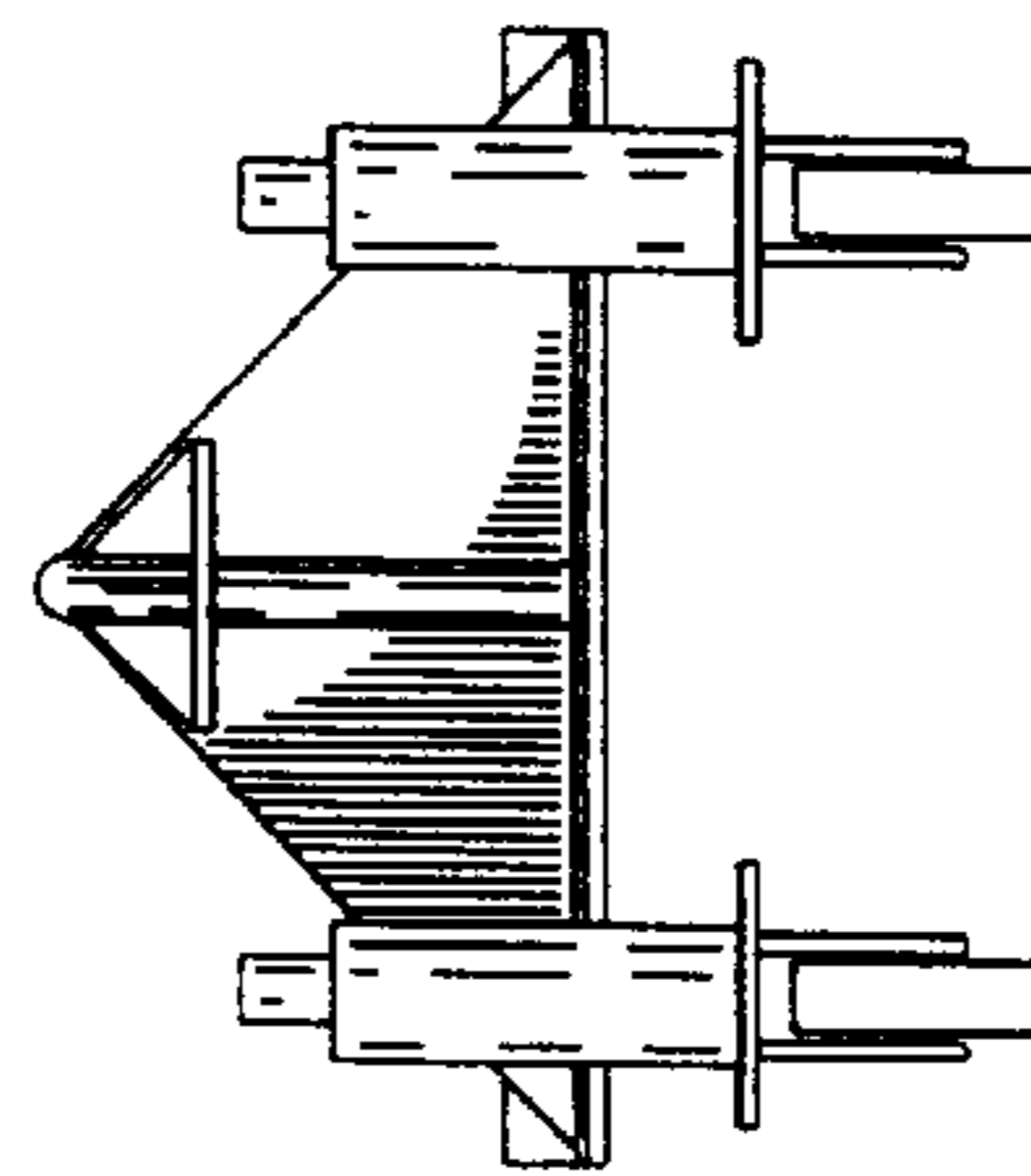

Fig. 3

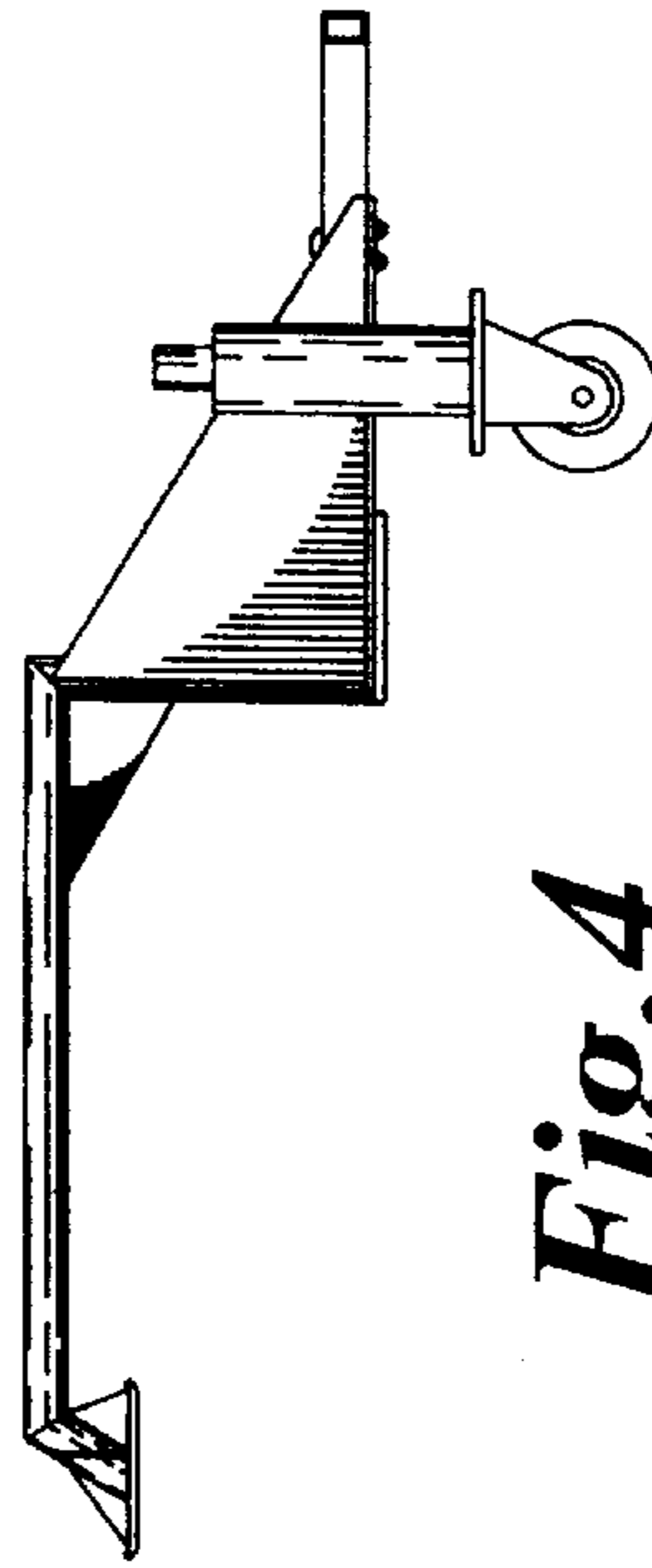

Fig. 4

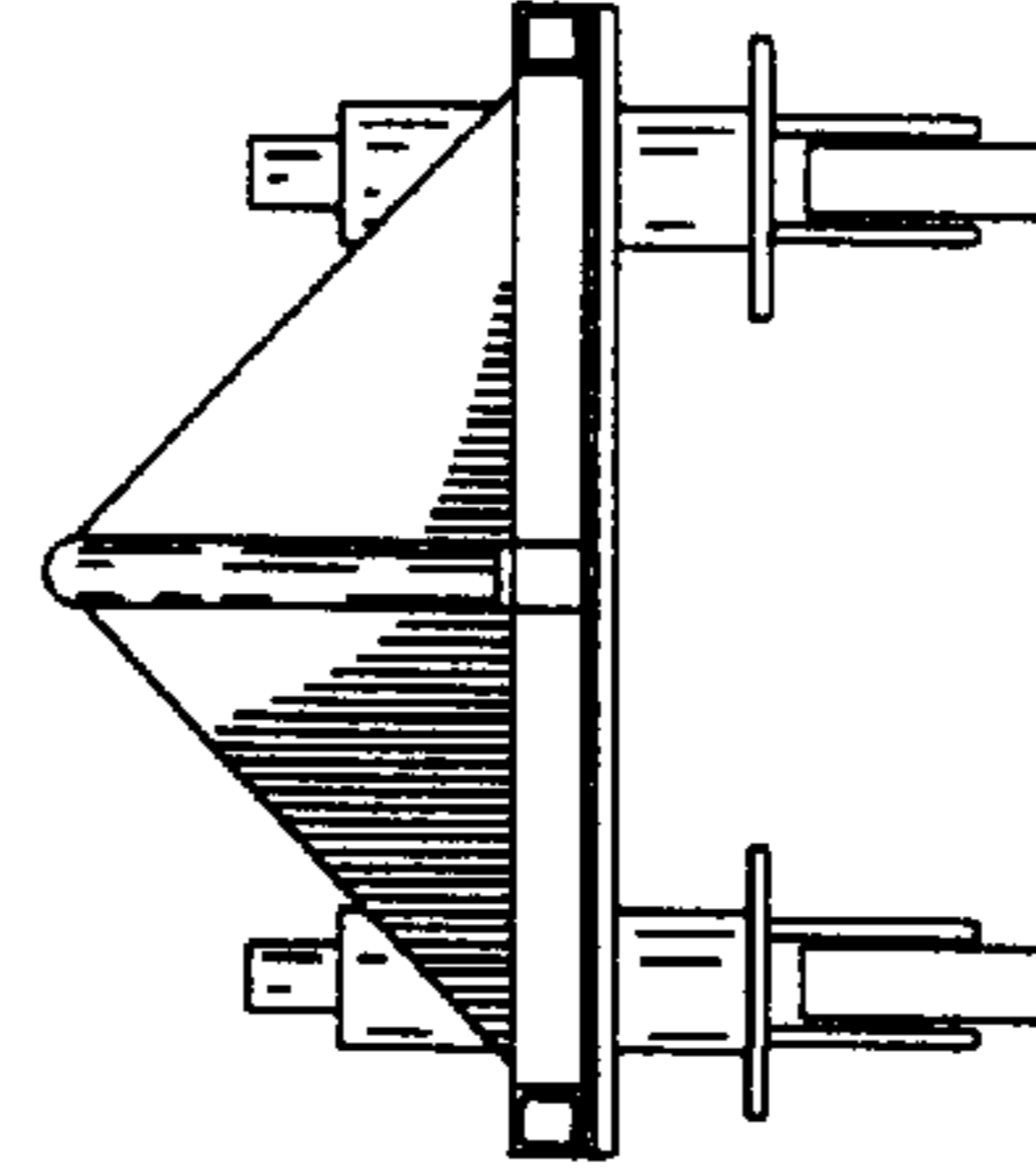

Fig. 5

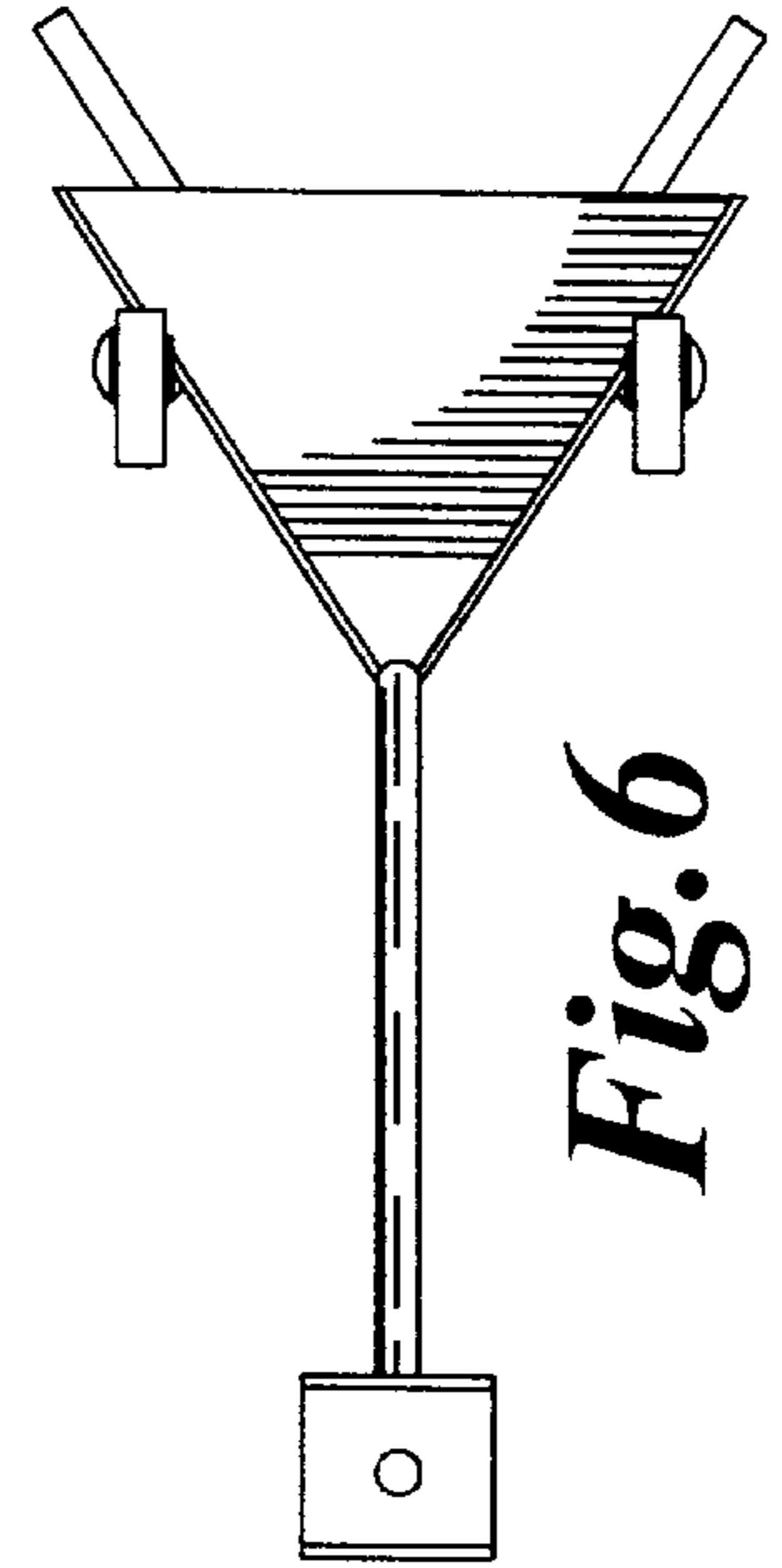

Fig. 6