



US00D407349S

United States Patent [19]

Murakami et al.

[11] **Patent Number: Des. 407,349**

[45] **Date of Patent: **Mar. 30, 1999**

[54] **AUTOMOBILE**

[75] Inventors: **Kunitoshi Murakami**, Muehlheim/M, Germany; **Narukiyo Nogami**, Wako, Japan; **Nicholas Geoffrey Alan Hull**, Freigericht, Germany

[73] Assignee: **Honda Giken Kogyo Kabushiki Kaisha**, Tokyo, Japan

[**] Term: **14 Years**

[21] Appl. No.: **74,988**

[22] Filed: **Aug. 18, 1997**

[30] **Foreign Application Priority Data**

Feb. 27, 1997 [JP] Japan 9-5714

[51] **LOC (6) Cl.** **12-08**

[52] **U.S. Cl.** **D12/91**

[58] **Field of Search** D12/90-92, 86; 296/185

[56] **References Cited**

U.S. PATENT DOCUMENTS

D. 332,587 1/1993 Halbert et al. .

D. 354,258 1/1995 Ikeda et al. D12/91
D. 376,563 12/1996 Sacco et al. D12/91
D. 378,074 2/1997 Sacco et al. D12/91

Primary Examiner—Melody N. Brown
Attorney, Agent, or Firm—Nikaido, Marmelstein, Murray & Oram LLP

[57] **CLAIM**

The ornamental design for an automobile, as shown and described.

DESCRIPTION

FIG. 1 is a left-front perspective view of an automobile showing our new design;

FIG. 2 is a left-rear perspective view thereof;

FIG. 3 is a left side view thereof;

FIG. 4 is a right side view thereof;

FIG. 5 is a front view thereof;

FIG. 6 is a rear view thereof; and,

FIG. 7 is a top plan view thereof.

1 Claim, 6 Drawing Sheets

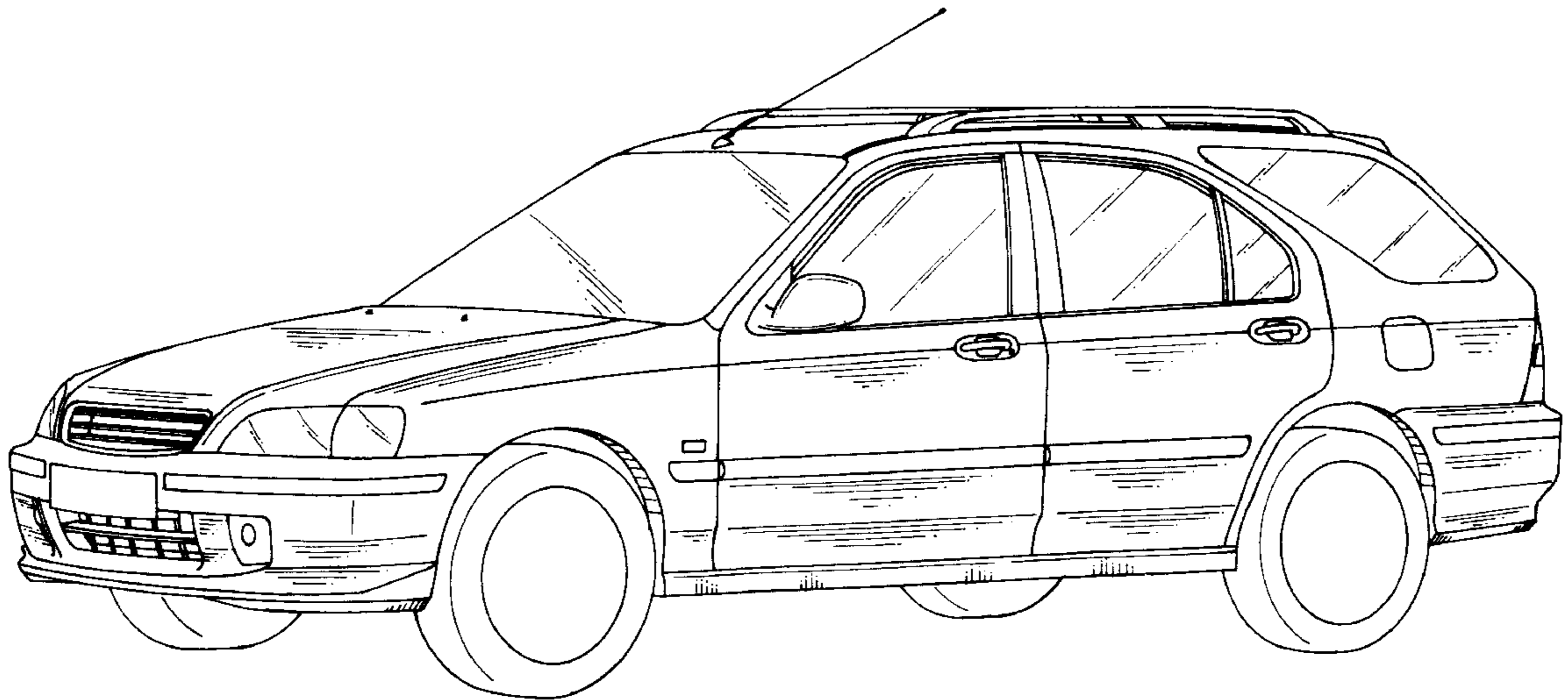

FIG. 1

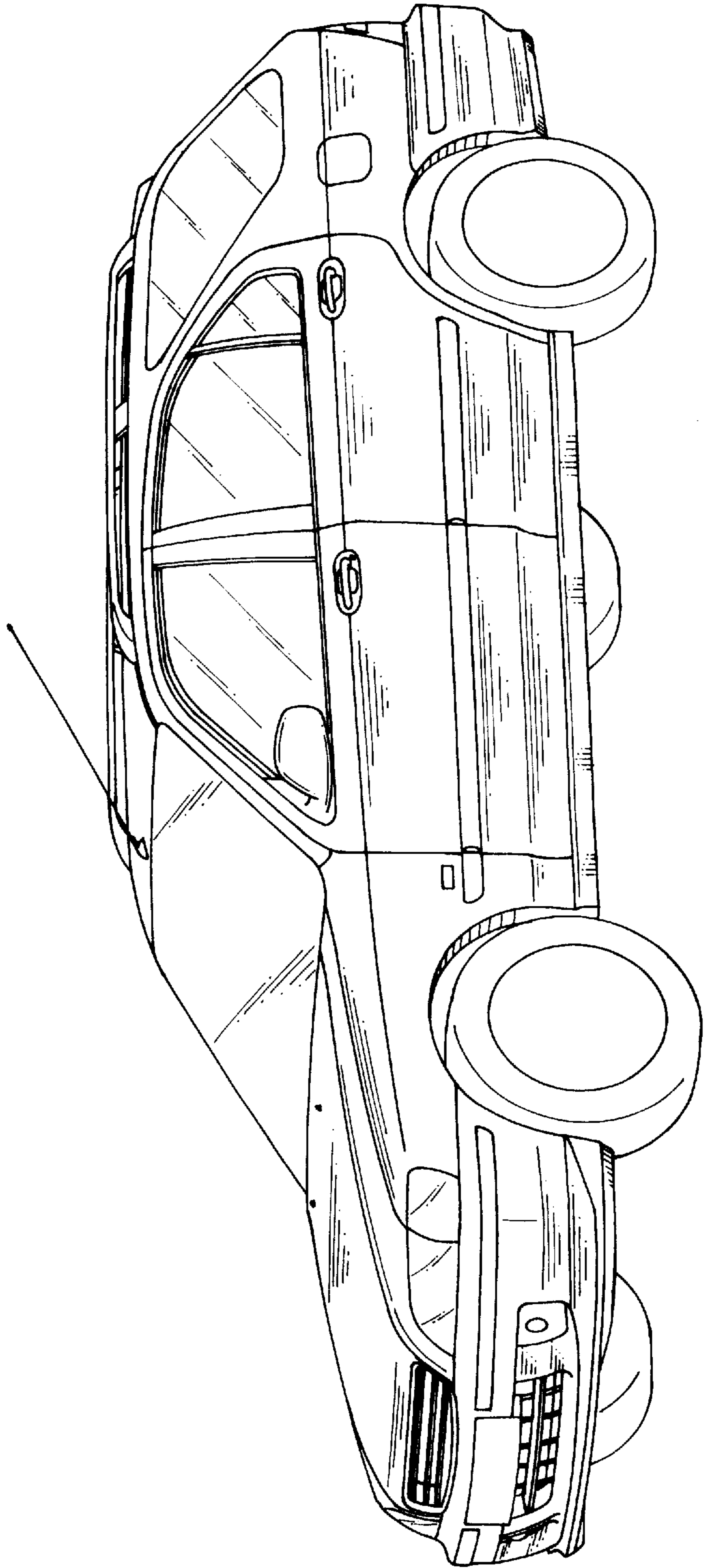

FIG. 2

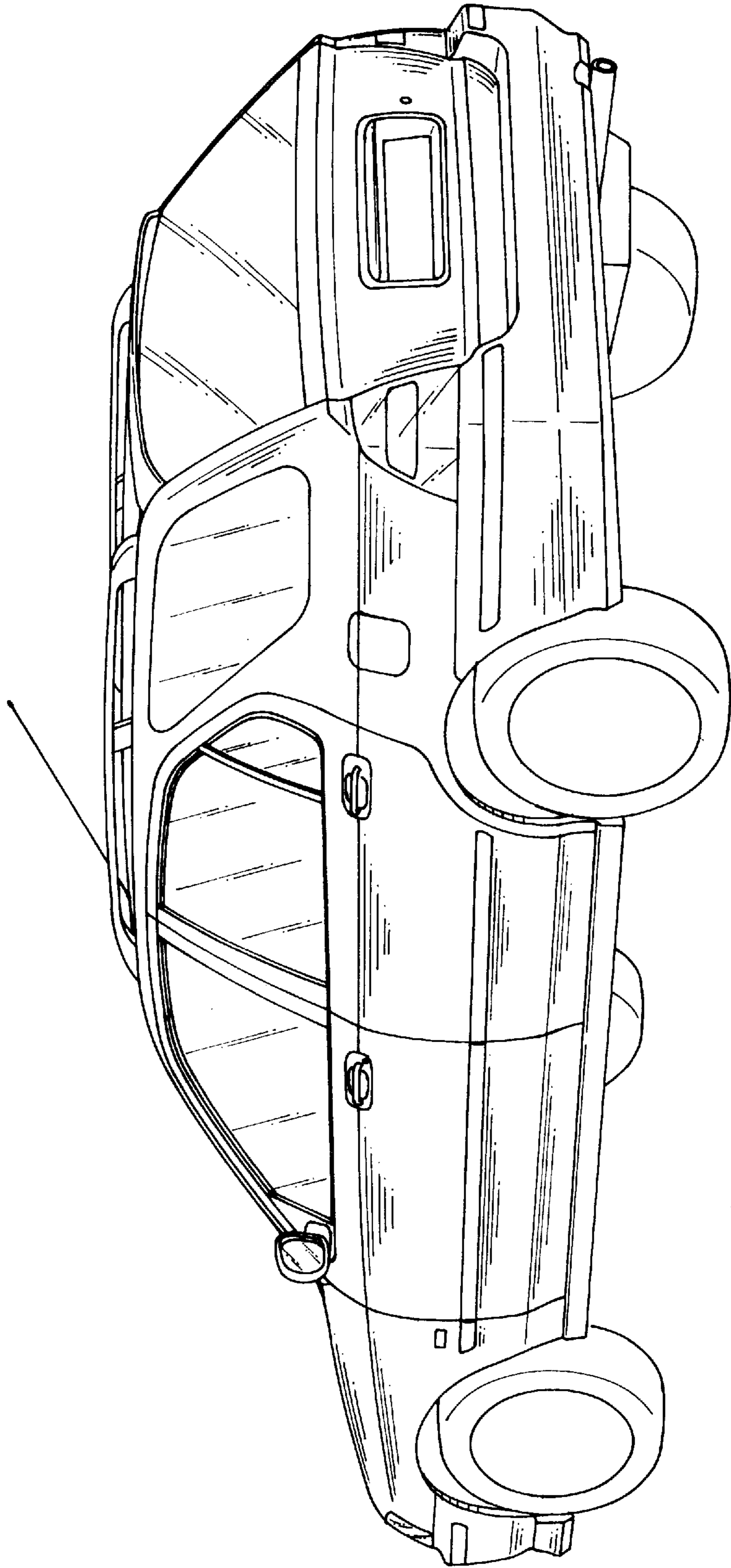

FIG. 3

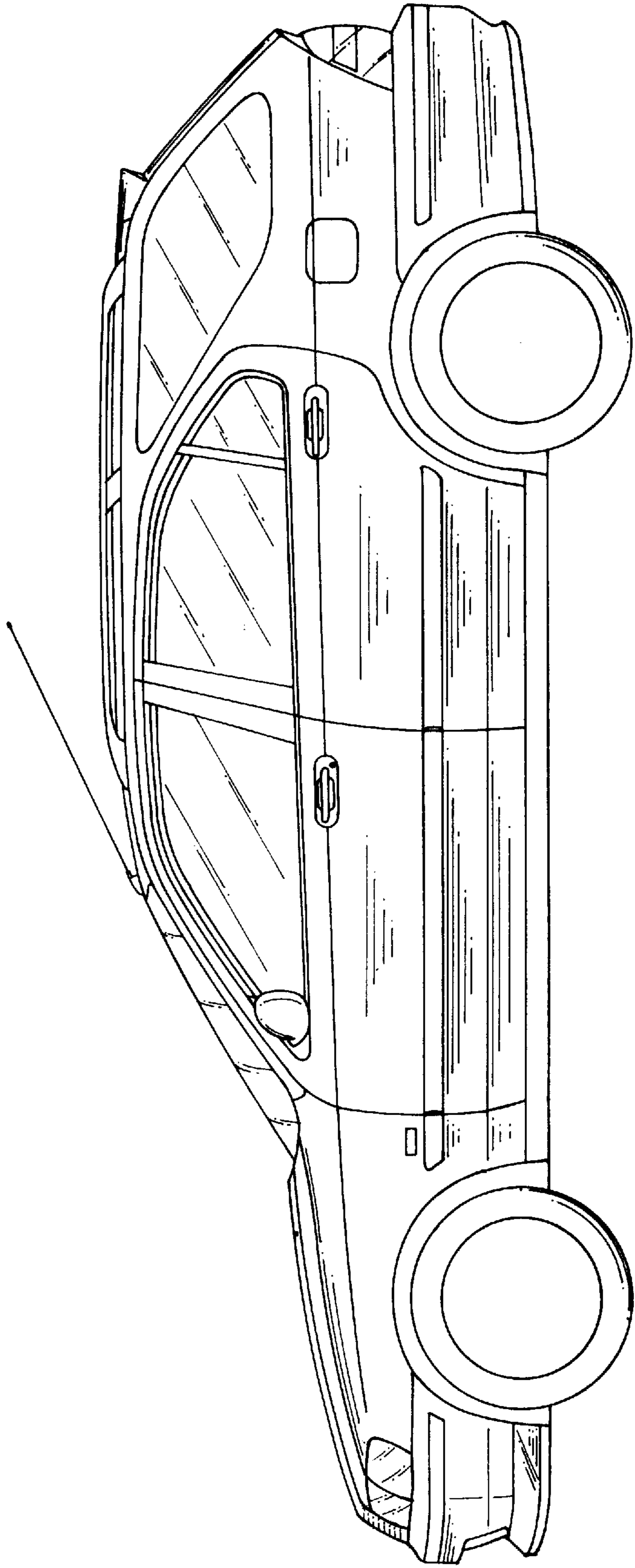

FIG. 4

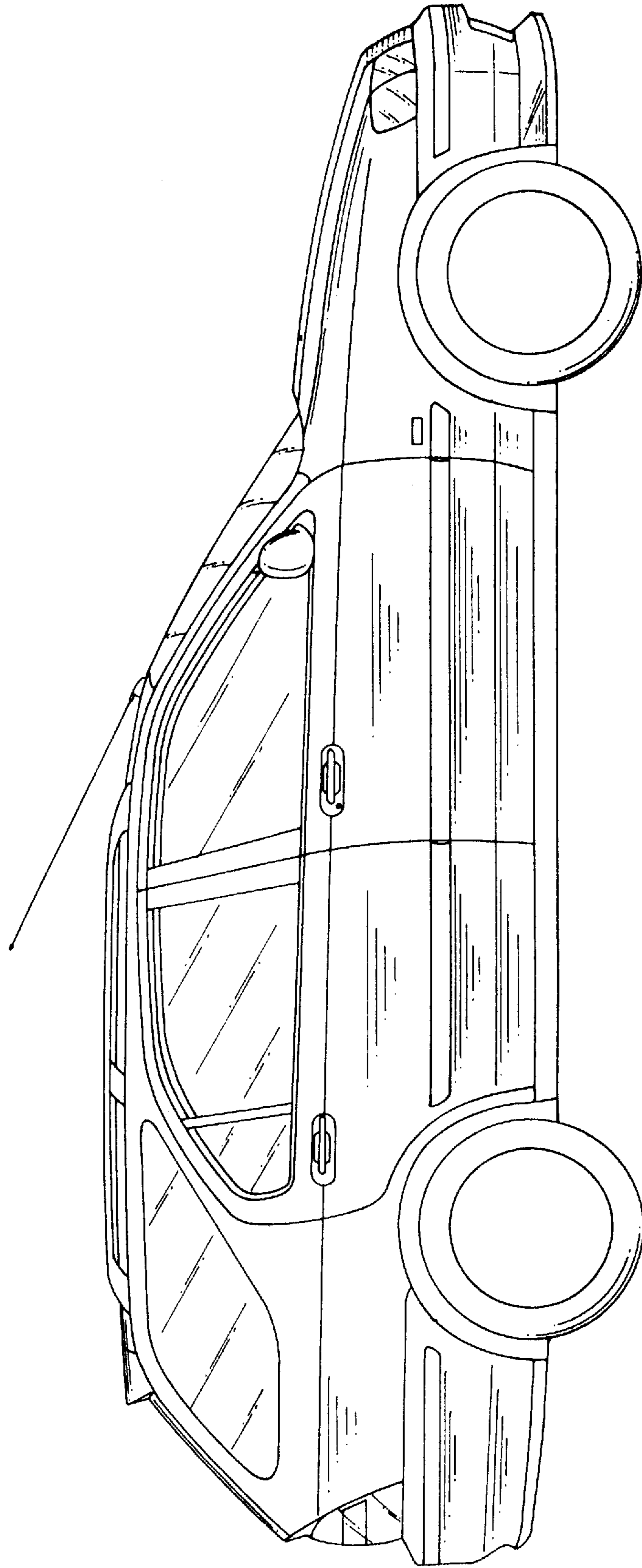

FIG. 6

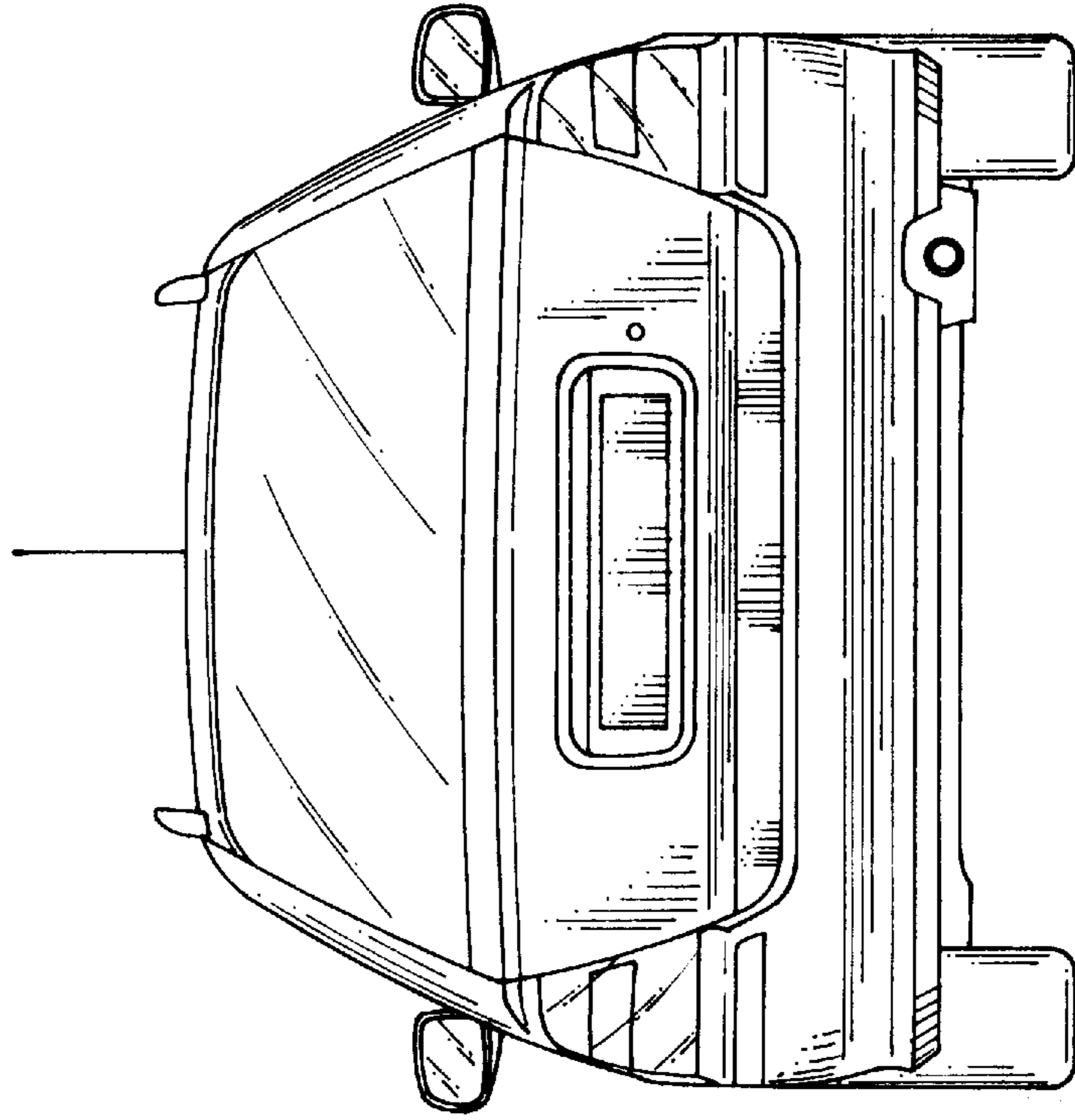

FIG. 5

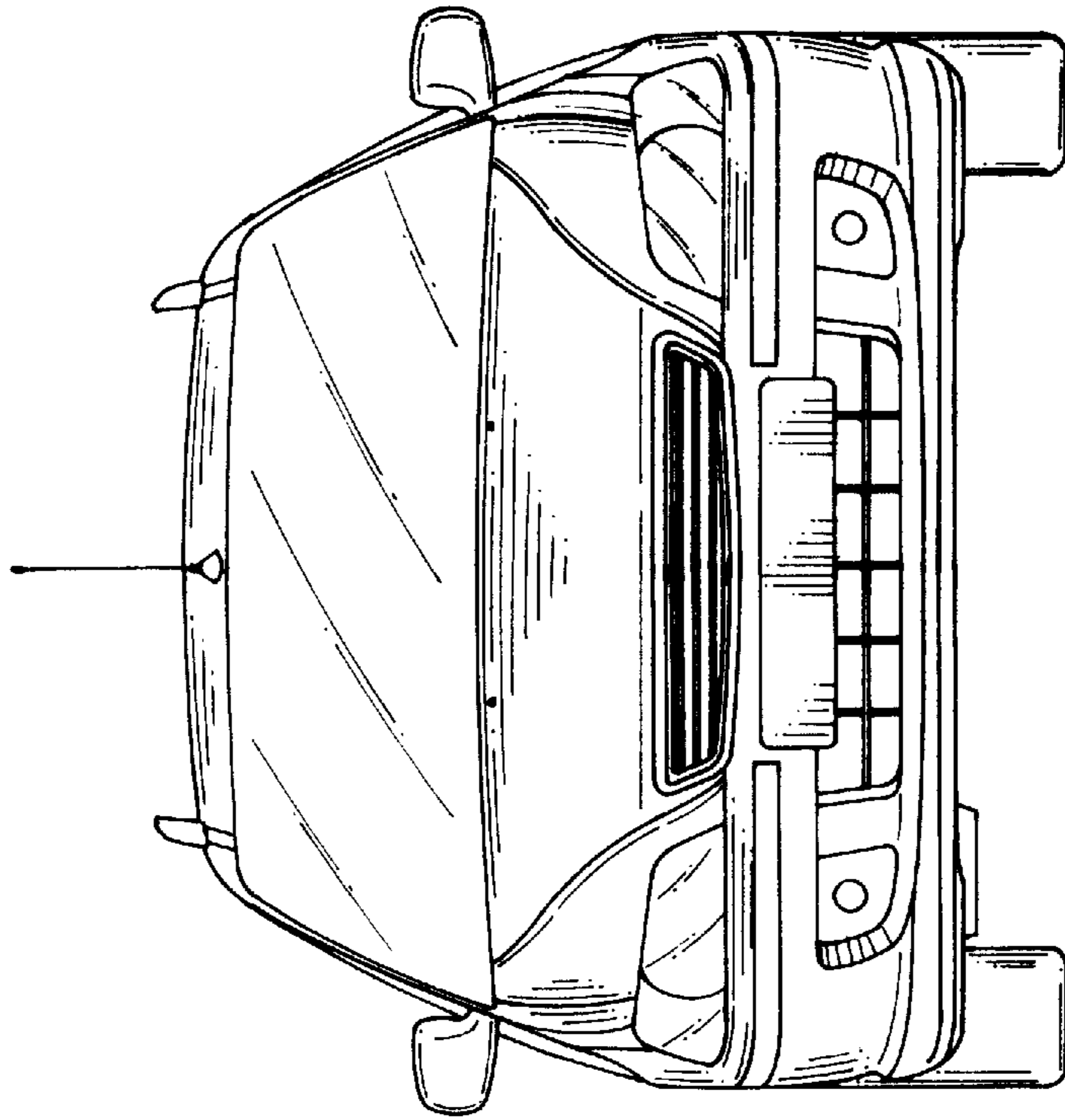

FIG. 7

