



US00D407169S

United States Patent [19]
Otto

[11] **Patent Number: Des. 407,169**

[45] **Date of Patent: **Mar. 23, 1999**

[54] **HEADLAMP**

Primary Examiner—Marcus A. Jackson
Attorney, Agent, or Firm—Fredrikson & Byron, P.A.

[75] Inventor: **David Otto**, Dresser, Wis.

[73] Assignee: **Polaris Industries, Inc.**, Osceola, Wis.

[57] **CLAIM**

[**] Term: **14 Years**

I claim the ornamental design for a headlamp, as shown and described.

[21] Appl. No.: **88,890**

[22] Filed: **Jun. 3, 1998**

DESCRIPTION

[51] **LOC (6) Cl.** **26-06**

[52] **U.S. Cl.** **D26/28**

[58] **Field of Search** D26/28–36; 362/72,
362/157, 158, 183, 189, 191, 192, 193,
194, 196, 200–206, 208

FIG. 1 is a perspective view as seen from the front and top and one side of the design;

FIG. 2 is a top plan view thereof;

FIG. 3 is a front elevation view thereof;

FIG. 4 is a side elevation view as seen from the side opposite that shown in FIG. 1;

FIG. 5 is a side elevation view as seen from the side opposite that shown in FIG. 4;

FIG. 6 is a rear elevation view thereof; and,

FIG. 7 is a bottom plan view thereof.

[56] **References Cited**

U.S. PATENT DOCUMENTS

D. 333,879	3/1993	Jsai	D26/28
D. 353,682	12/1994	Ueda	D26/28
D. 382,356	8/1997	Okuda et al.	D26/28
D. 383,277	9/1997	Nagano	D26/28
D. 393,086	3/1998	Nagano	D26/28

OTHER PUBLICATIONS

Hugo Wilson, *The Encyclopedia of the Motorcycle*, 1995, cover, copyright page, table of contents page, and pp. 16, 30, 34, 112, 133, 137, 139, 141, 150, 174, 175, 192, 200, and 208 prior to Jun. 3, 1998.

1 Claim, 4 Drawing Sheets

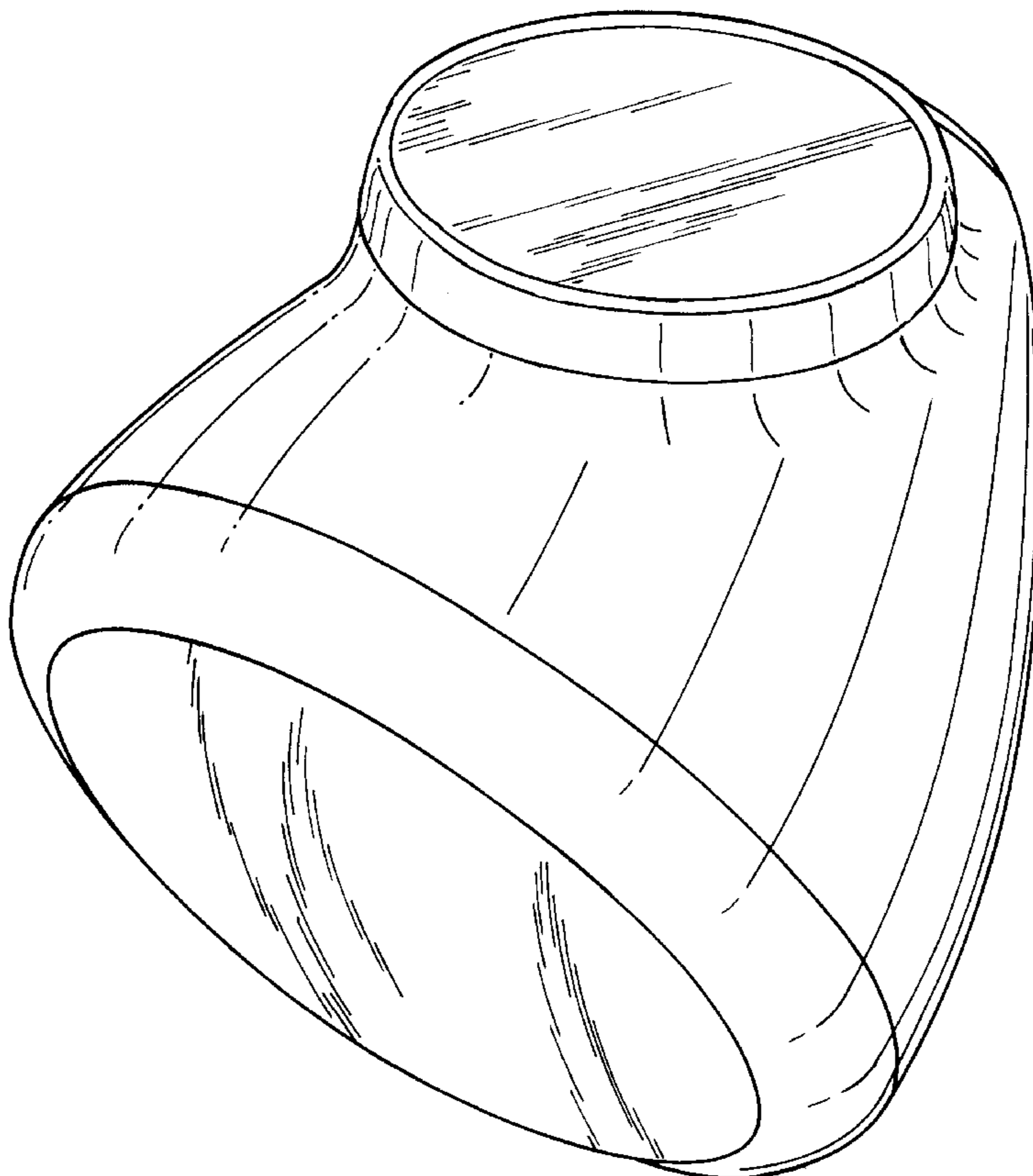

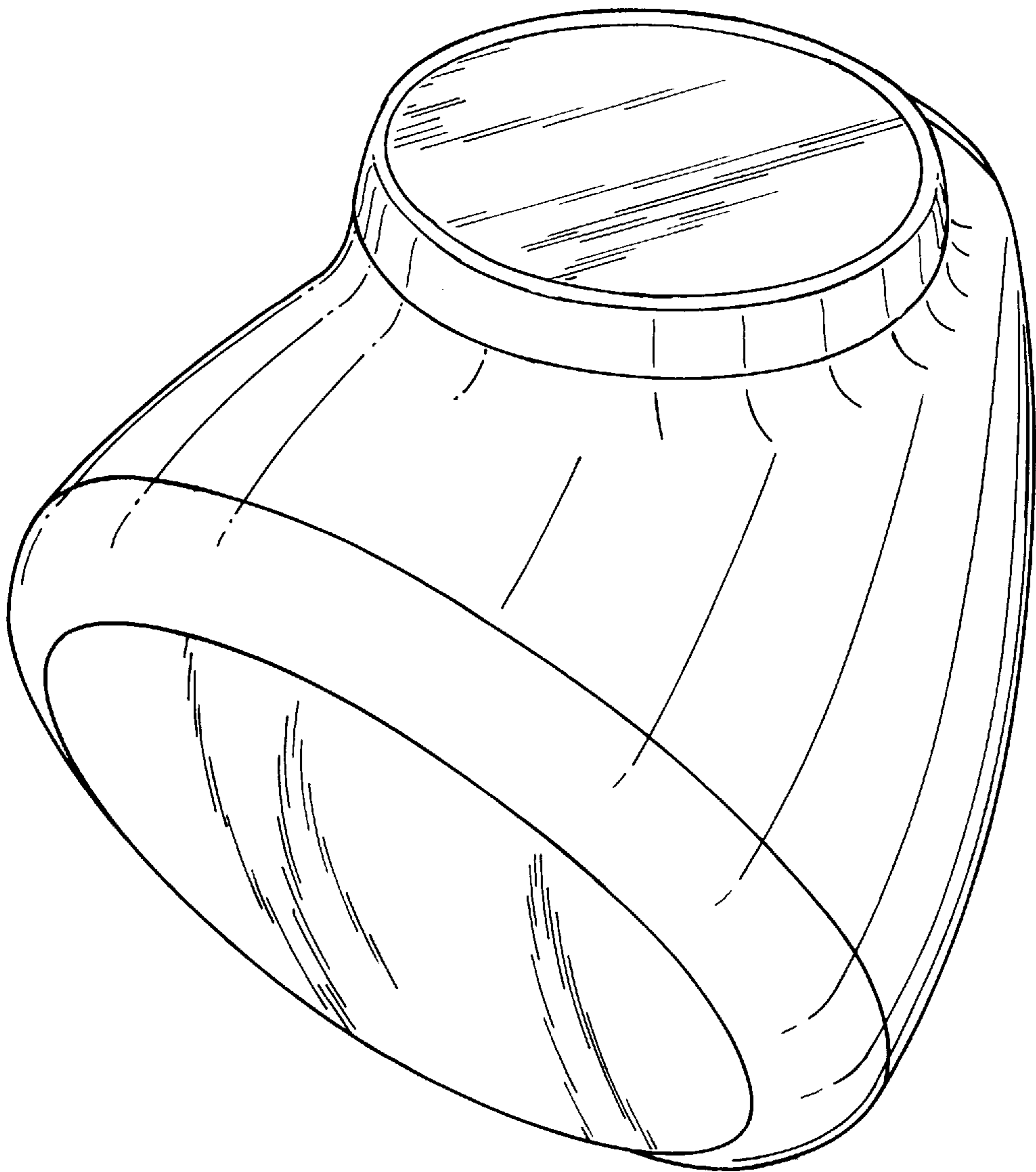

Fig. 1

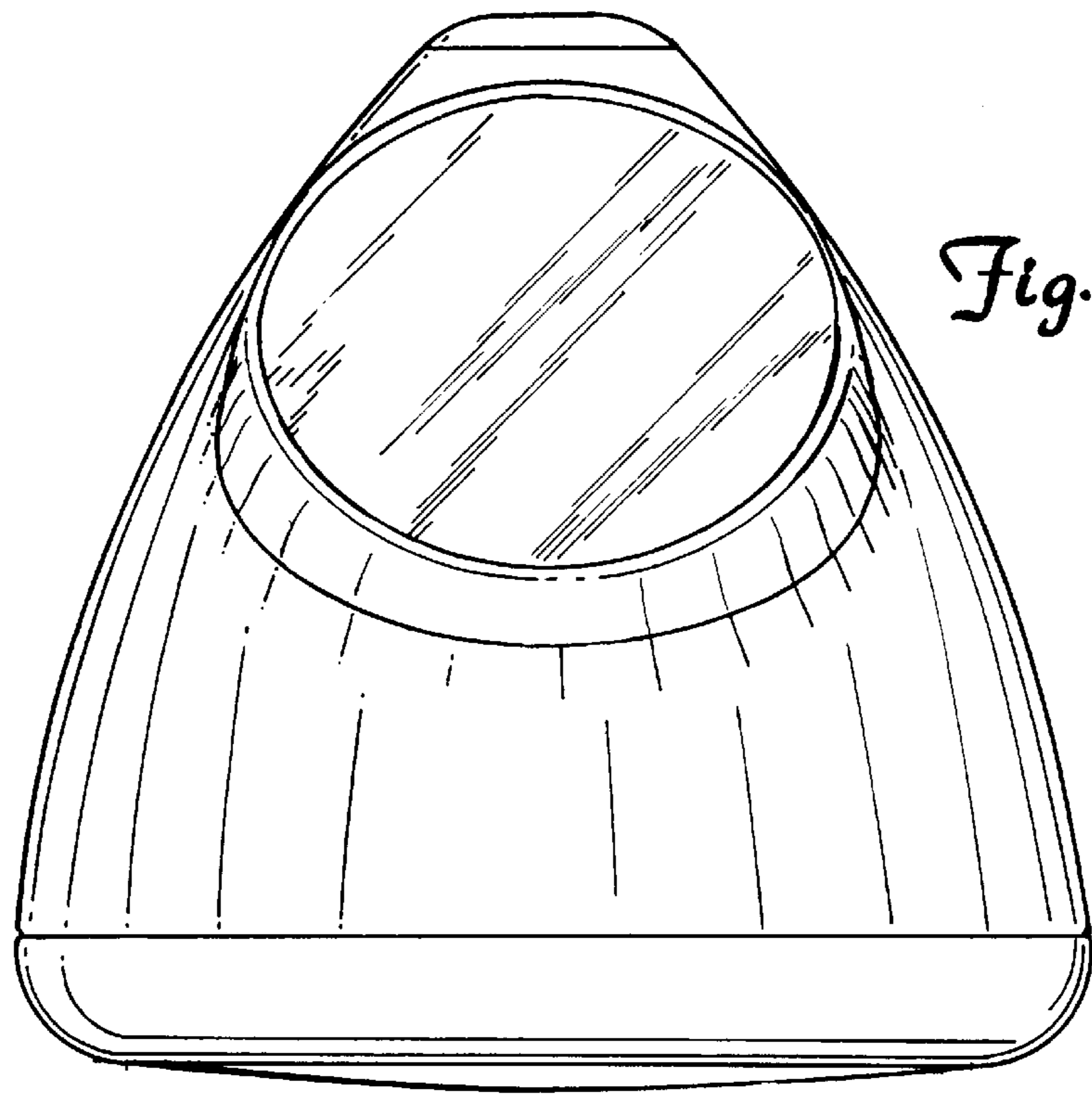

Fig. 2

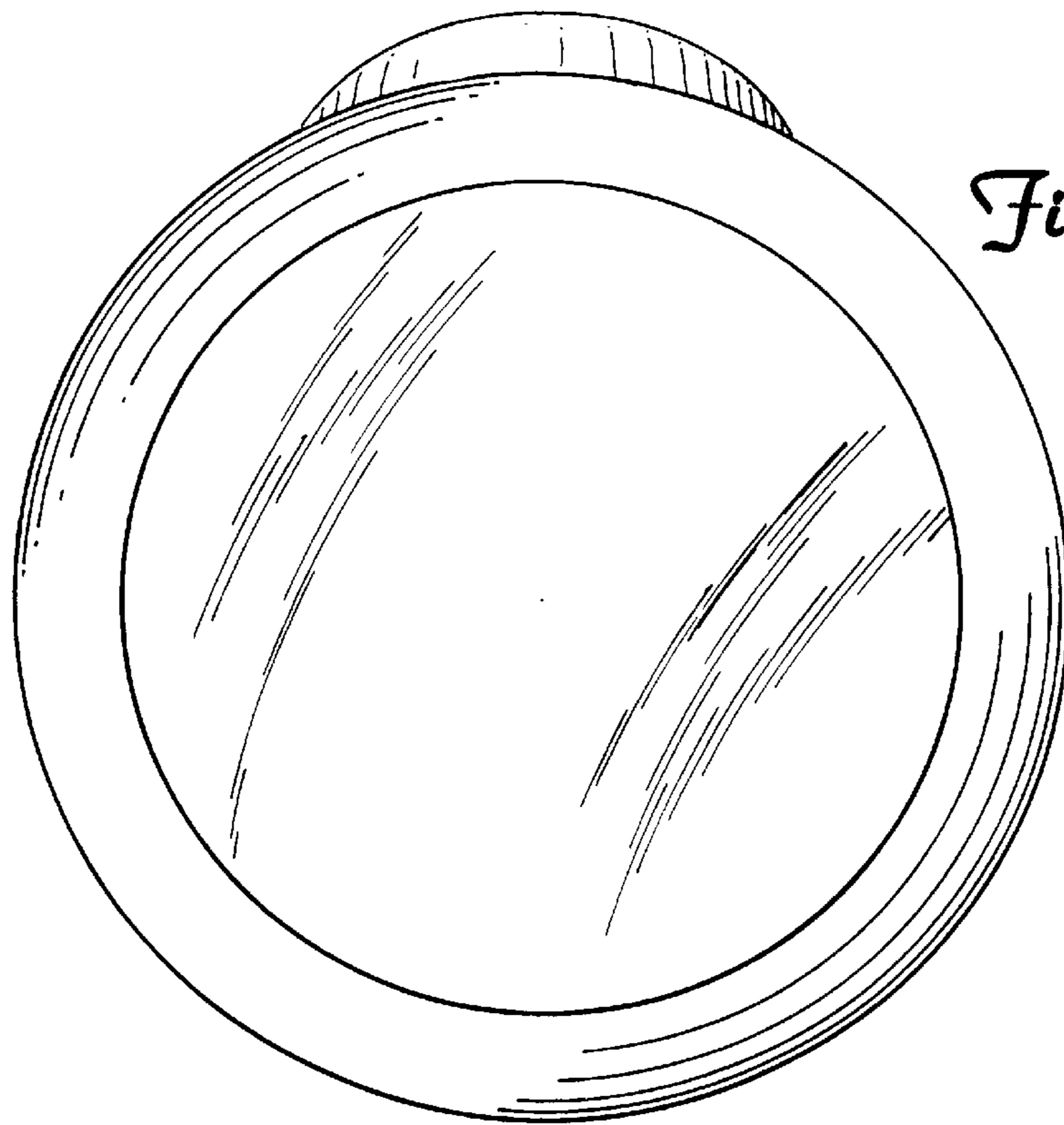

Fig. 3

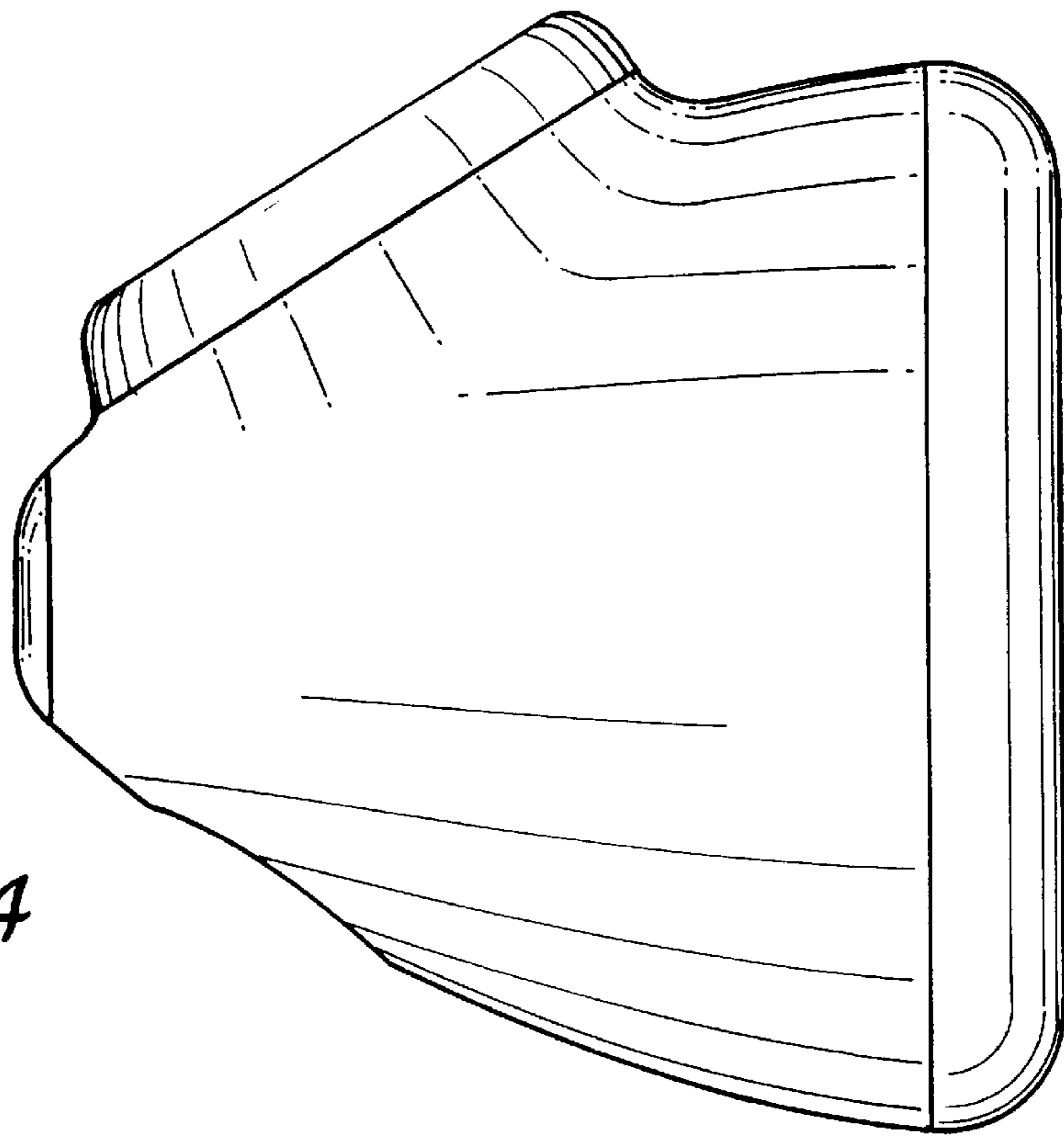

Fig. 4

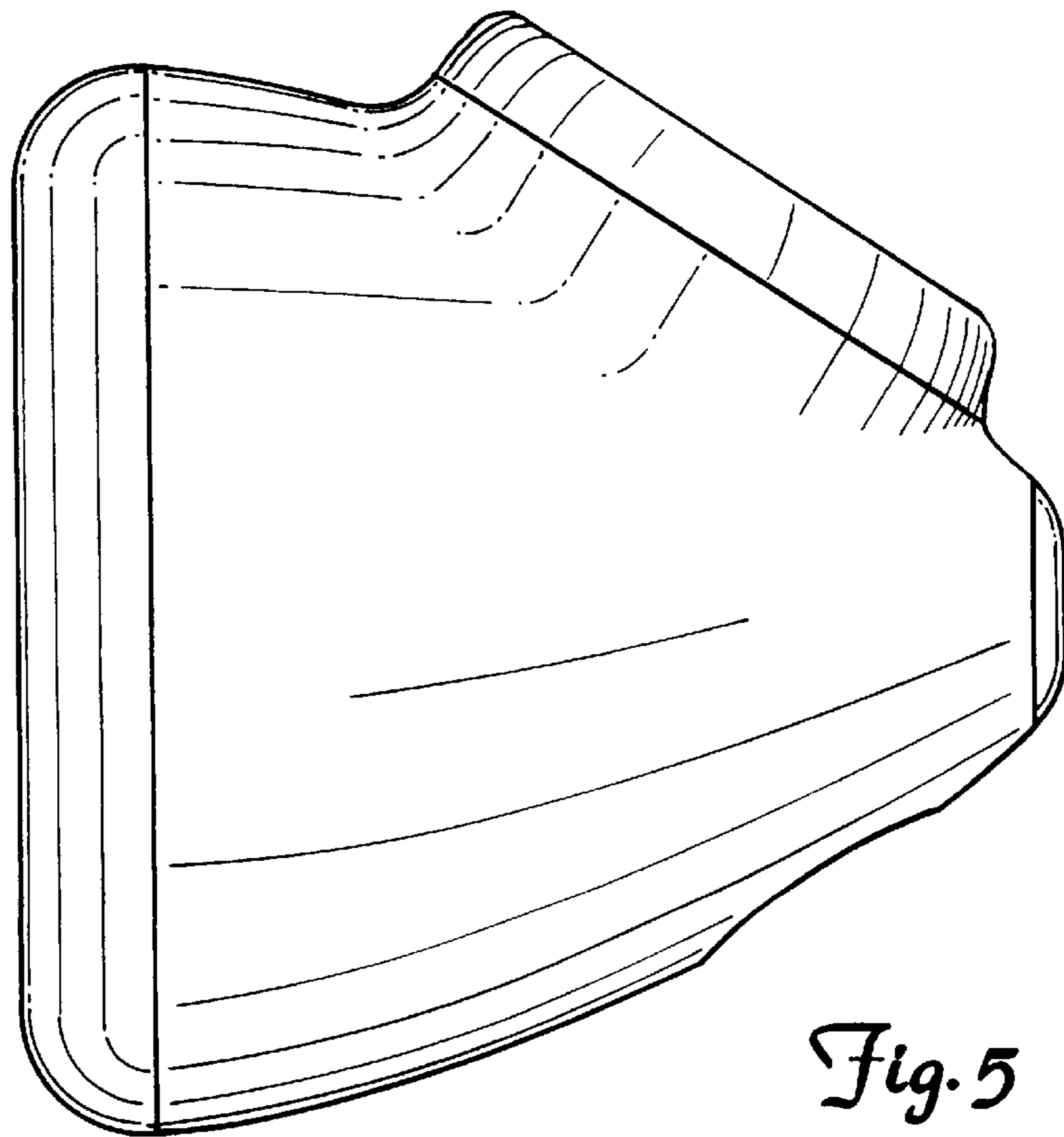

Fig. 5

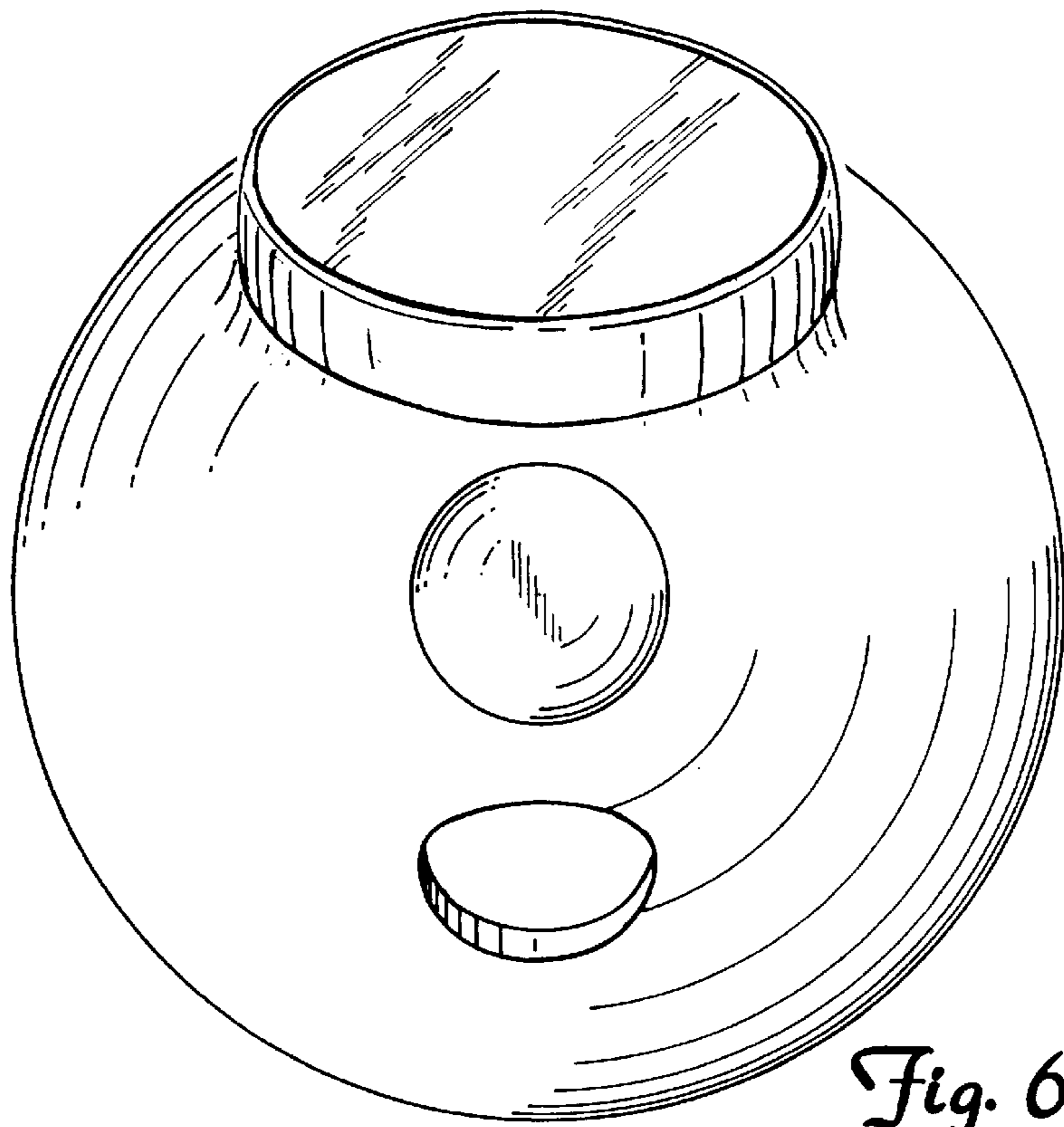

Fig. 6

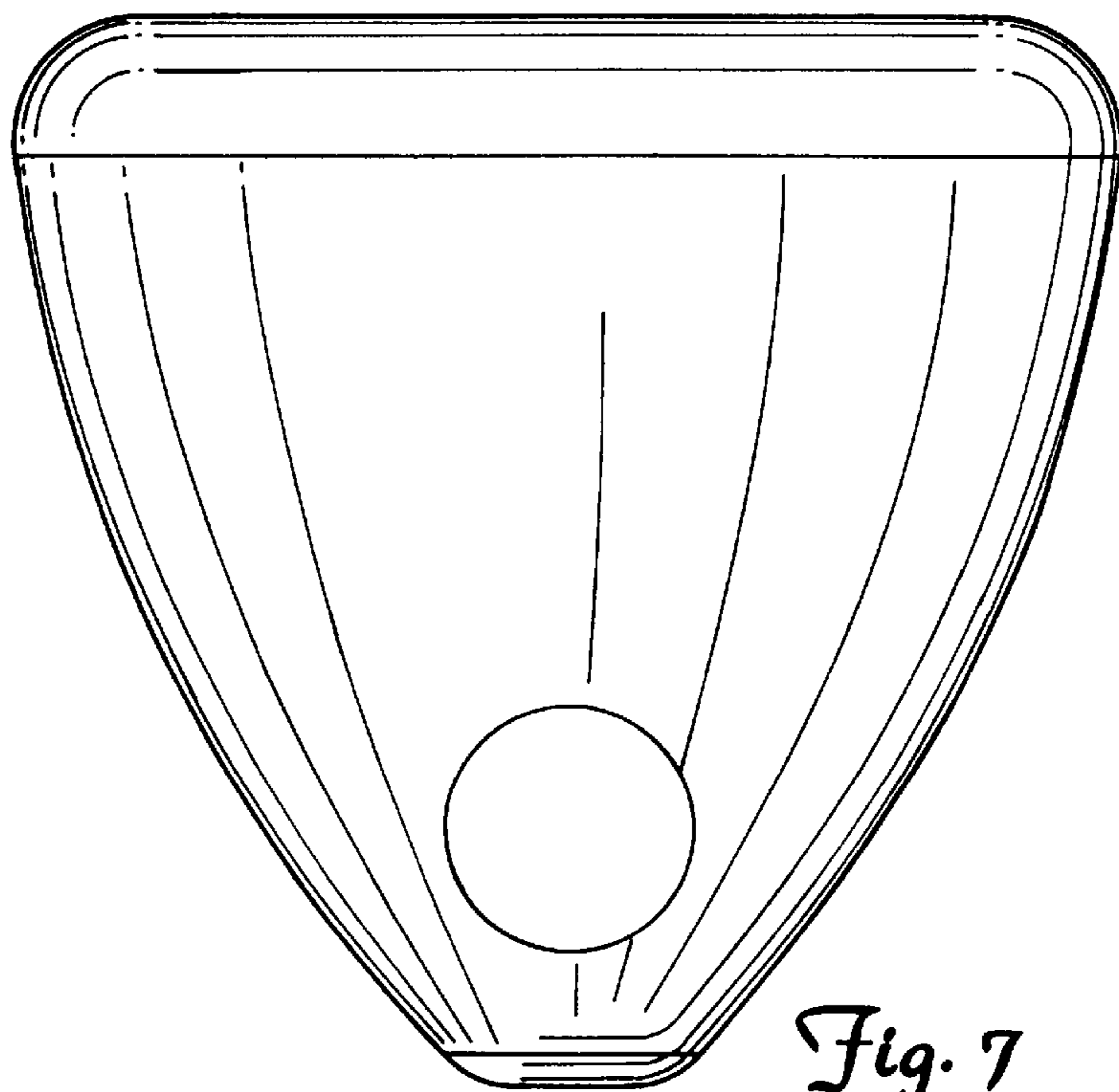

Fig. 7