



US00D407075S

United States Patent [19] Wung

[11] Patent Number: **Des. 407,075**

[45] Date of Patent: ****Mar. 23, 1999**

[54] **VEHICLE MOUNTED TERMINAL**

[75] Inventor: **Peter Wung**, Redmond, Wash.

[73] Assignee: **Intermec Technologies Corporation**, Everett, Wash.

[**] Term: **14 Years**

[21] Appl. No.: **80,750**

[22] Filed: **Dec. 15, 1997**

[51] **LOC (6) Cl.** **14-02**

[52] **U.S. Cl.** **D14/100; D12/192; D12/400**

[58] **Field of Search** D14/100, 106, D14/101, 113, 115; D12/400, 415, 192, 418; 235/145 A, 145 R; 345/104, 156, 168, 173, 901-905, 87; 341/22, 23; 361/680-686; 364/708.1; 312/7.1; D10/65, 46; 340/990, 995, 996; 353/12; 248/917-924, 183.2

[56] **References Cited**

U.S. PATENT DOCUMENTS

D. 302,540	8/1989	Arenas et al.	D12/400
D. 321,340	11/1991	Savio	D14/100
D. 332,943	2/1993	Koiwa et al.	D14/105
D. 349,487	8/1994	Horner et al.	D14/100
D. 364,840	12/1995	Oshizawa et al.	D12/192
D. 373,116	8/1996	Werse	D14/100
4,312,577	1/1982	Fitzgerald	353/12
4,946,120	8/1990	Hatcher	248/183.2

Primary Examiner—Freda Nunn
Attorney, Agent, or Firm—Joan H. Pauly

[57] **CLAIM**

The ornamental design for a vehicle mounted terminal, shown and described.

DESCRIPTION

FIG. 1 is a perspective view of the vehicle mounted terminal with the bracket and terminal in relative positions for mounting the terminal on a horizontal surface; FIG. 2 is a front elevational view thereof; FIG. 3 is a rear elevational view thereof; FIG. 4 is a left side elevational view thereof, the right side elevational view being a mirror image of the left side elevational view; FIG. 5 is a top plan view thereof; FIG. 6 is a bottom plan view thereof; FIG. 7 is a perspective view like FIG. 1 except that it shows the keyboard portion of the terminal in a different pivot position relative to the display portion of the terminal; FIG. 8 is a front elevational view of the vehicle mounted terminal as shown in FIG. 7; FIG. 9 is a side elevational view of the vehicle mounted terminal as shown in FIGS. 7 and 8; and, FIGS. 10-15 are like FIGS. 1-6, respectively, except that they show the bracket connected to and pivoted relative to the terminal in a position for mounting the terminal to an overhead structure.

1 Claim, 8 Drawing Sheets

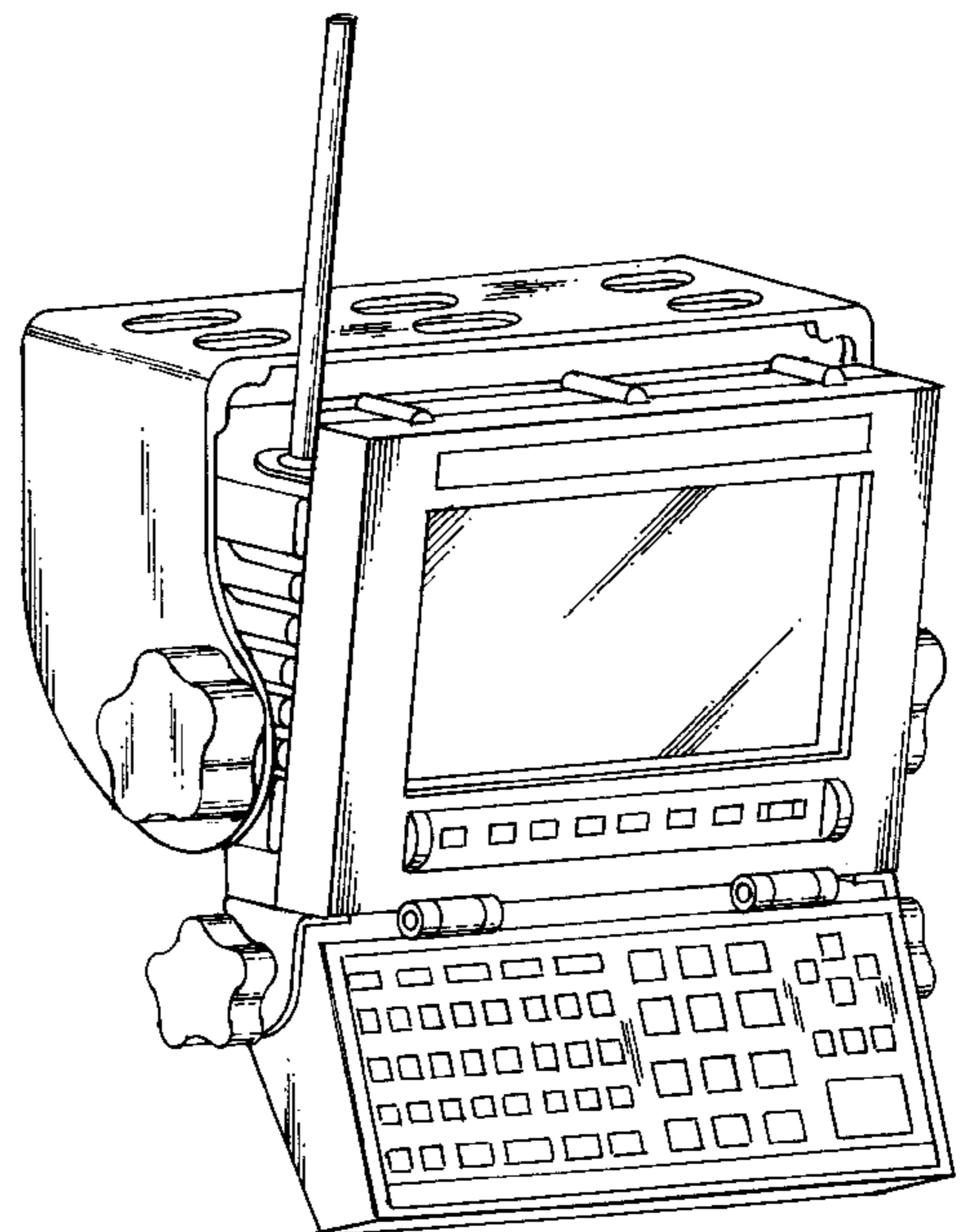
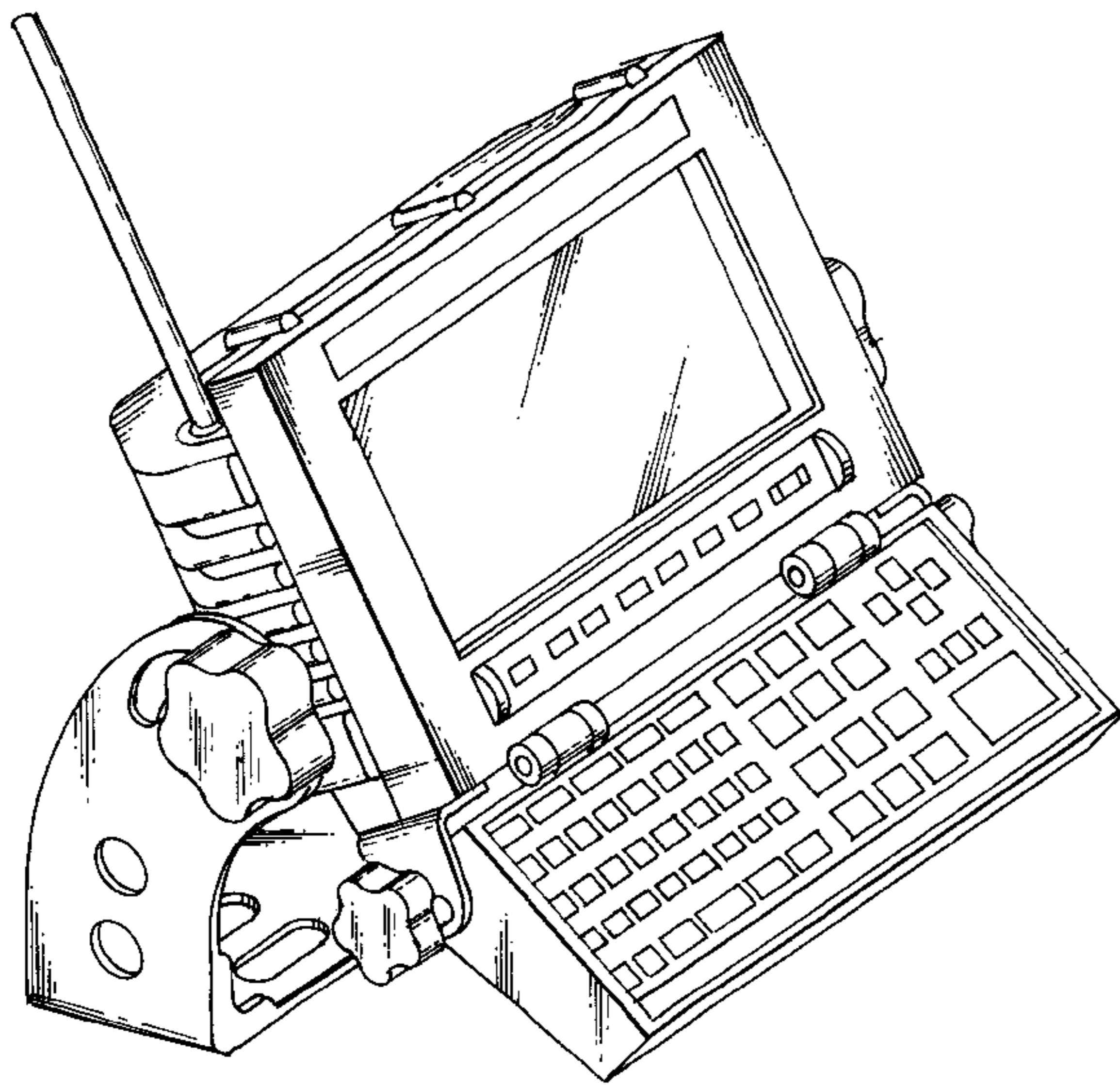

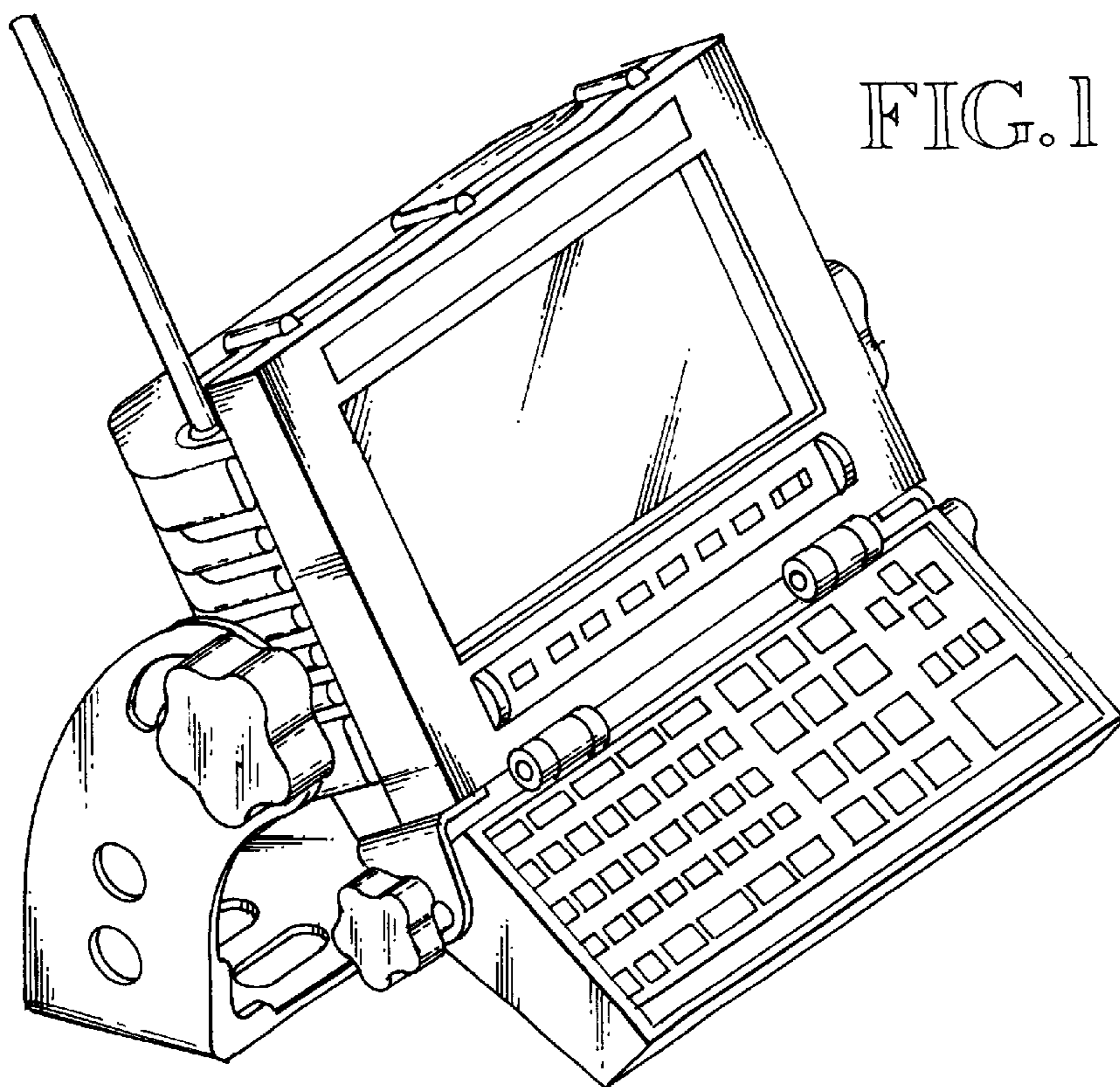

FIG. 1

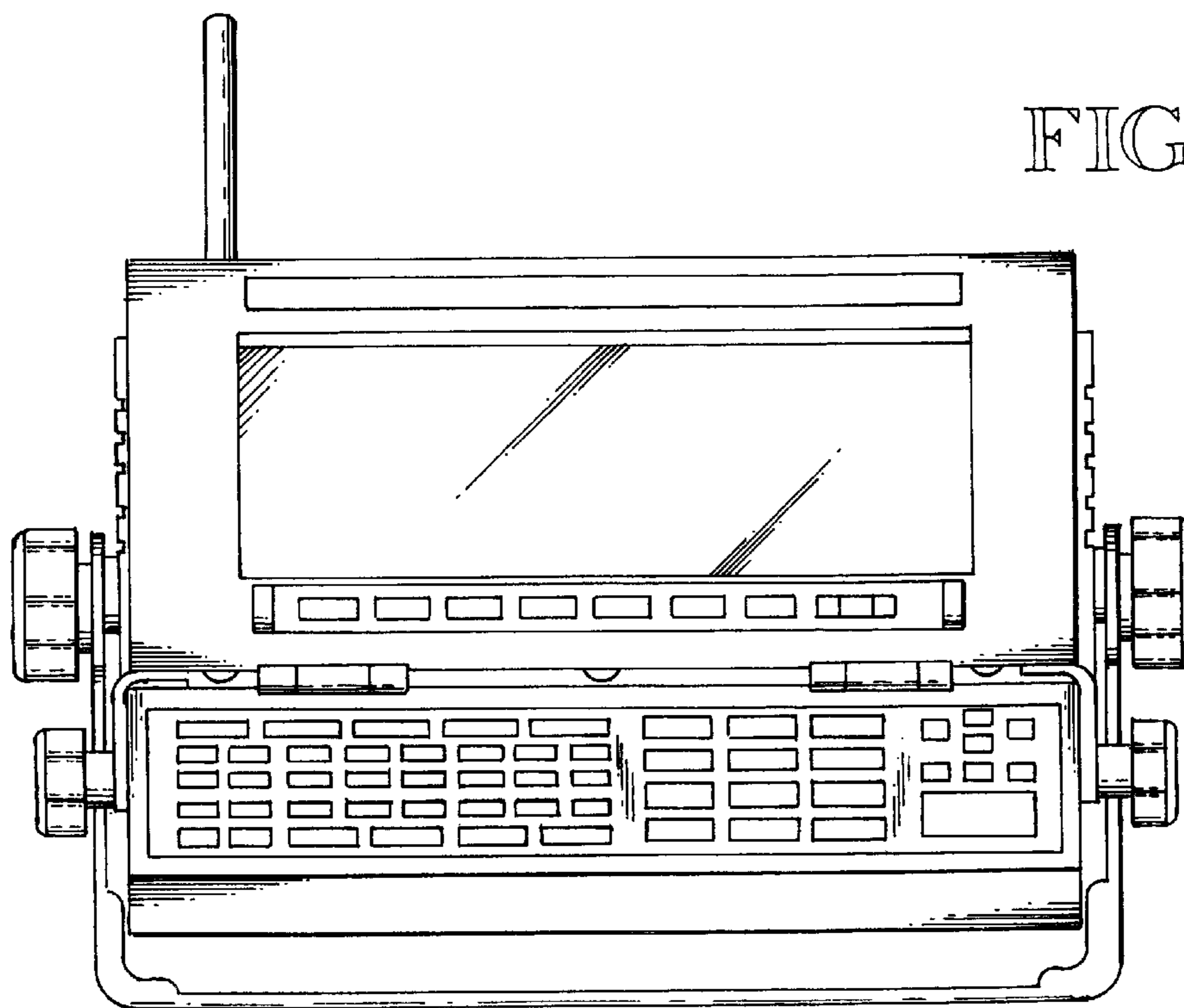

FIG. 2

FIG. 3

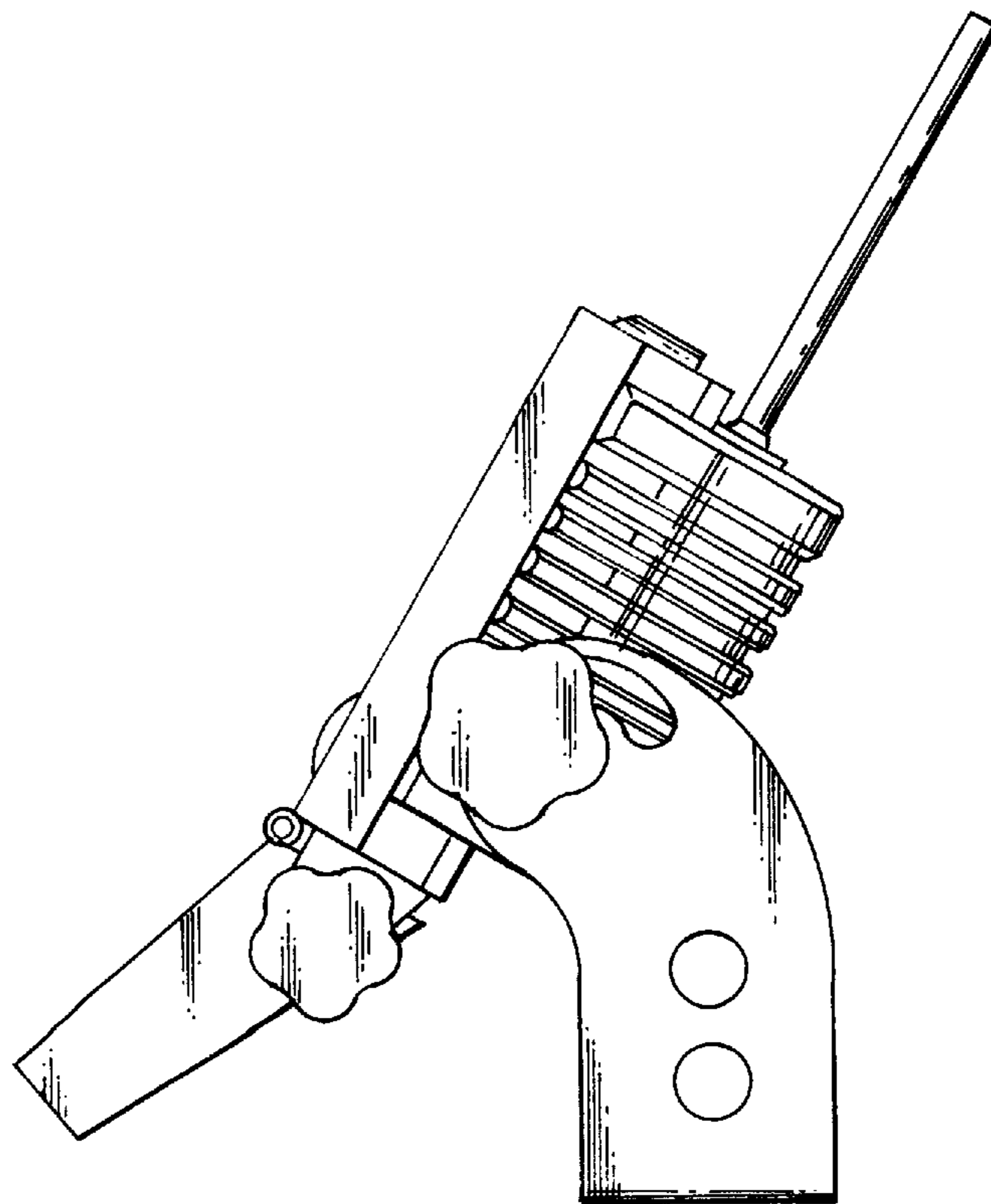
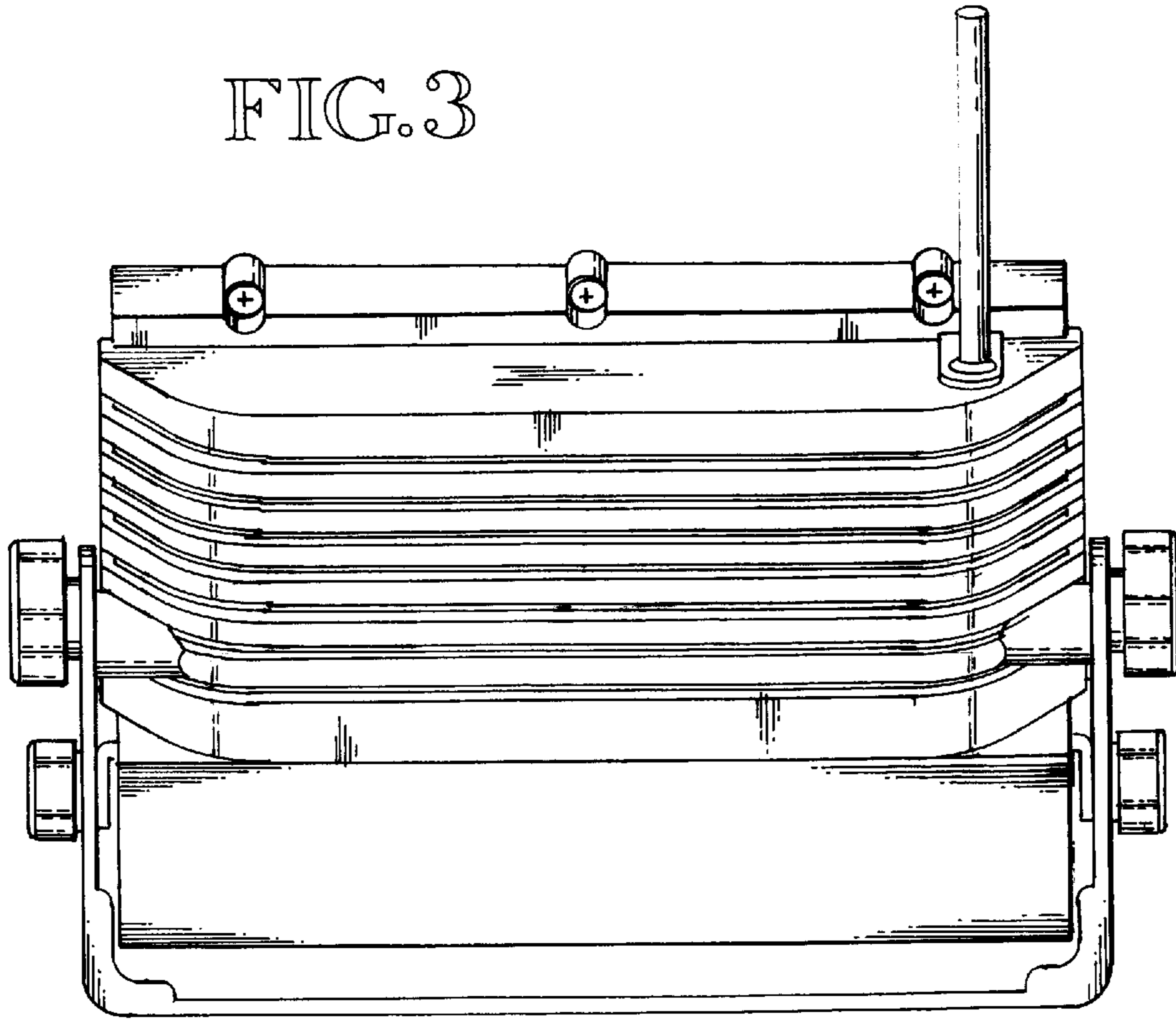

FIG. 4

FIG. 5

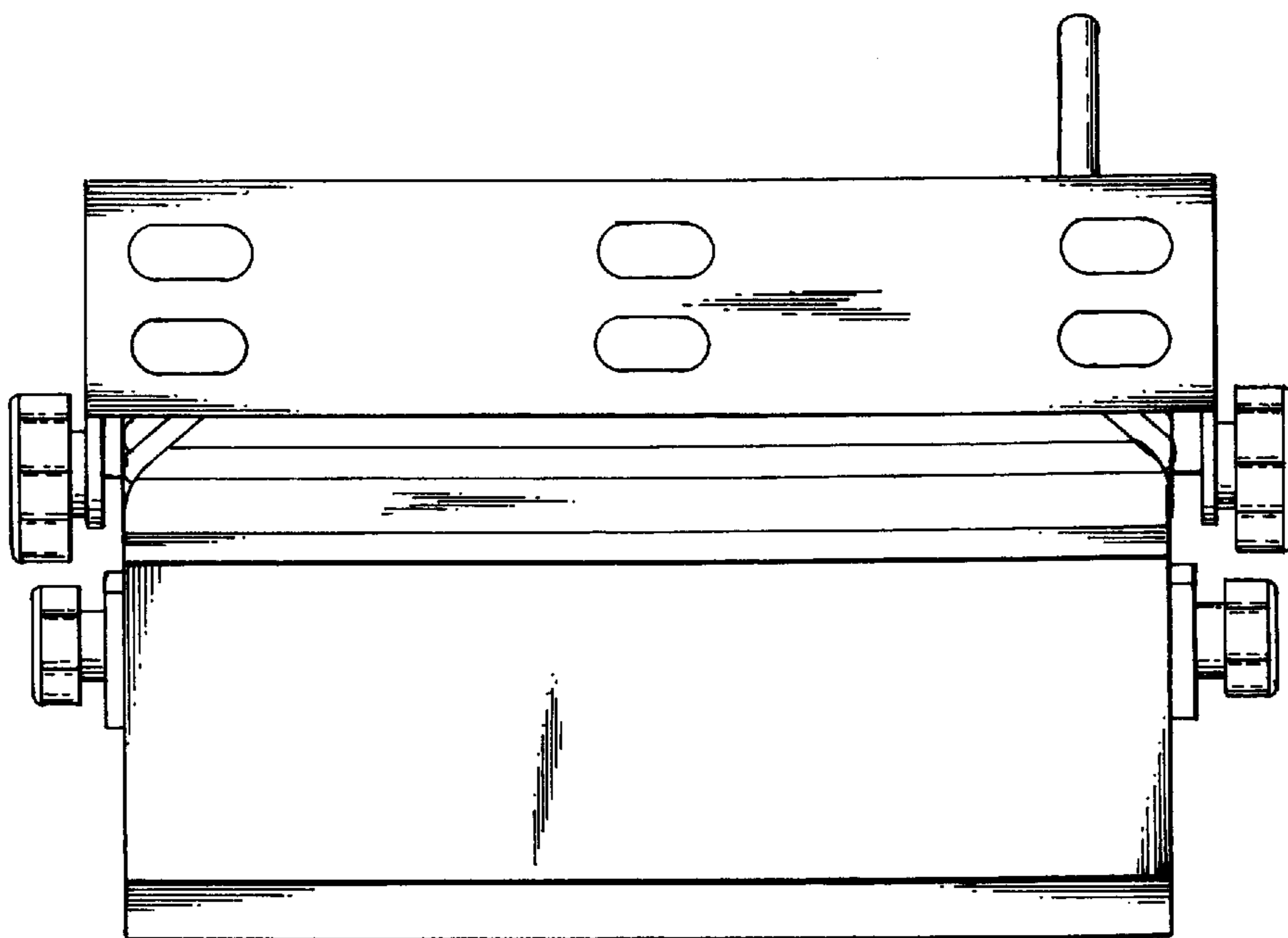
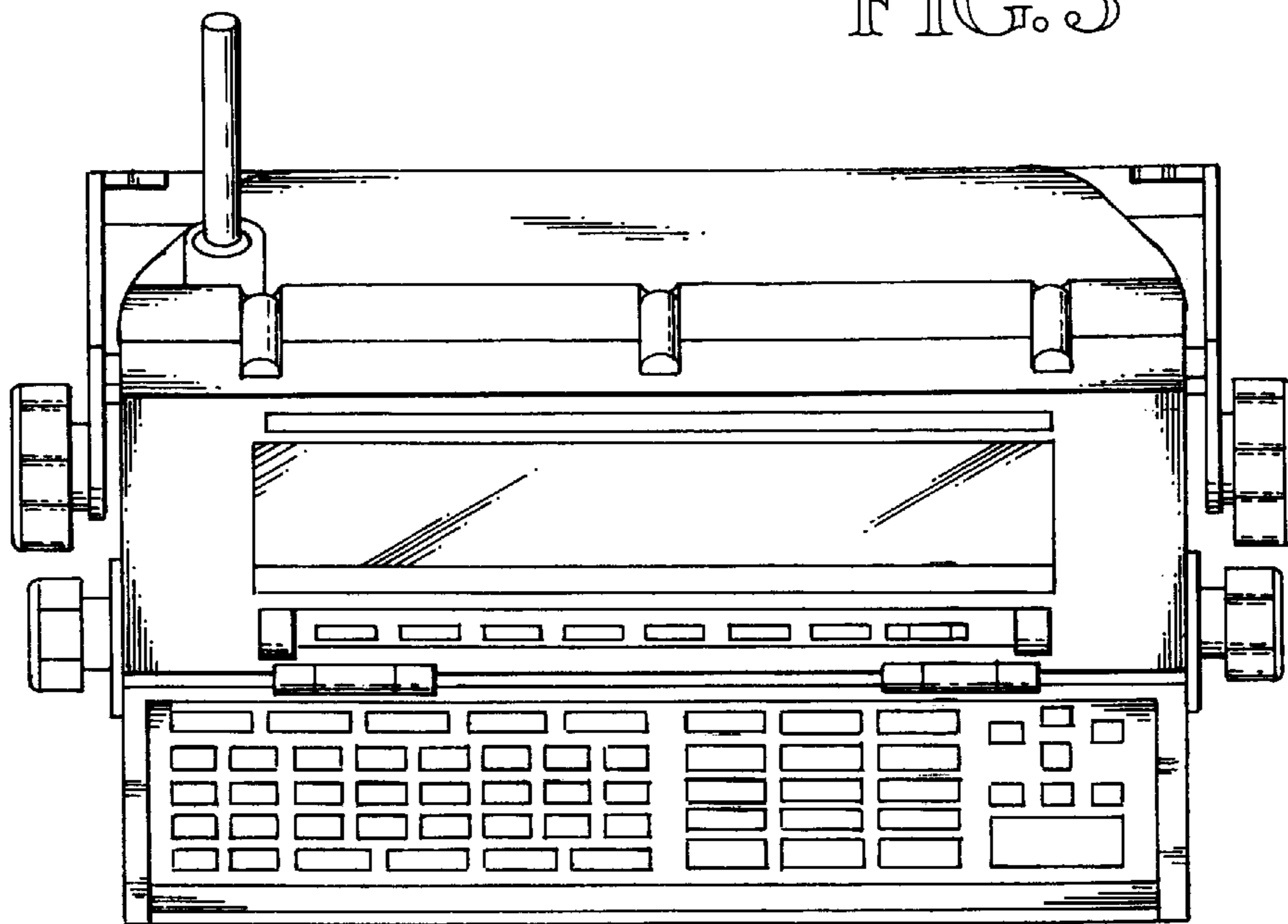

FIG. 6

FIG. 7

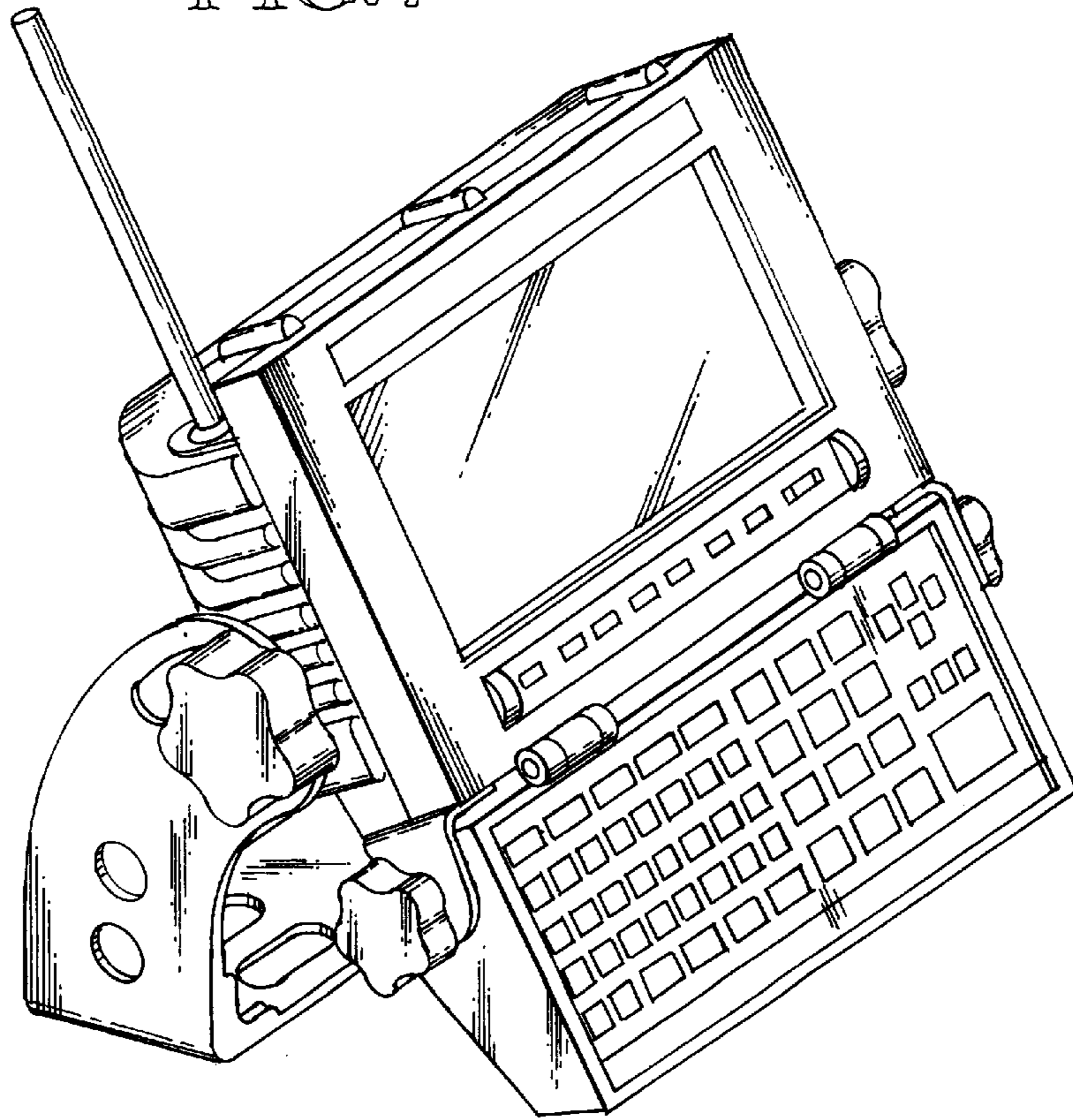

FIG. 8

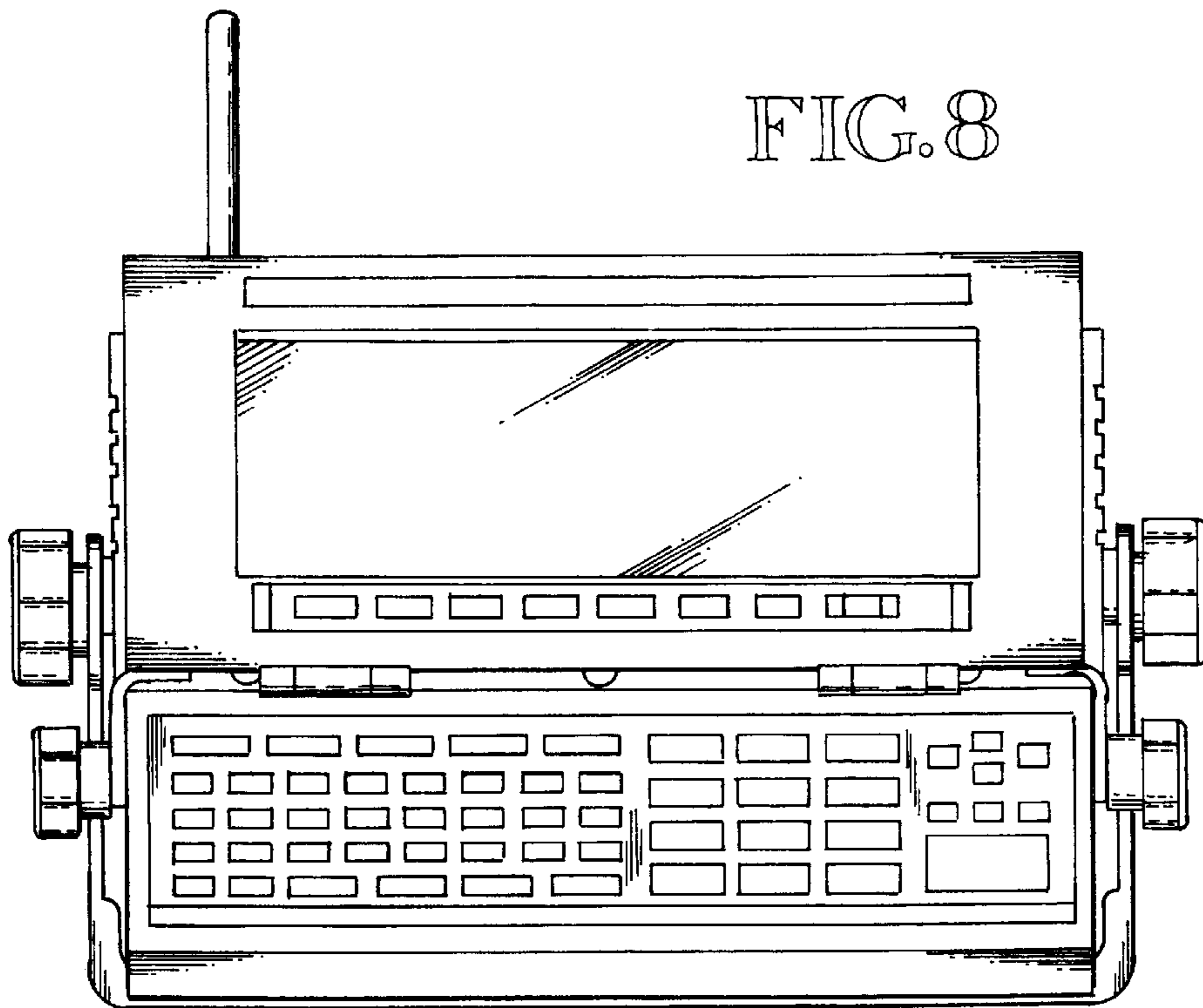

FIG. 9

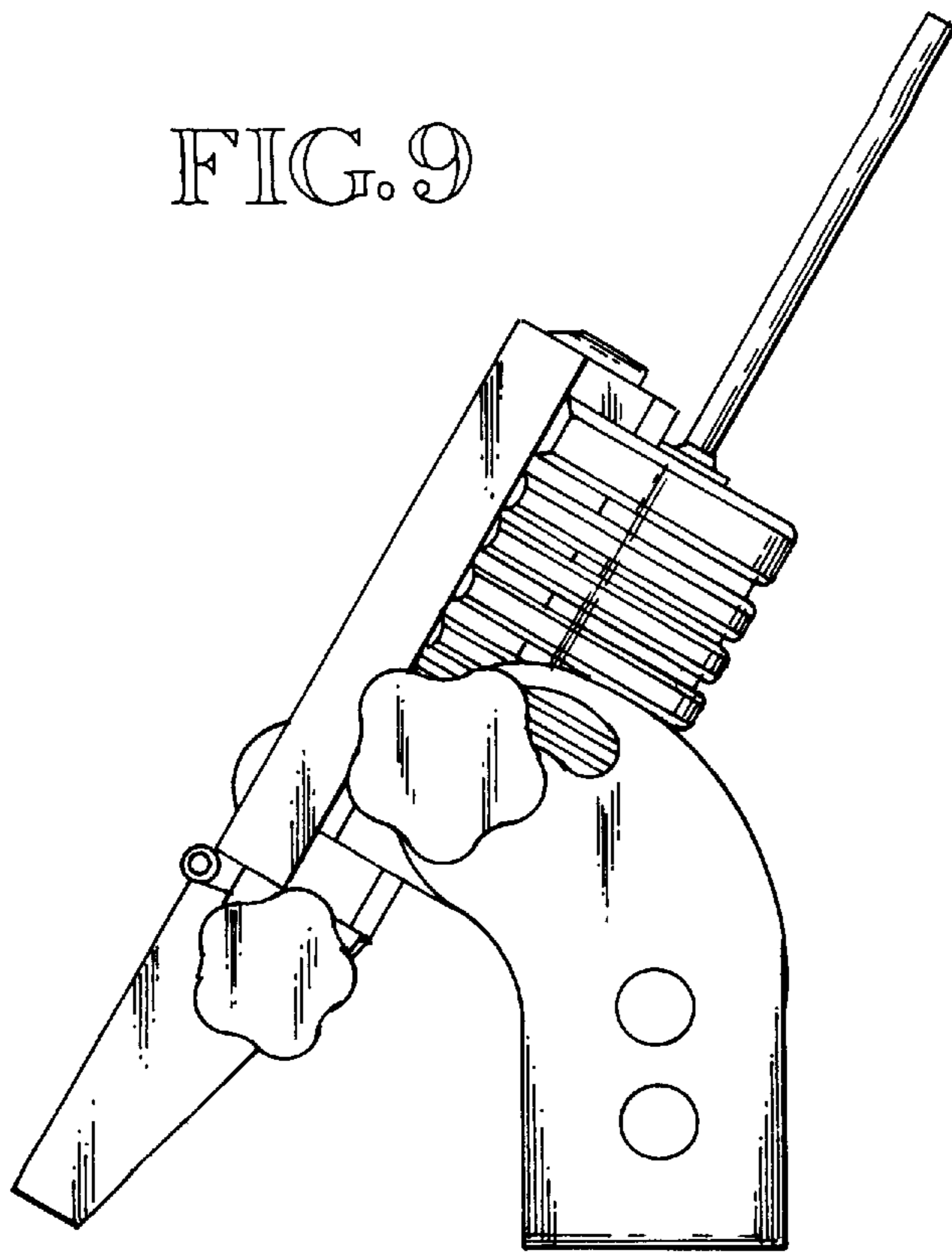

FIG. 10

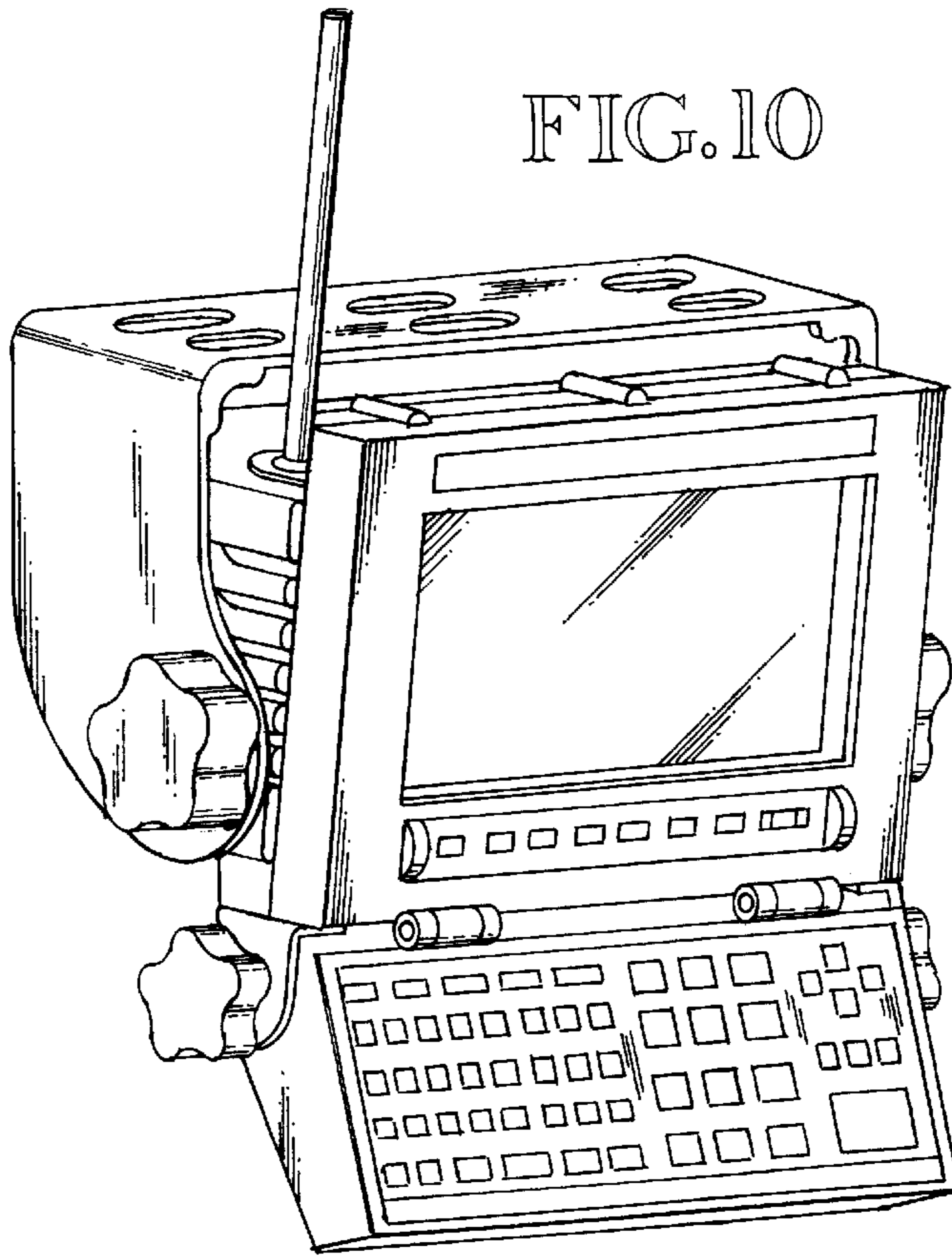

FIG. 11

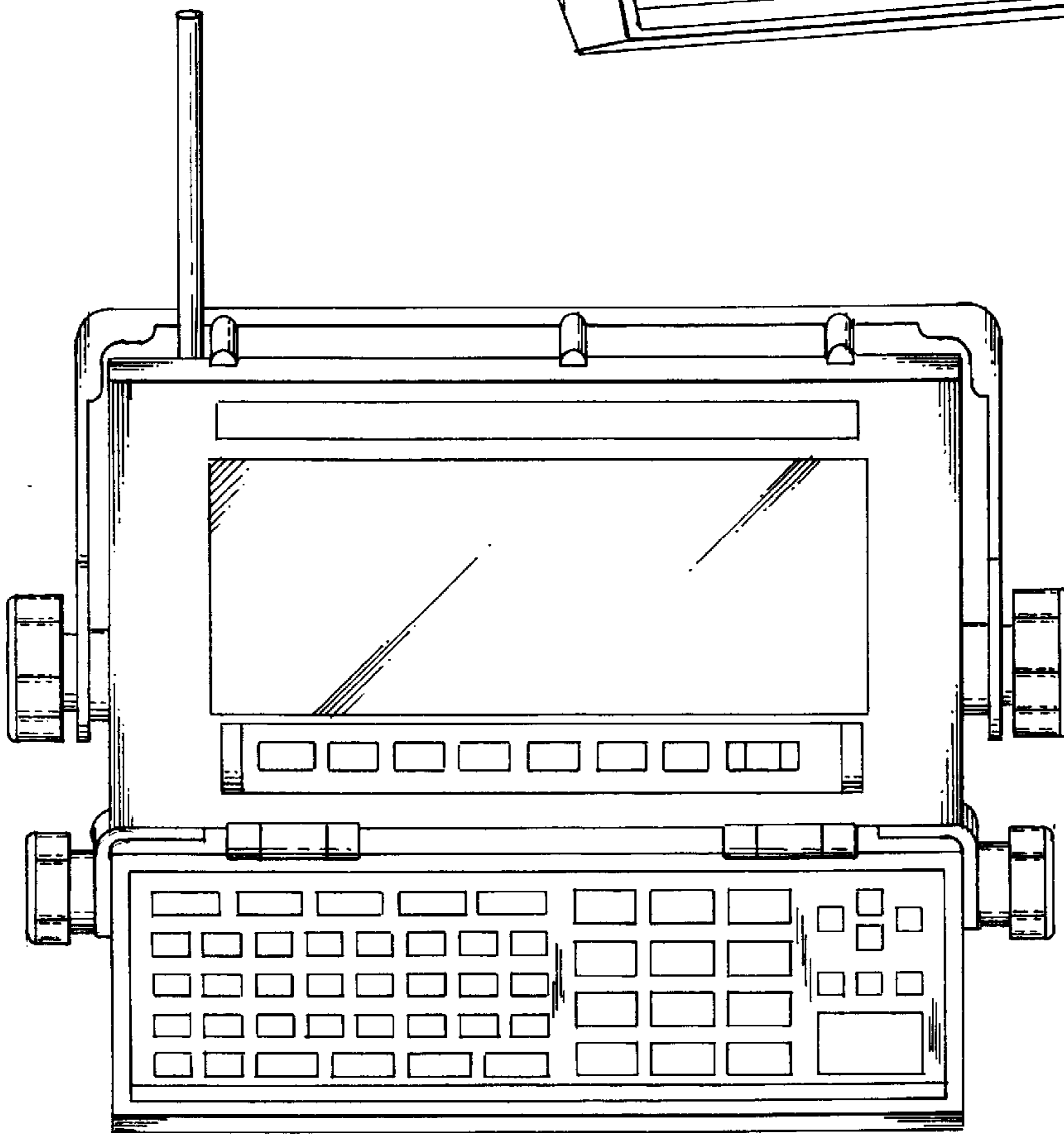

FIG. 12

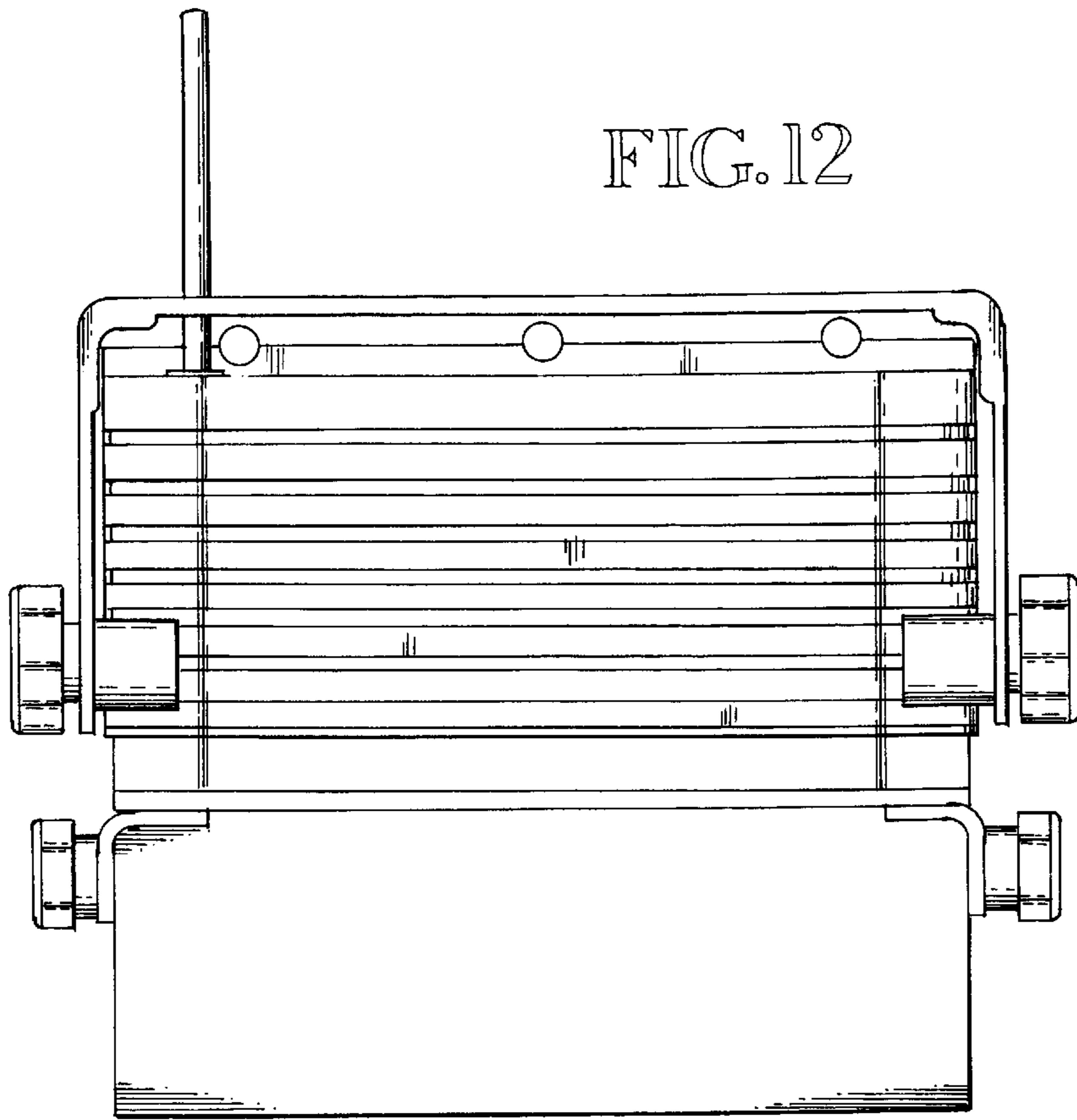
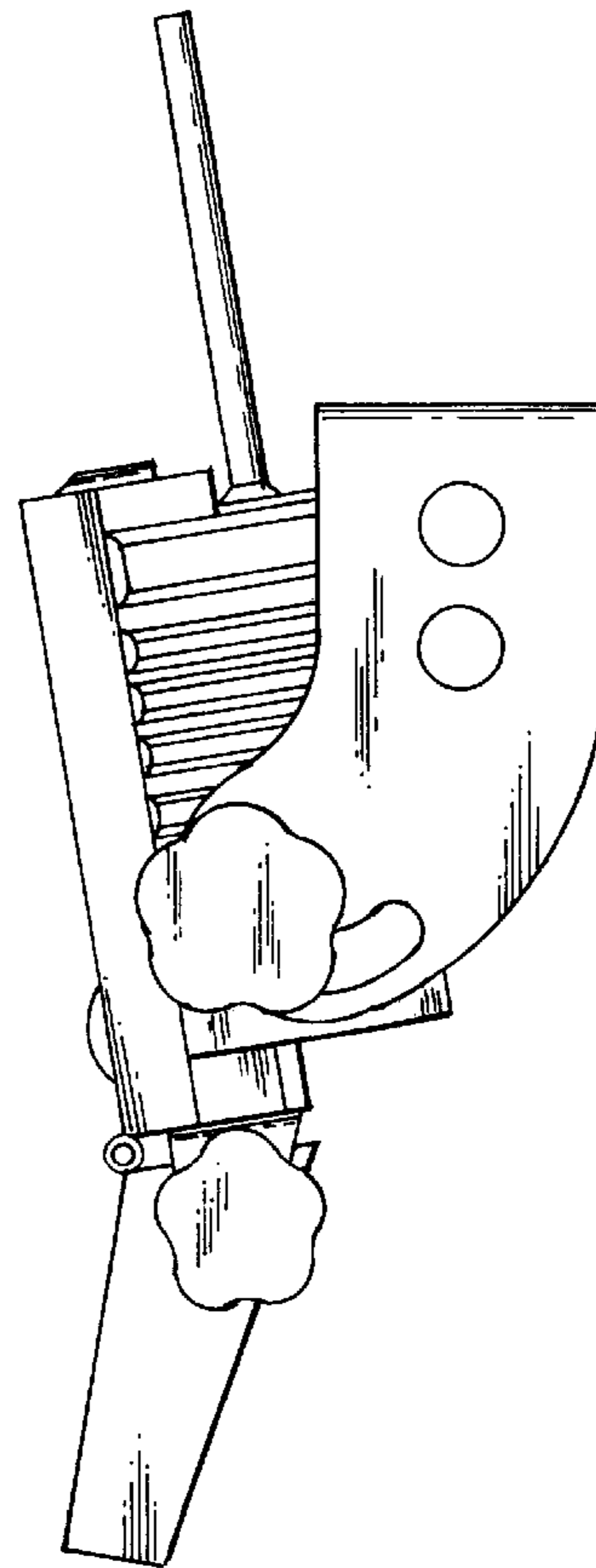

FIG. 13



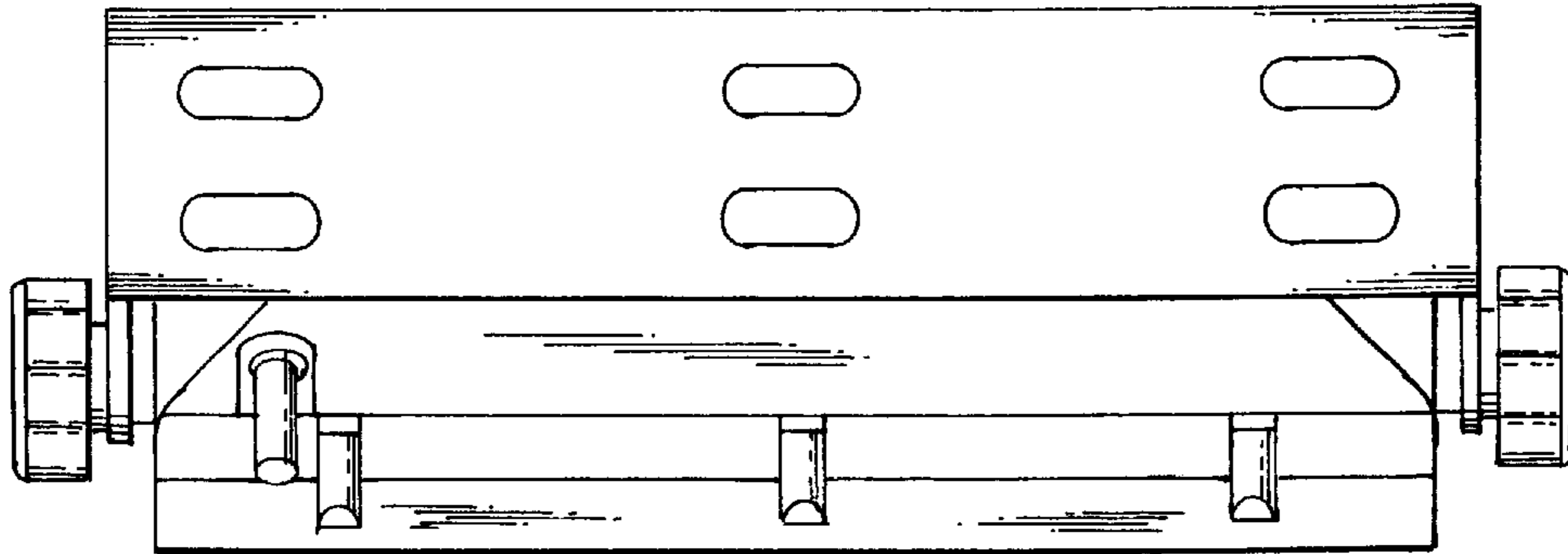

FIG. 14

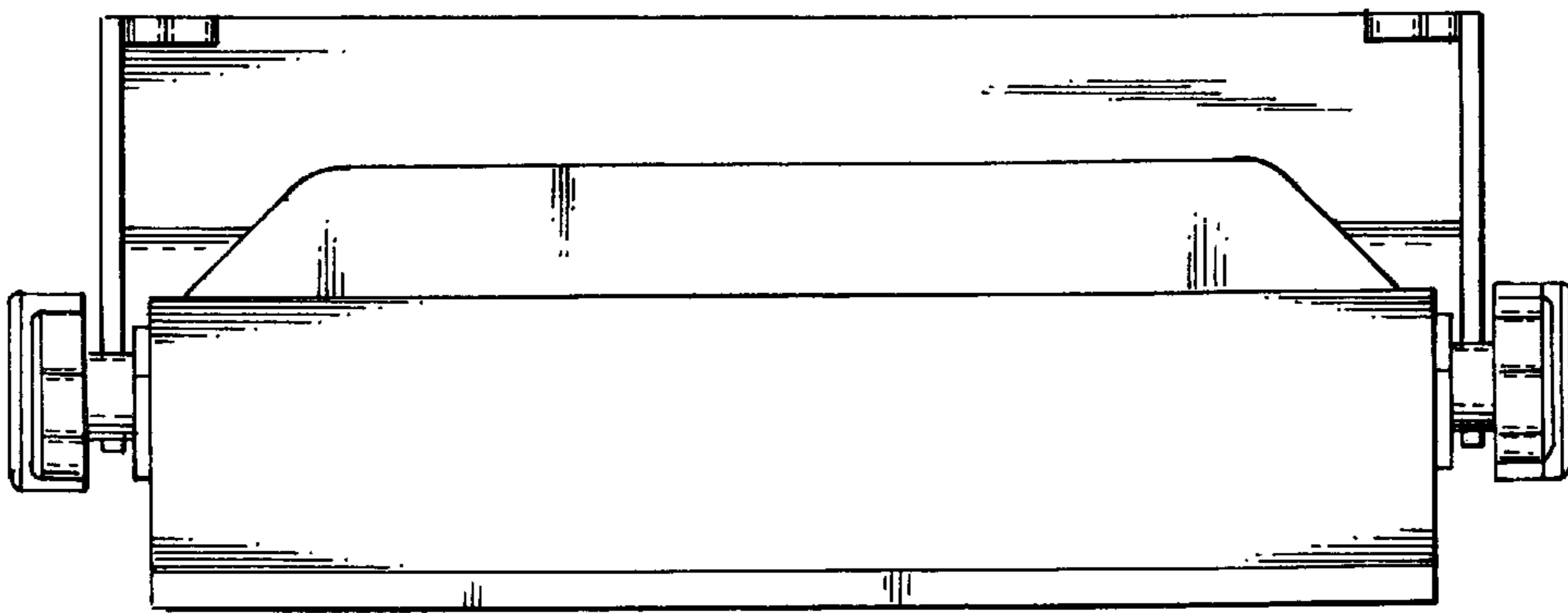

FIG. 15