



US00D407059S

**United States Patent** [19]  
**Henry**

[11] **Patent Number: Des. 407,059**

[45] **Date of Patent: \*\*Mar. 23, 1999**

[54] **WHEEL CHOCK**

[76] Inventor: **Stephen K. Henry**, 3815 Northbrook Dr., C-21, Boulder, Colo. 80302

[\*\*] Term: **14 Years**

[21] Appl. No.: **92,356**

[22] Filed: **Aug. 17, 1998**

**Related U.S. Application Data**

[62] Division of Ser. No. 66,614, Feb. 13, 1997, Pat. No. Des. 402,616.

[51] **LOC (6) Cl.** ..... **12-06**

[52] **U.S. Cl.** ..... **D12/217**

[58] **Field of Search** ..... D12/114, 120, D12/217; 188/4 R, 32; 267/139, 140; 280/293; 410/30, 49

[56] **References Cited**

**U.S. PATENT DOCUMENTS**

2,011,469	8/1935	Brueggemann	.....	188/32
2,992,704	7/1961	Showaker et al.	.....	188/32
3,317,006	5/1967	Patterson	.....	188/32

*Primary Examiner*—Robert M. Spear  
*Attorney, Agent, or Firm*—Dorr, Carson, Sloan & Birney, P.C.

[57] **CLAIM**

The ornamental design for a wheel chock, as shown and described.

**DESCRIPTION**

FIG. 1 is a front perspective view of a wheel chock showing my new design;  
FIG. 2 is a front elevational view of the embodiment shown in FIG. 1, with the rear elevational view being a mirror image of FIG. 8;  
FIG. 3 is a top plan view of the embodiment shown in FIG. 1, taken in the direction of arrow 3—3 in FIG. 2;  
FIG. 4 is a left side elevational view of the embodiment shown in FIG. 1, taken in the direction of arrow 4—4 in FIG. 2;  
FIG. 5 is a right side elevational view of the embodiment shown in FIG. 1, taken in the direction of arrow 5—5 in FIG. 2; and,  
FIG. 6 is a bottom plan view of the embodiment shown in FIG. 1, taken in the direction of arrow 6—6 FIG. 2.

**1 Claim, 2 Drawing Sheets**

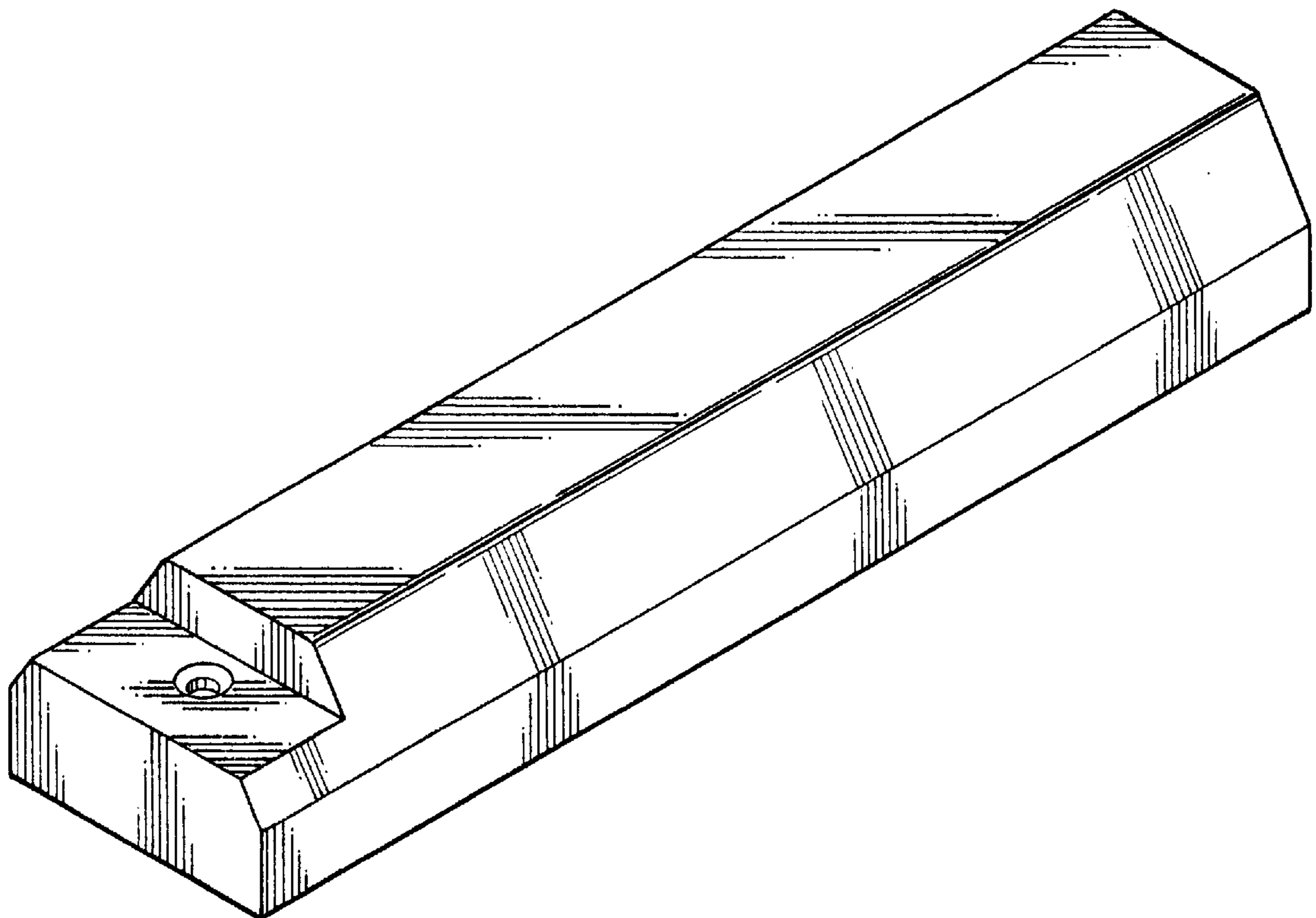

Fig. 1

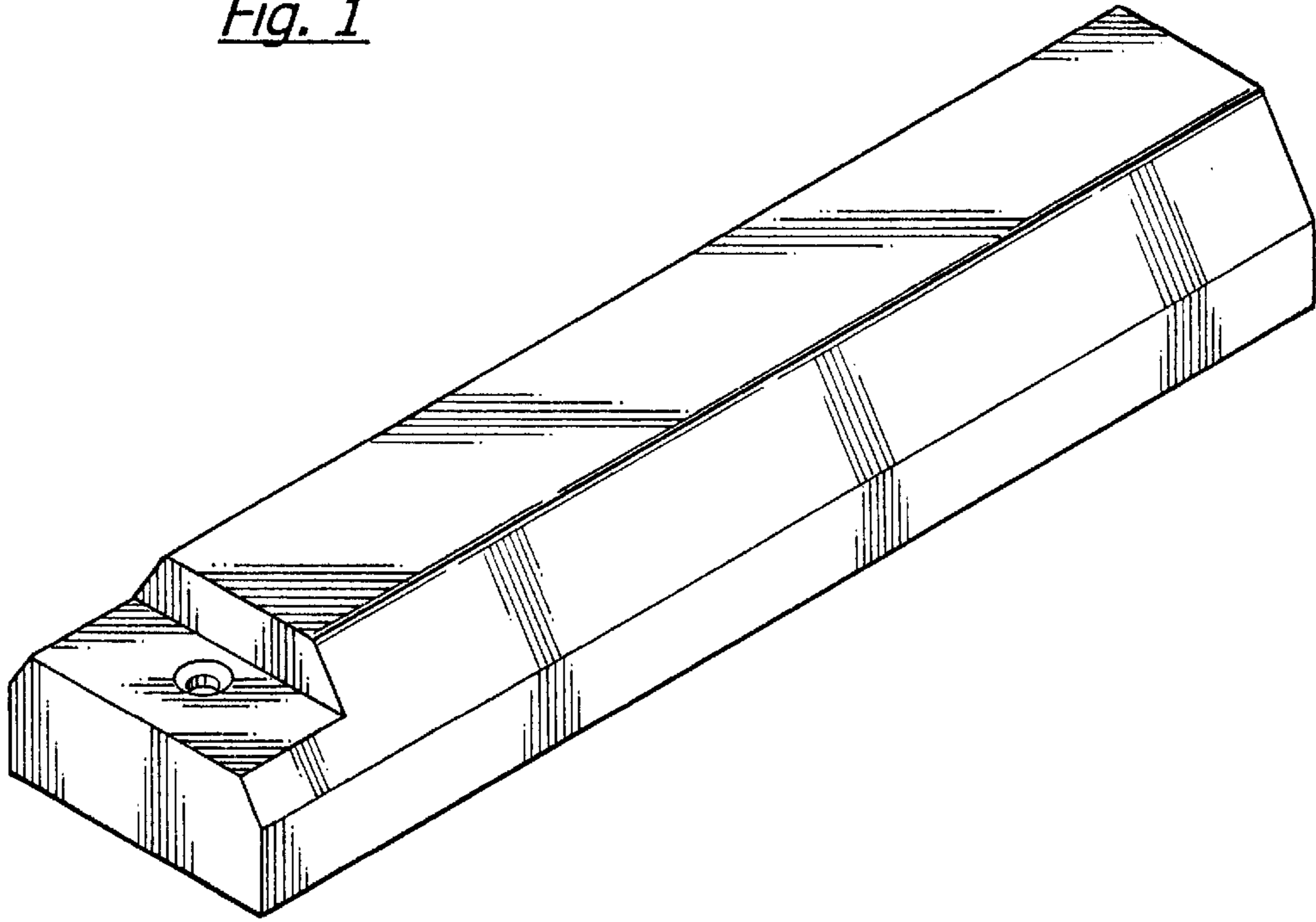

Fig. 2

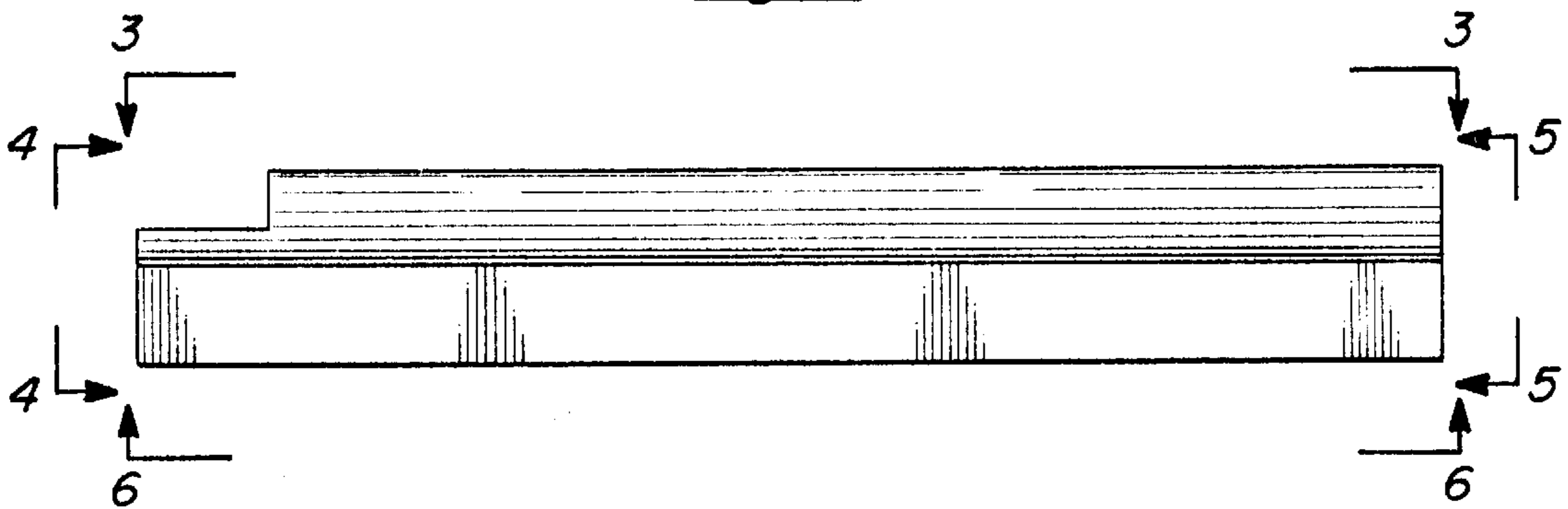

Fig. 3

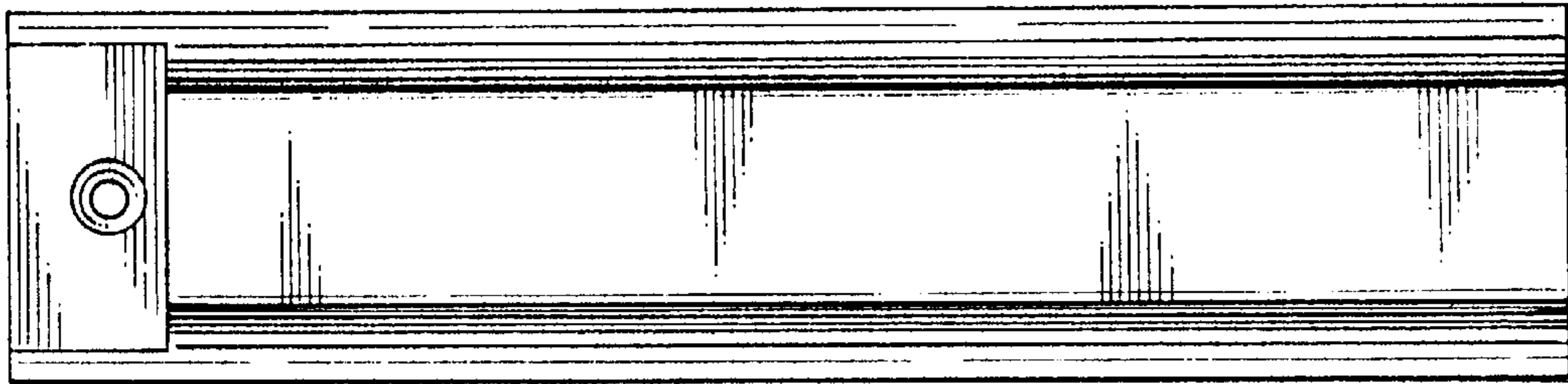

Fig. 4

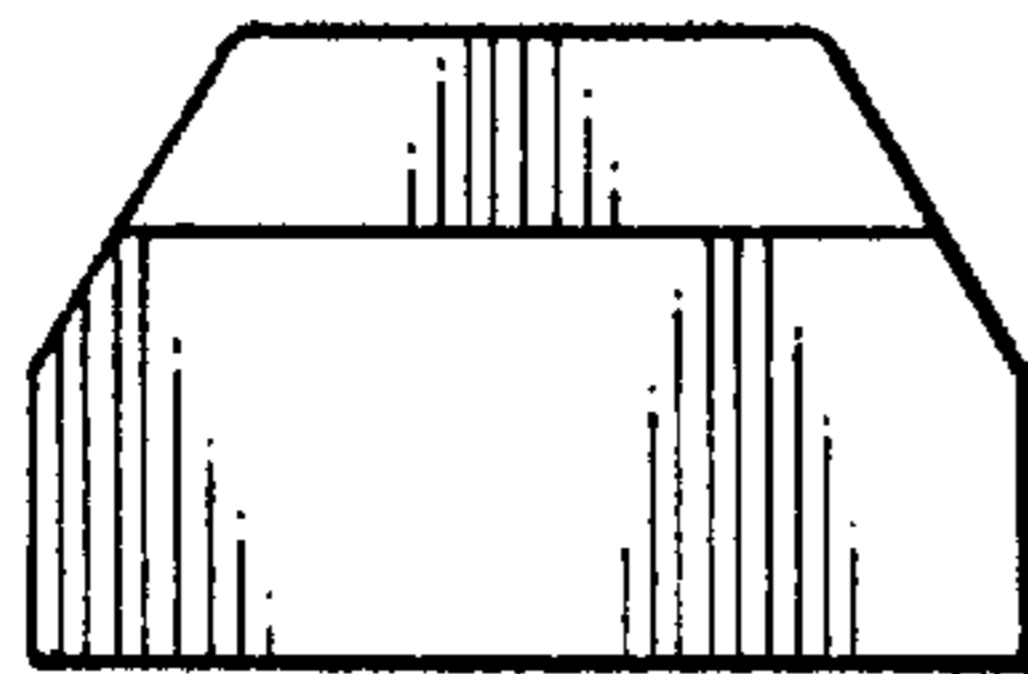

Fig. 5

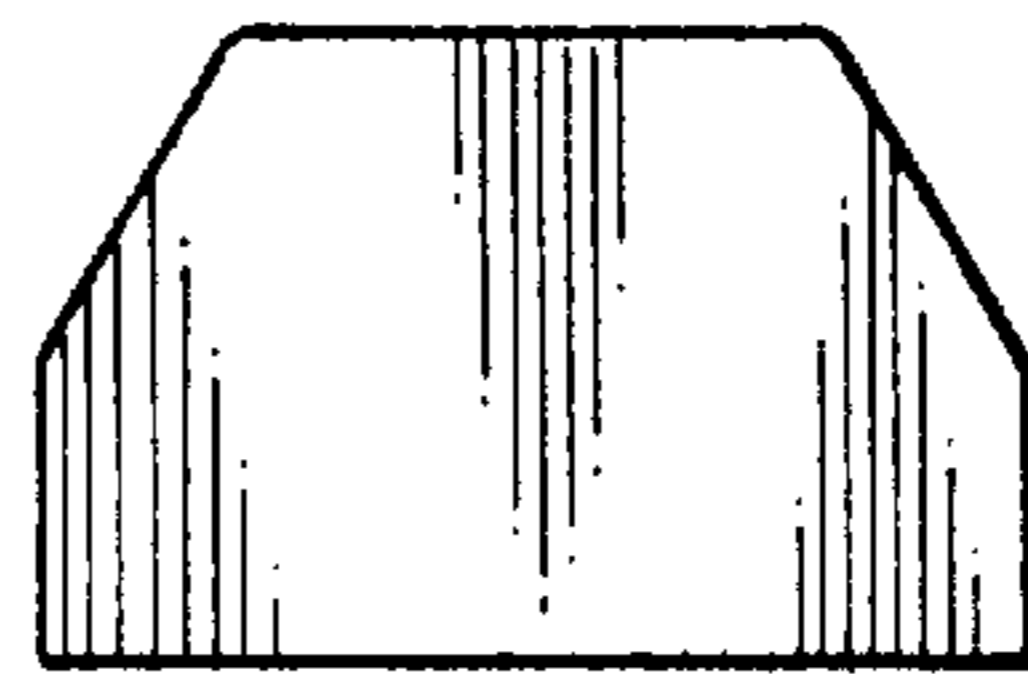

Fig. 6

