



US00D407007S

# United States Patent [19]

Sacco et al.

[11] Patent Number: Des. 407,007

[45] Date of Patent: \*\*Mar. 23, 1999

[54] KEY FOR A MOTOR VEHICLE

D. 390,195 2/1998 Chen ..... D13/168  
D. 393,996 5/1998 Sacco et al. .... D8/347

[75] Inventors: Bruno Sacco, Sindelfingen; Peter Pfeiffer, Boblingen, both of Germany

Primary Examiner—Brian N. Vinson  
Attorney, Agent, or Firm—Evenson, McKeown, Edwards & Lenahan, PLLC

[73] Assignee: Daimler-Benz Aktiengesellschaft, Stuttgart, Germany

[\*\*] Term: 14 Years

### [57] CLAIM

The ornamental design for a key for a motor vehicle, as shown and described.

[21] Appl. No.: 79,497

### DESCRIPTION

[22] Filed: Nov. 17, 1997

### [30] Foreign Application Priority Data

May 17, 1997 [DE] Germany ..... M 97 04 698

FIG. 1 is a perspective view of a key for a motor vehicle according to our novel design;  
FIG. 2 is a top view of the key for a motor vehicle of FIG. 1 according to our novel design;  
FIG. 3 is a bottom view of the key for a motor vehicle of FIG. 1 according to our novel design;  
FIG. 4 is a right side view of the key for a motor vehicle of FIG. 1 according to our novel design;  
FIG. 5 is a left side view of the key for a motor vehicle of FIG. 1 according to our novel design;  
FIG. 6 is a front view of the key for a motor vehicle of FIG. 1 according to our novel design; and,  
FIG. 7 is a rear view of the key for a motor vehicle of FIG. 1 according to our novel design.

[51] LOC (6) Cl. .... 08-07

[52] U.S. Cl. .... D8/347; D13/182

[58] Field of Search ..... D13/162, 168;  
D21/324; D14/174, 191, 218; D8/347; D3/207,  
208; 340/825, 825.22, 825.23, 825.24, 825.25,  
825.31, 825.32, 825.36, 825.58, 825.69,  
825.72; 123/179.2; 341/176

The broken-line disclosure in the views is for illustrative purposes only and forms no part of the claimed design.

### [56] References Cited

#### U.S. PATENT DOCUMENTS

D. 358,543 5/1995 Amber ..... D8/347  
D. 370,339 6/1996 Pinchuk ..... D3/208  
D. 383,895 9/1997 Christie ..... D8/347 X

1 Claim, 3 Drawing Sheets

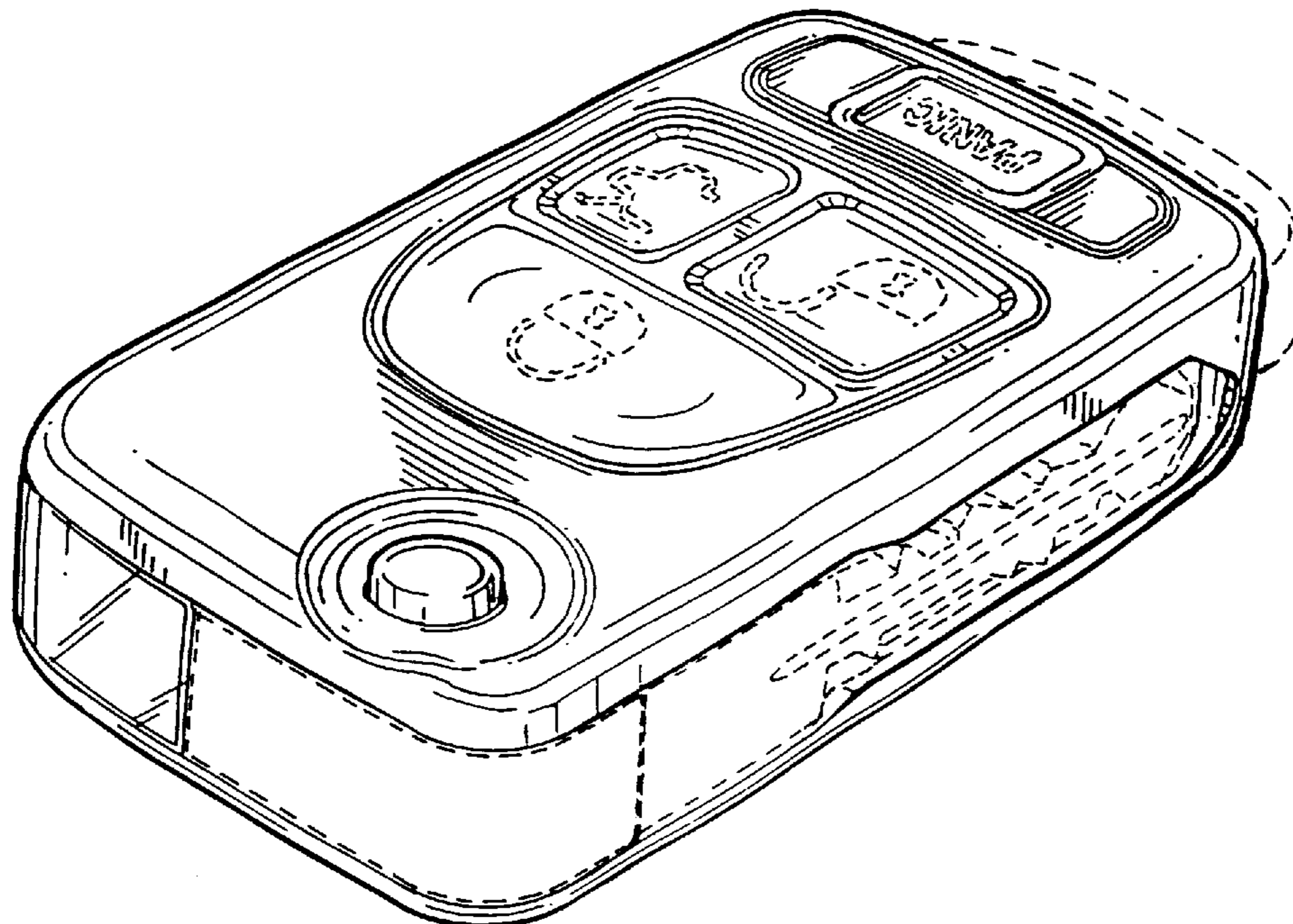

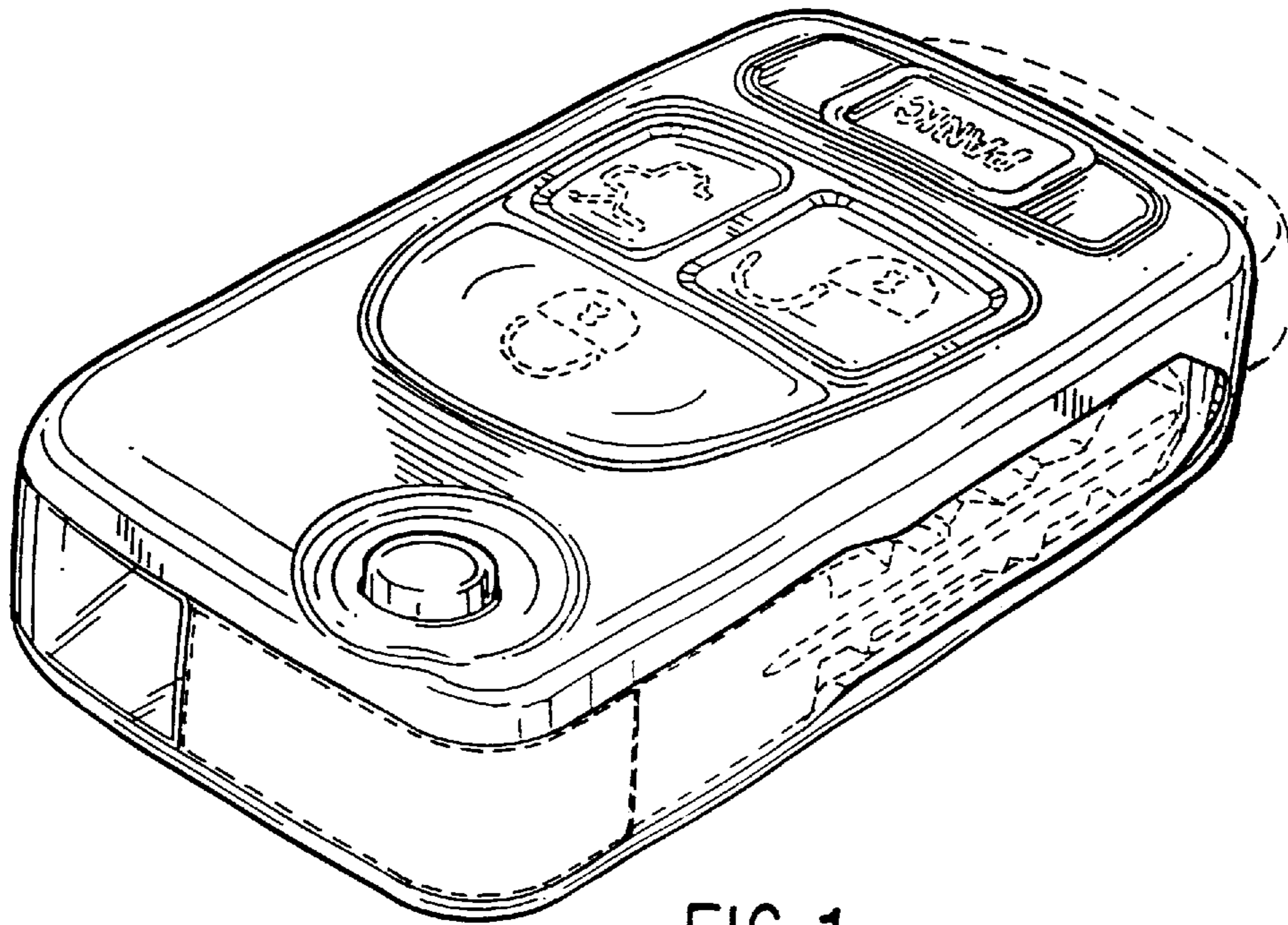

FIG. 1

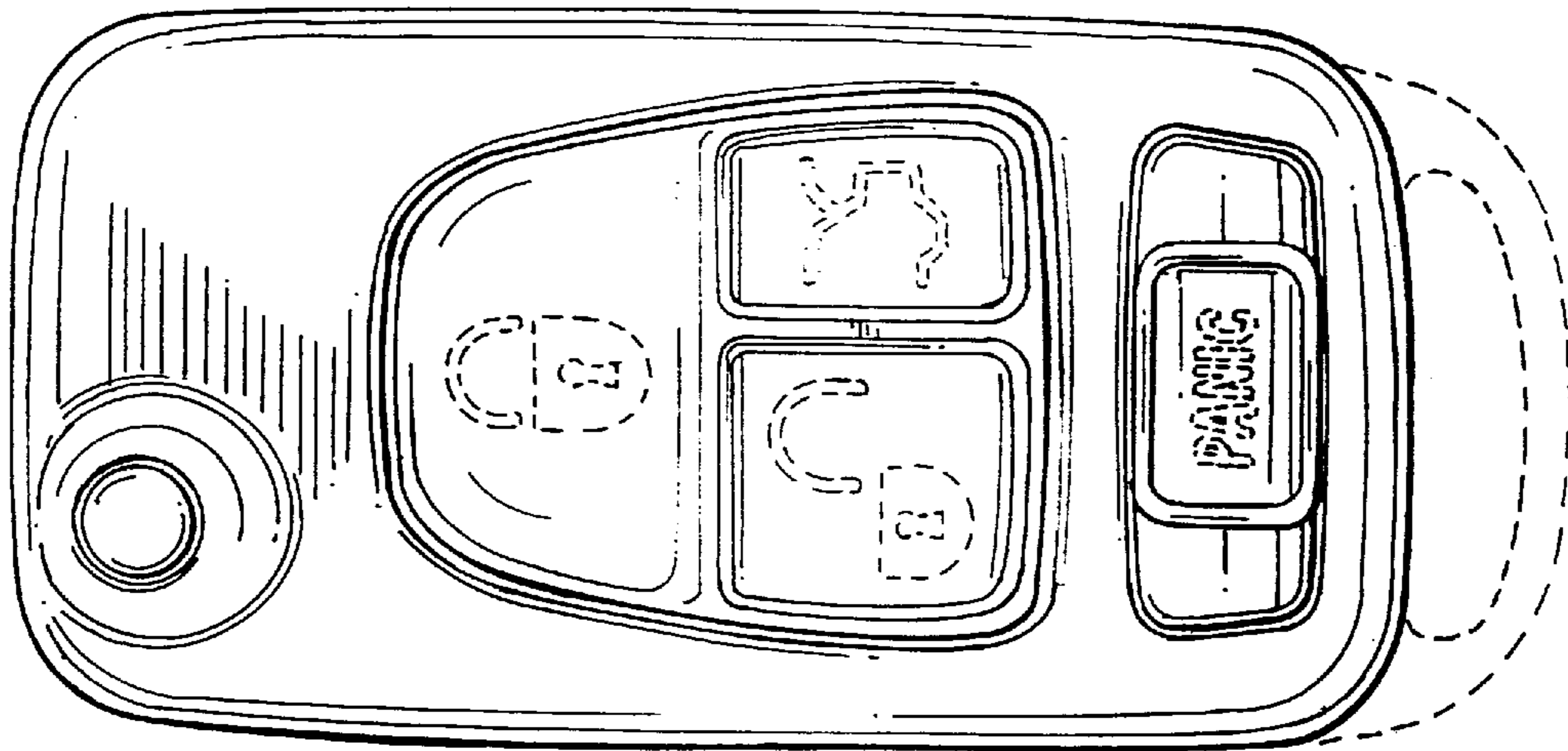

FIG. 2

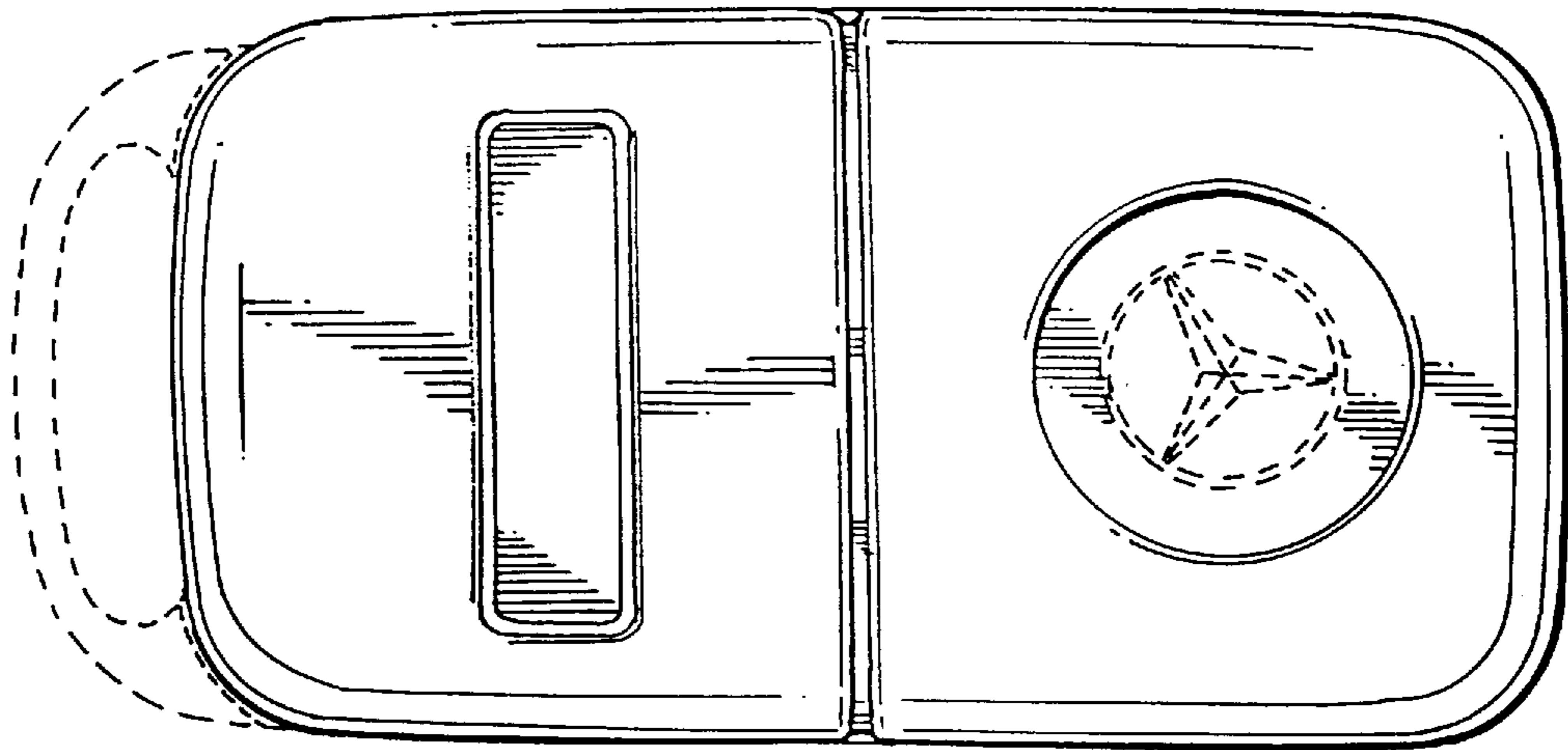

FIG. 3

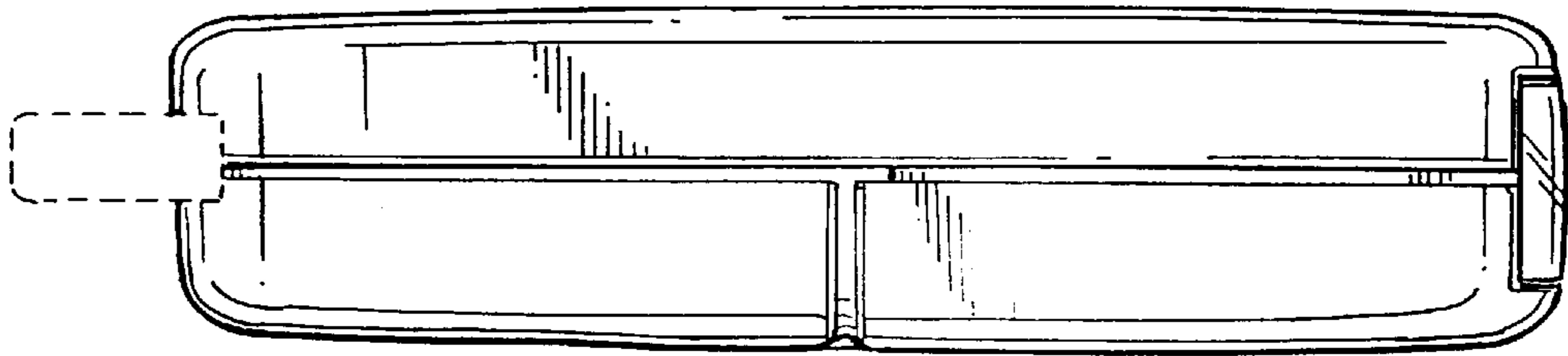

FIG. 4

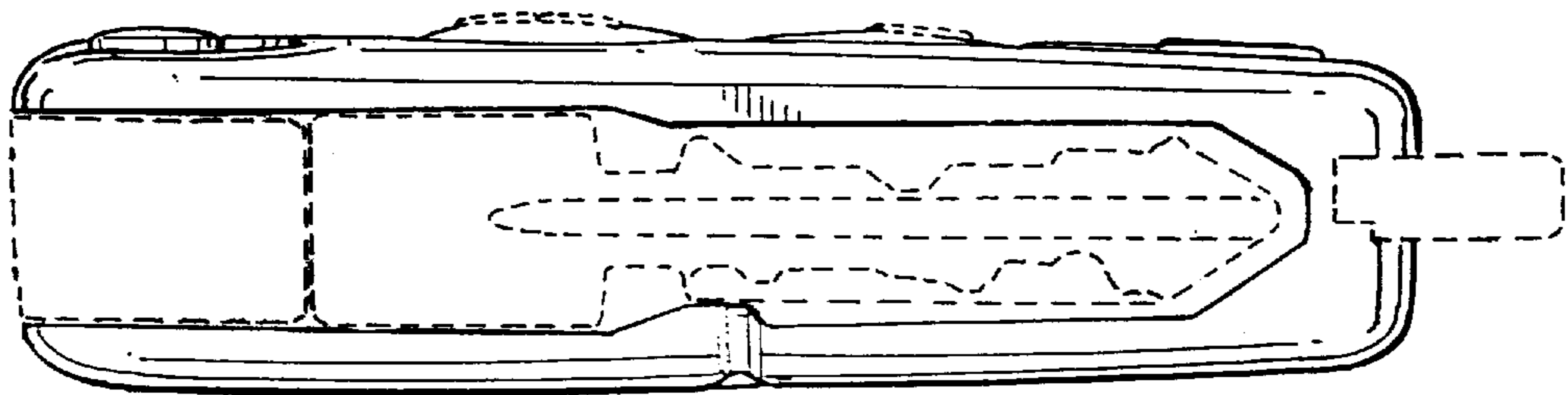

FIG. 5

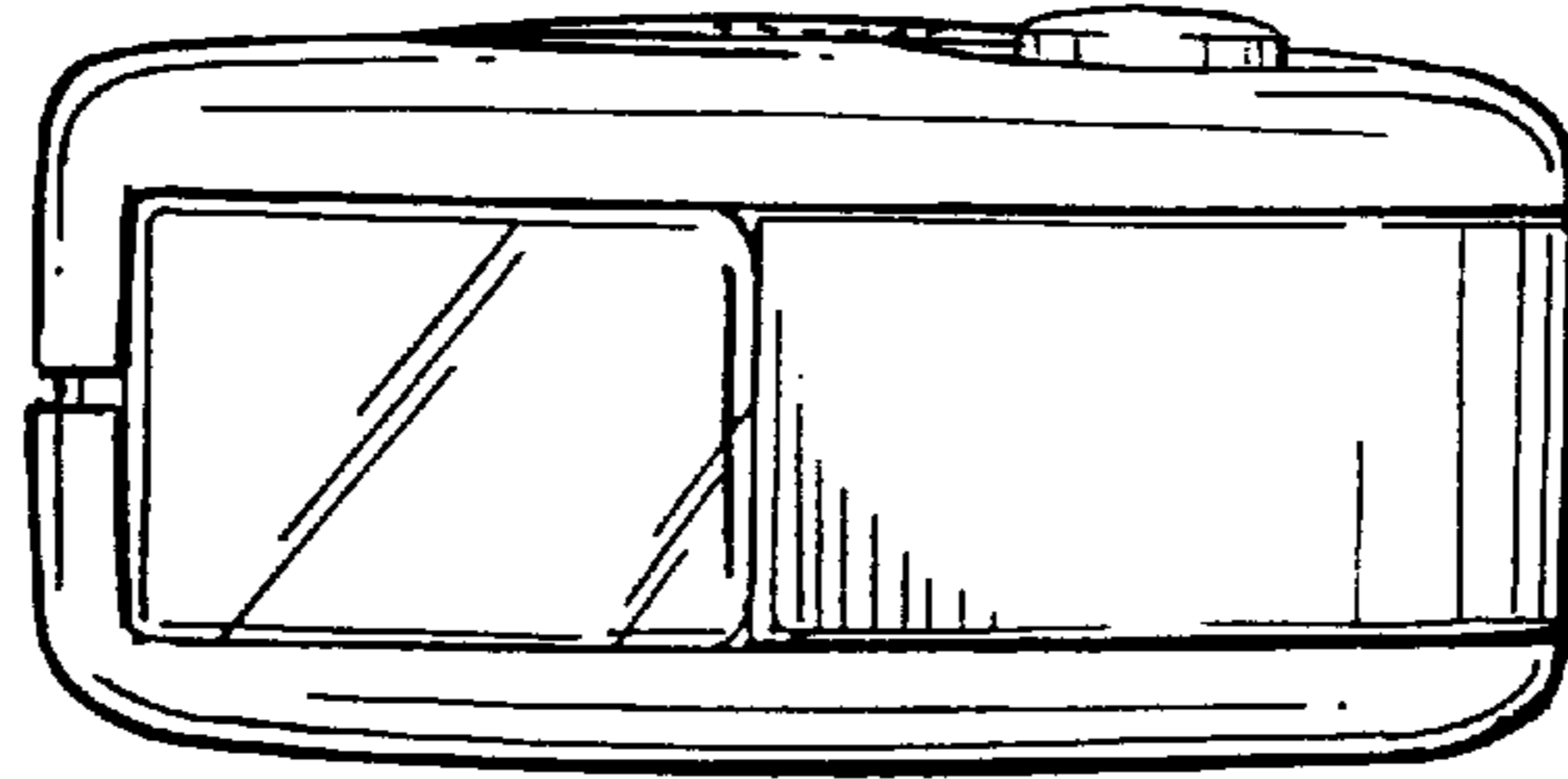

FIG. 6

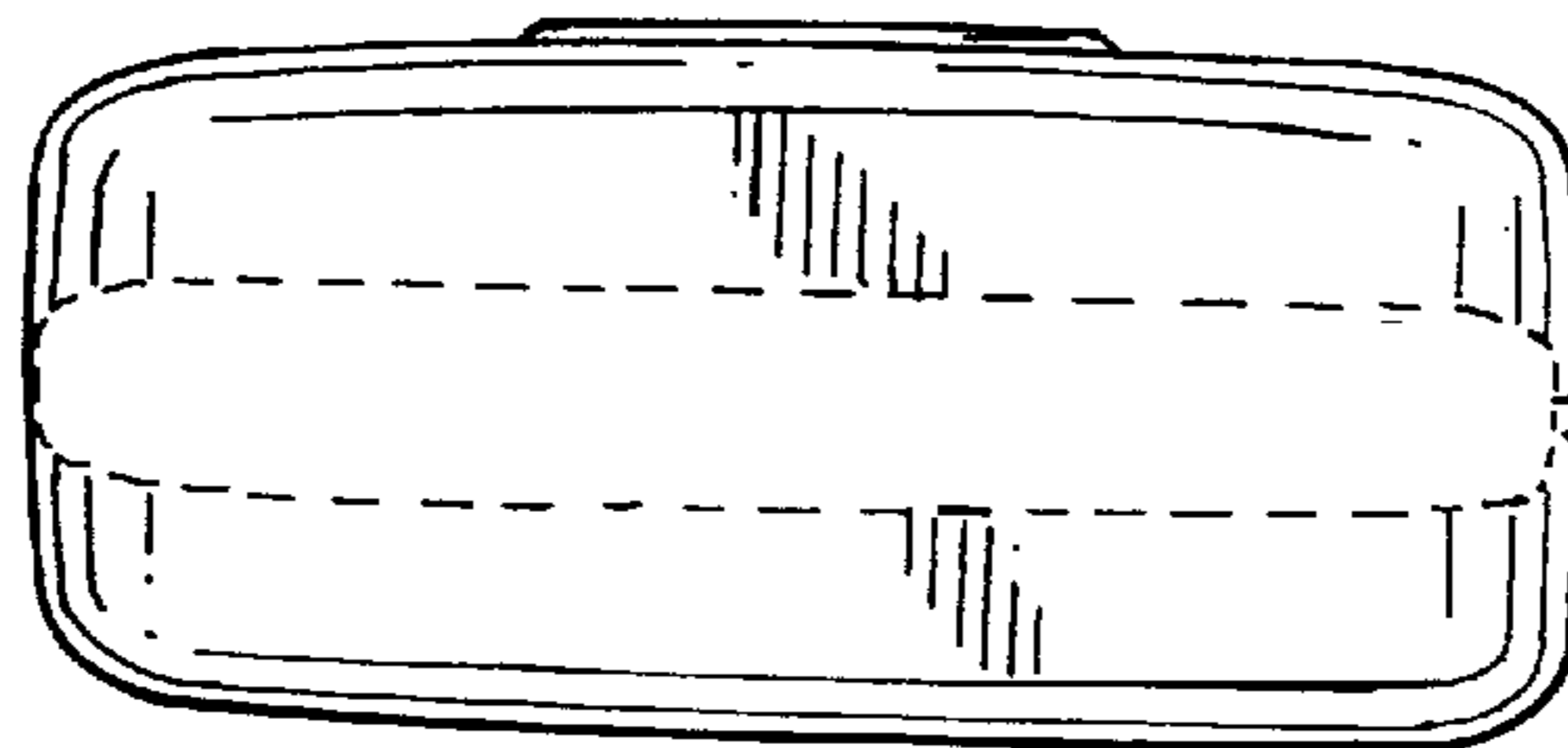

FIG. 7