



US00D406912S

United States Patent [19]

Sacco et al.

[11] Patent Number: **Des. 406,912**

[45] Date of Patent: ****Mar. 16, 1999**

[54] **EXTERIOR SURFACE CONFIGURATION OF A REAR VEHICLE LIGHT**

D. 370,985 6/1996 Sacco et al. D26/28
D. 388,200 12/1997 Tomborde et al. D26/28
D. 396,310 7/1998 Sacco et al. D26/28

[75] Inventors: **Bruno Sacco**; **Harald Leschke**, both of Sindelfingen, Germany; **Olivier Boulay**, Tokyo, Japan; **Shuichi Yamashita**, Yokohama, Japan; **Anthony Lo**, Tokyo, Japan; **Wolfgang Müller**, Sindelfingen, Germany; **Anton Reichel**, Ditzingen, Germany; **Werner Heinz**, Lehnigen, Germany

Primary Examiner—Marcus A. Jackson
Attorney, Agent, or Firm—Evenson, McKeown, Edwards & Lenahan PLLC

[73] Assignee: **Daimler-Benz Aktiengesellschaft**, Stuttgart, Germany

[**] Term: **14 Years**

[57] CLAIM

The ornamental design for an exterior surface configuration of a rear vehicle light, as shown and described.

[21] Appl. No.: **84,791**

DESCRIPTION

[22] Filed: **Mar. 9, 1998**

FIG. 1 is a front view of an exterior surface configuration of a rear vehicle light according to our novel design; FIG. 2 is a top view of an exterior surface configuration of a rear vehicle light according to our novel design; FIG. 3 is a right side view of an exterior surface configuration of a rear vehicle light according to our novel design; FIG. 4 is a perspective view from the front right of an exterior surface configuration of a rear vehicle light according to our novel design;

[30] Foreign Application Priority Data

Sep. 8, 1997 [DE] Germany M 97 08 391.7

This design represents one embodiment of a design for exterior surface configuration of a rear vehicle light. The drawings and descriptions represent the right side embodiment. The design also contemplates a mirror symmetrical embodiment on the left side of the vehicle. The dash line included denotes environment and is not part of the claimed design.

[51] **LOC (6) Cl.** **26-06**

[52] **U.S. Cl.** **D26/28**

[58] **Field of Search** D26/28-36; 362/61, 362/80, 81, 83.4, 330, 336, 337, 267

[56] References Cited

U.S. PATENT DOCUMENTS

D. 364,239 11/1995 Sacco et al. D26/28

1 Claim, 2 Drawing Sheets

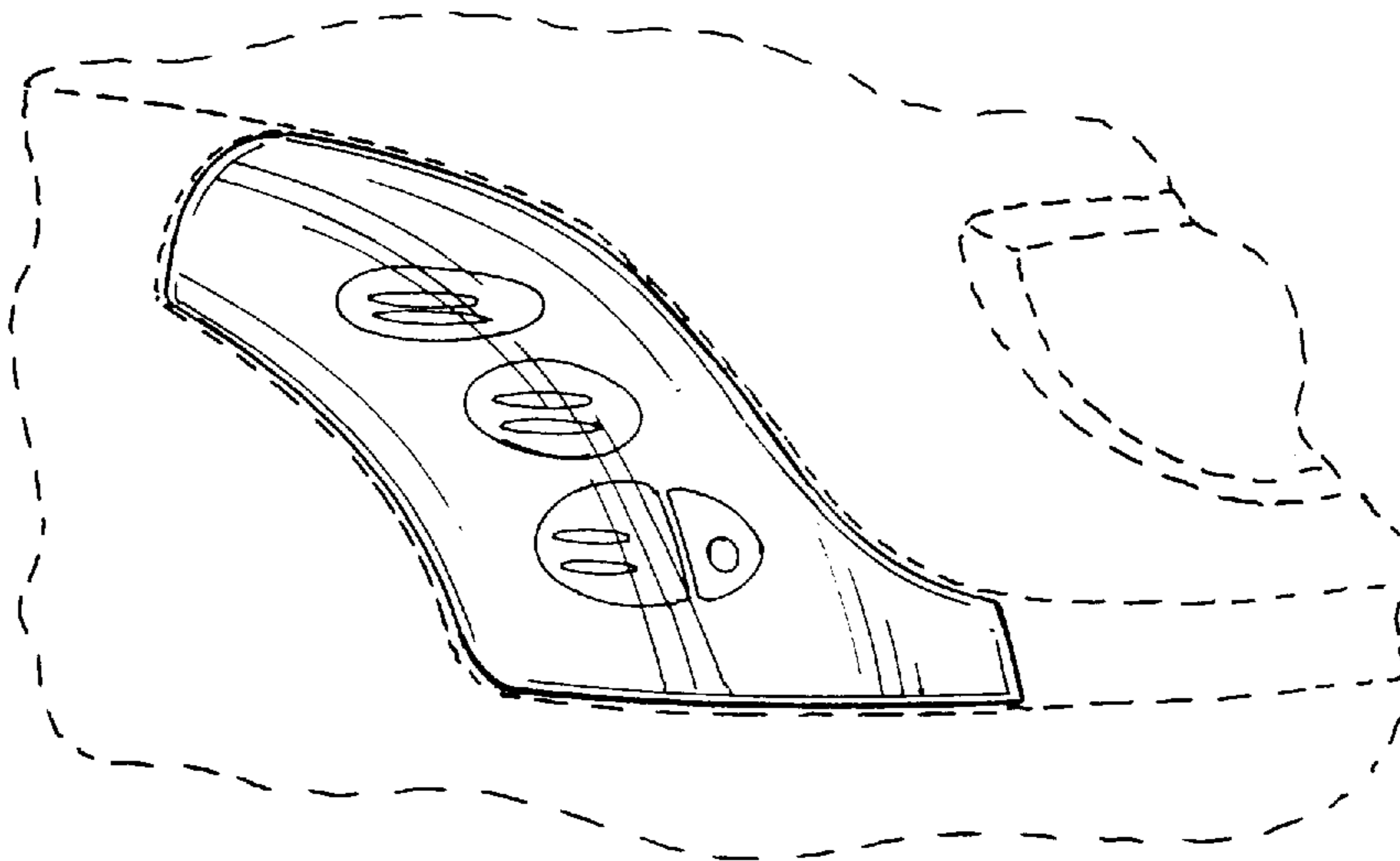

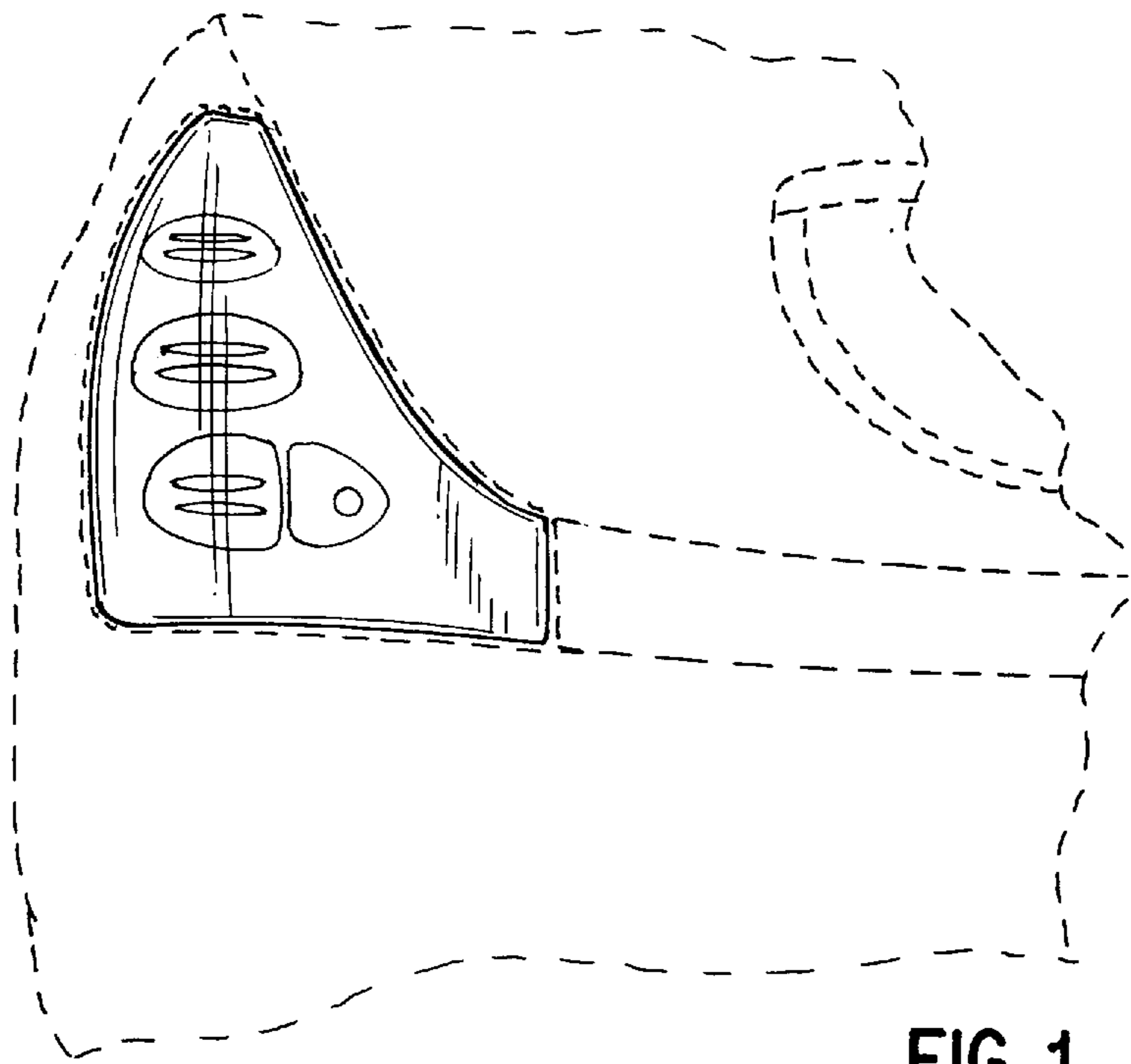

FIG. 1

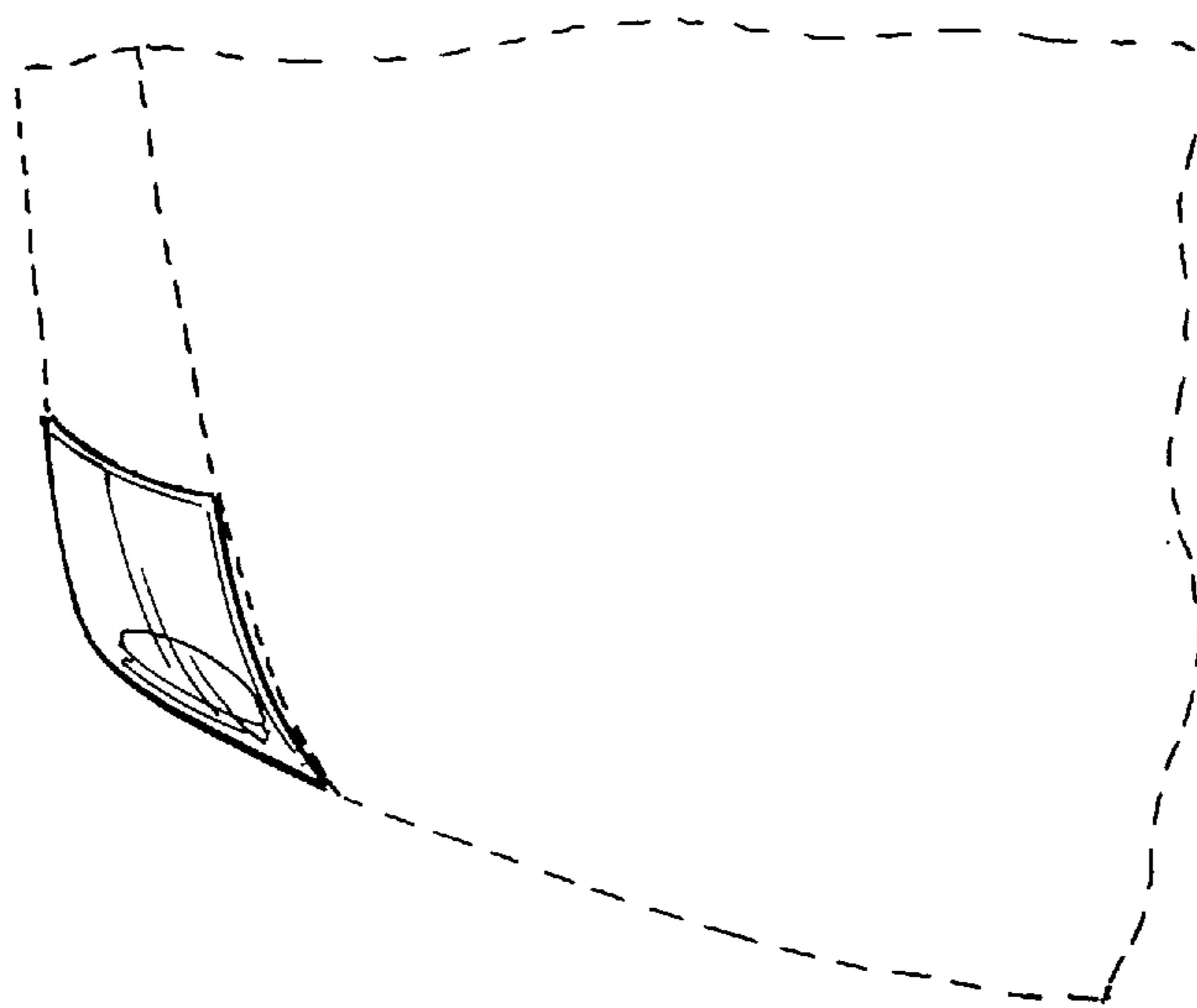

FIG. 2

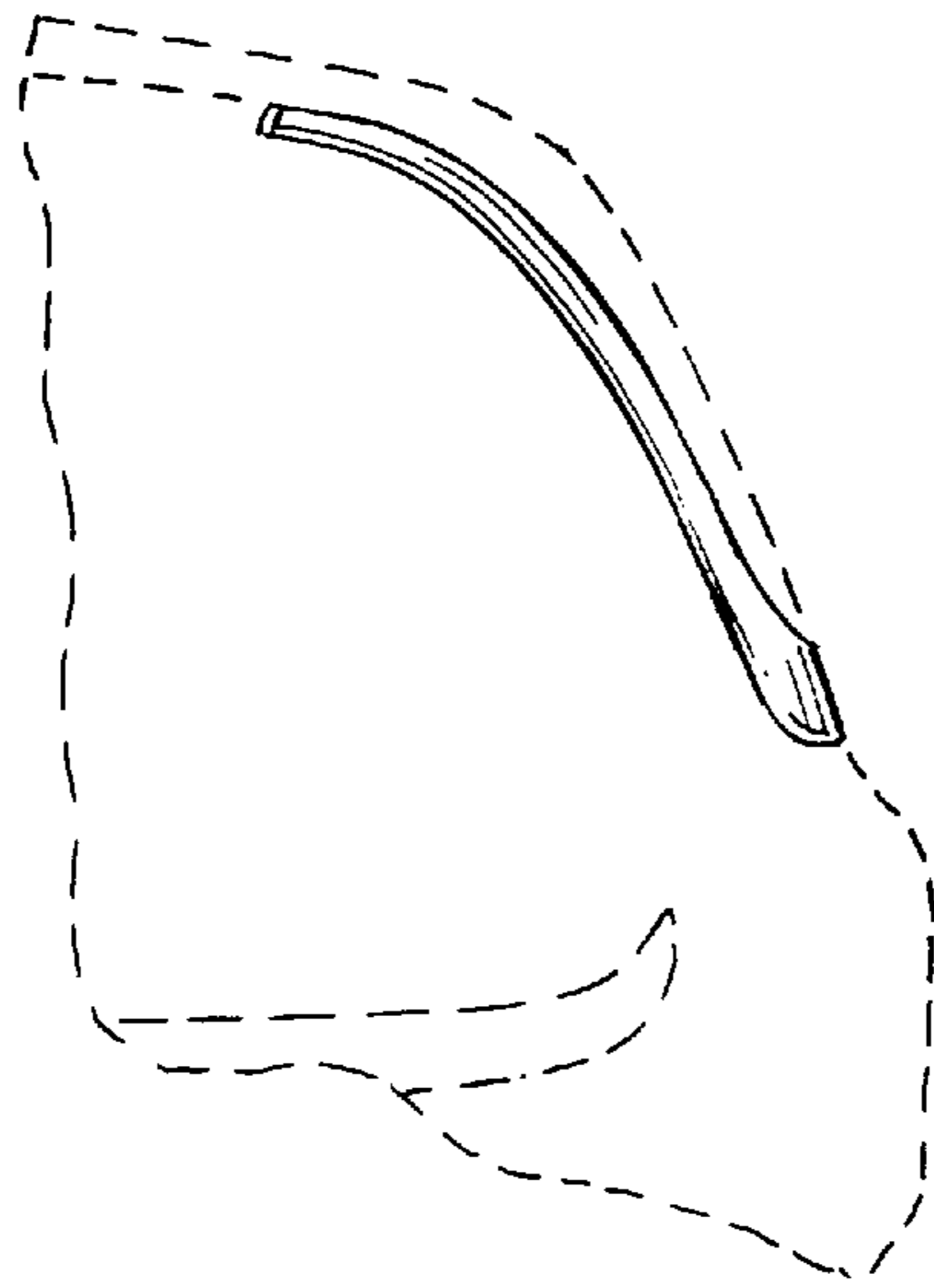

FIG. 3

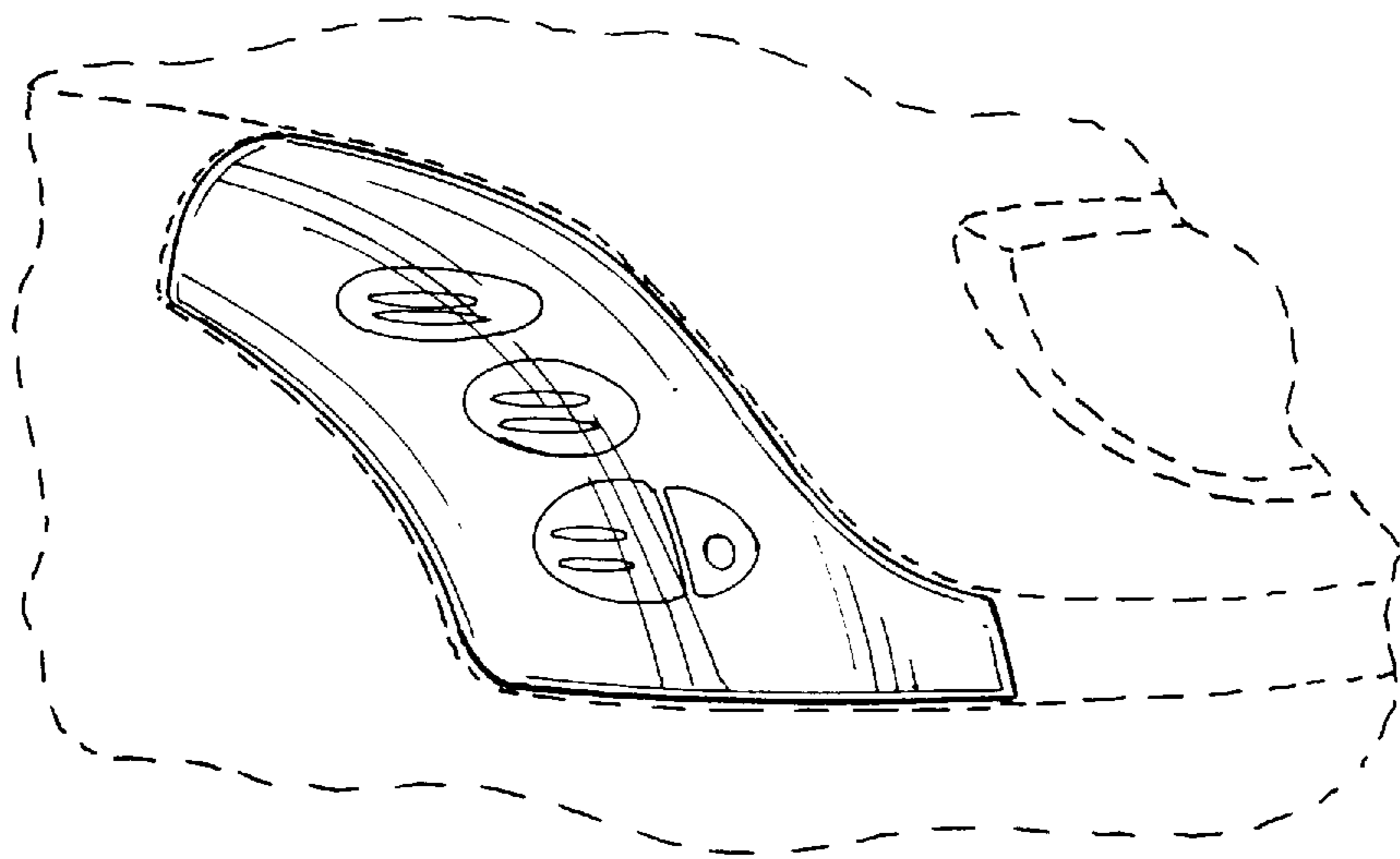

FIG. 4