



US00D406794S

United States Patent [19]

Minowa et al.

[11] Patent Number: **Des. 406,794**

[45] Date of Patent: ****Mar. 16, 1999**

[54] **AUTOMOBILE**

[75] Inventors: **Motoaki Minowa; Hiroyuki Kawase,**
both of Wako, Japan

[73] Assignee: **Honda Giken Kogyo Kabushiki**
Kaisha, Tokyo, Japan

[**] Term: **14 Years**

[21] Appl. No.: **84,718**

[22] Filed: **Mar. 9, 1998**

[30] **Foreign Application Priority Data**

Sep. 12, 1997 [JP] Japan 9-67602

[51] **LOC (6) Cl.** **12-08**

[52] **U.S. Cl.** **D12/91**

[58] **Field of Search** D12/90-92, 86;
296/185

[56] **References Cited**

U.S. PATENT DOCUMENTS

D. 39,898 3/1909 Yoshikawa et al. D12/91

D. 379,945	6/1997	Kawase et al.	D12/91
D. 383,091	9/1997	Sacco et al.	D12/91
D. 391,899	3/1998	Chibukad et al.	D12/91
D. 392,920	3/1998	Venduyn	D12/91
D. 396,203	7/1998	Vematsu et al.	D12/91
D. 397,065	8/1998	Vematsu et al.	D12/91

Primary Examiner—Melody N. Brown
Attorney, Agent, or Firm—Nikaido, Marmelstein, Murray & Oram LLP

[57] **CLAIM**

The ornamental design for an automobile, as shown and described.

DESCRIPTION

FIG. 1 is a left-front perspective view of an automobile showing our new design;
FIG. 2 is a left-rear perspective view thereof;
FIG. 3 is a front view thereof;
FIG. 4 is a rear view thereof;
FIG. 5 is a left side view thereof;
FIG. 6 is a right side view thereof; and,
FIG. 7 is a top plan view thereof.

1 Claim, 6 Drawing Sheets

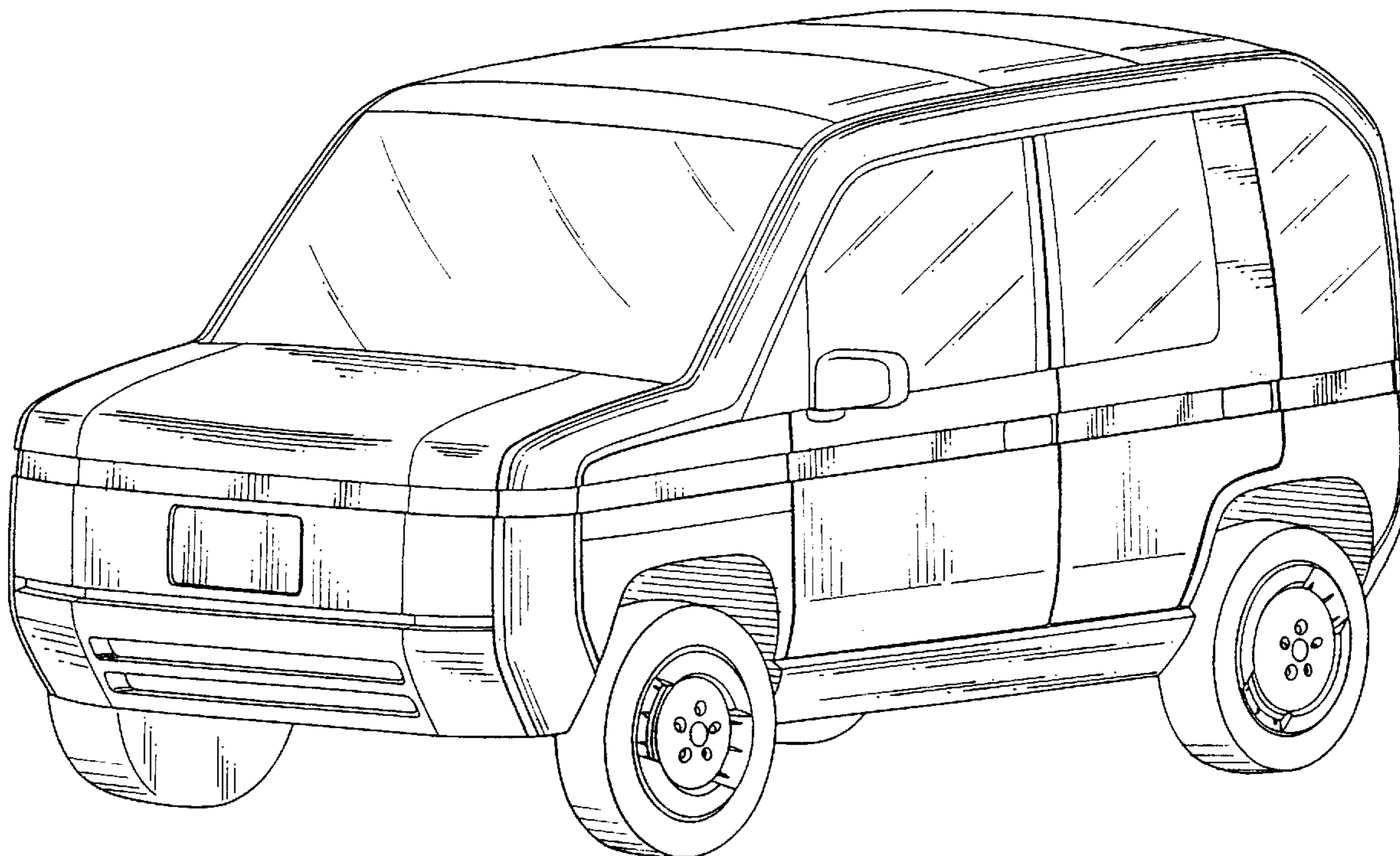

FIG. 1

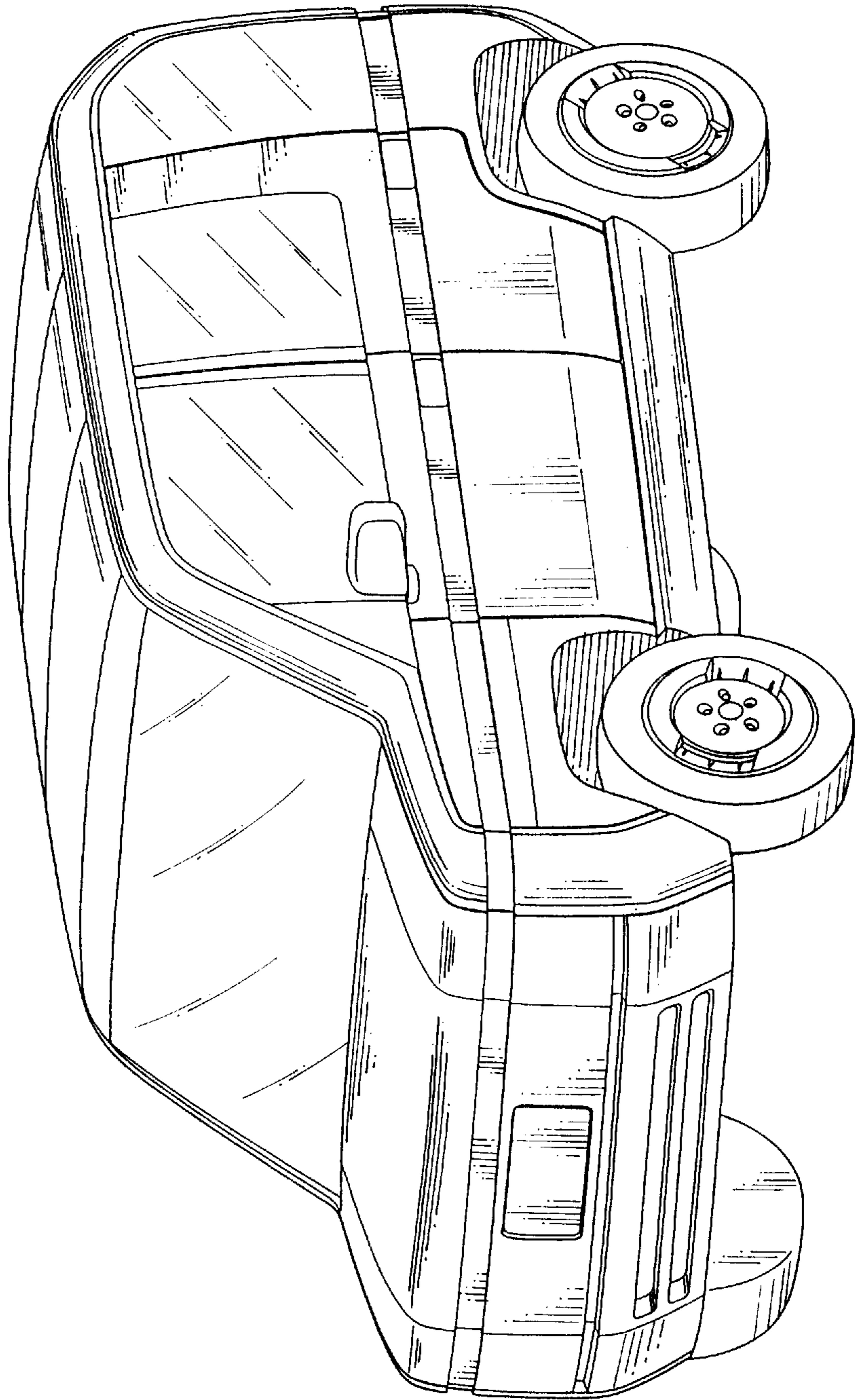

FIG. 2

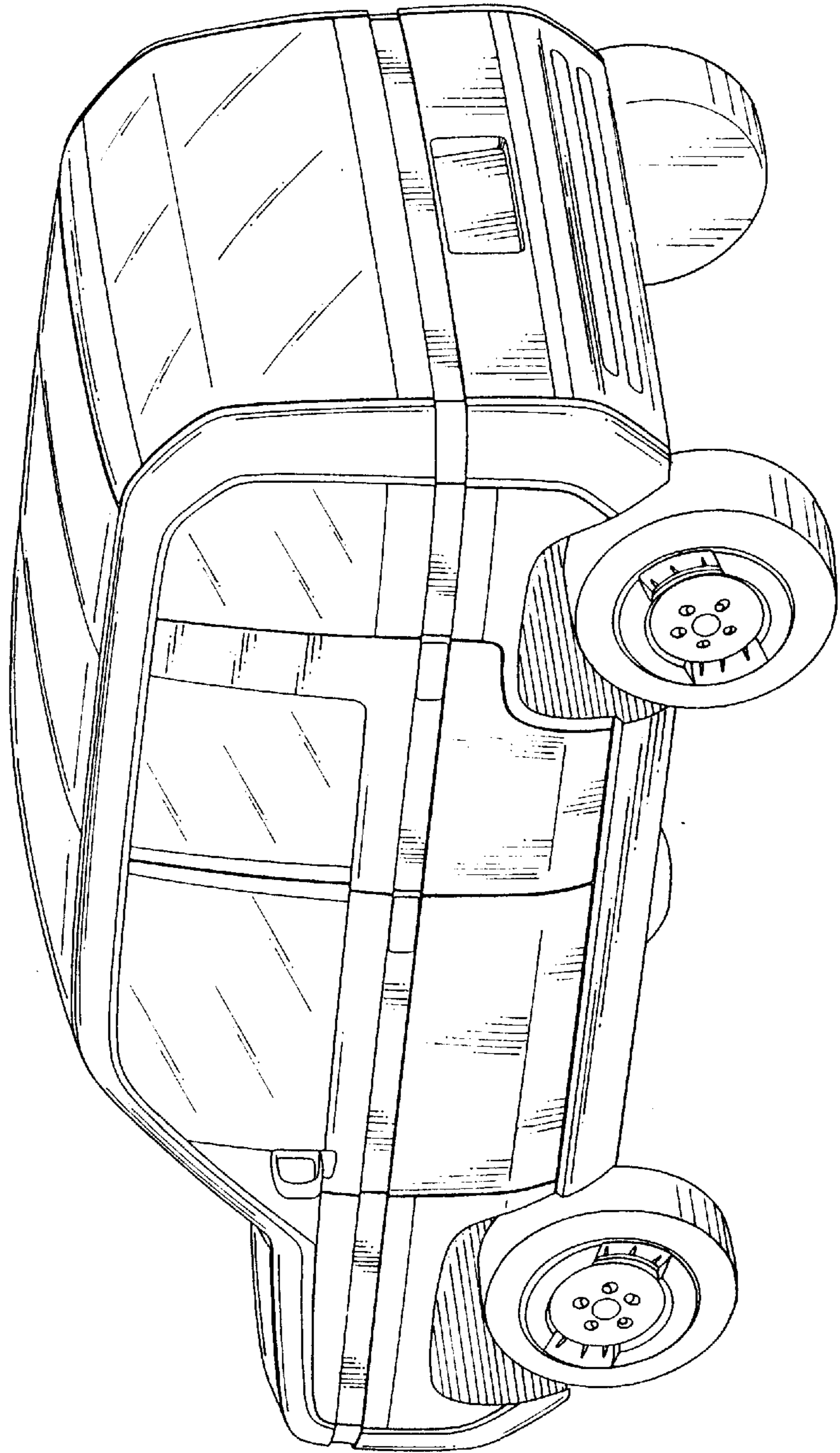

FIG. 4

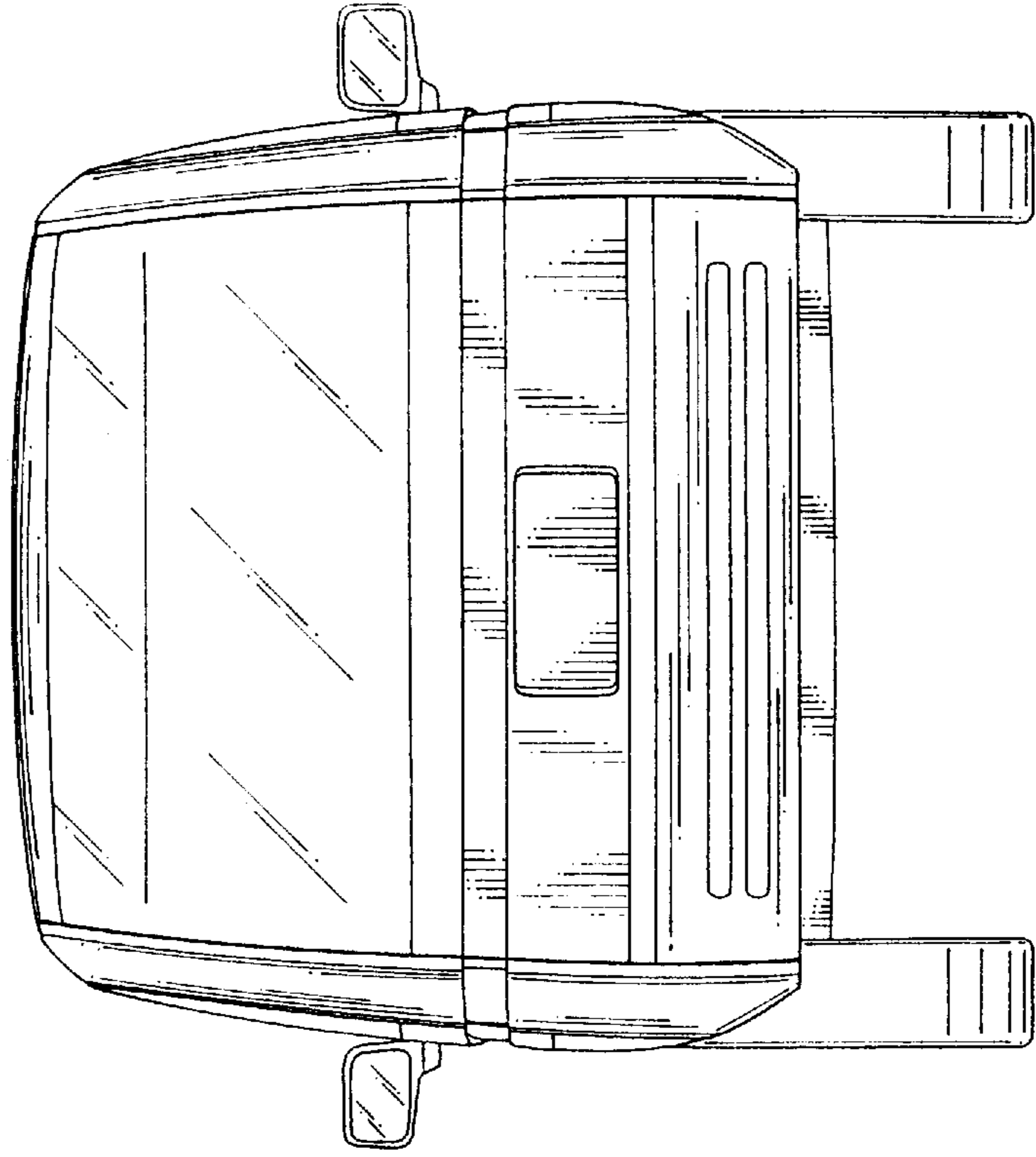

FIG. 3

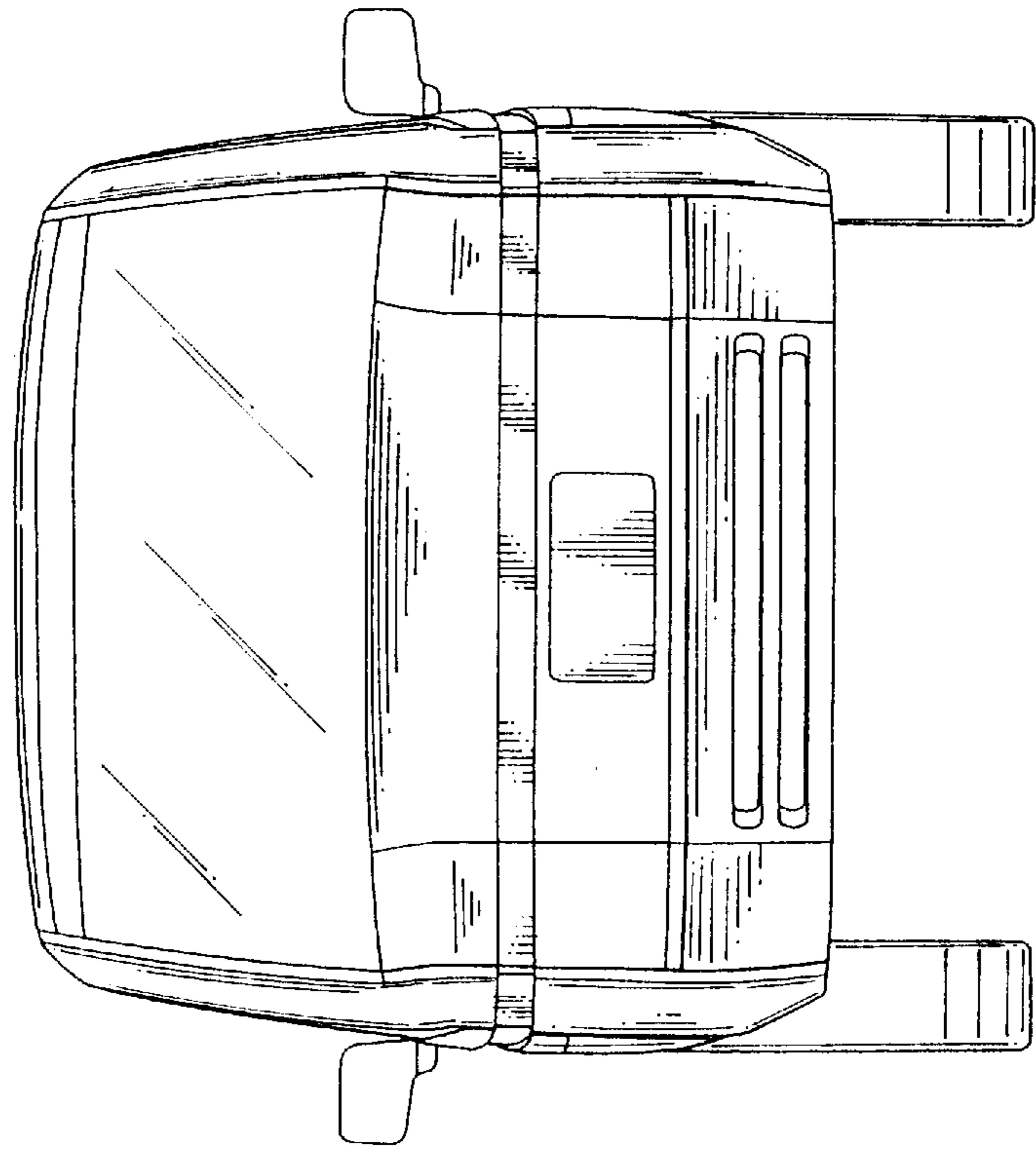

FIG. 5

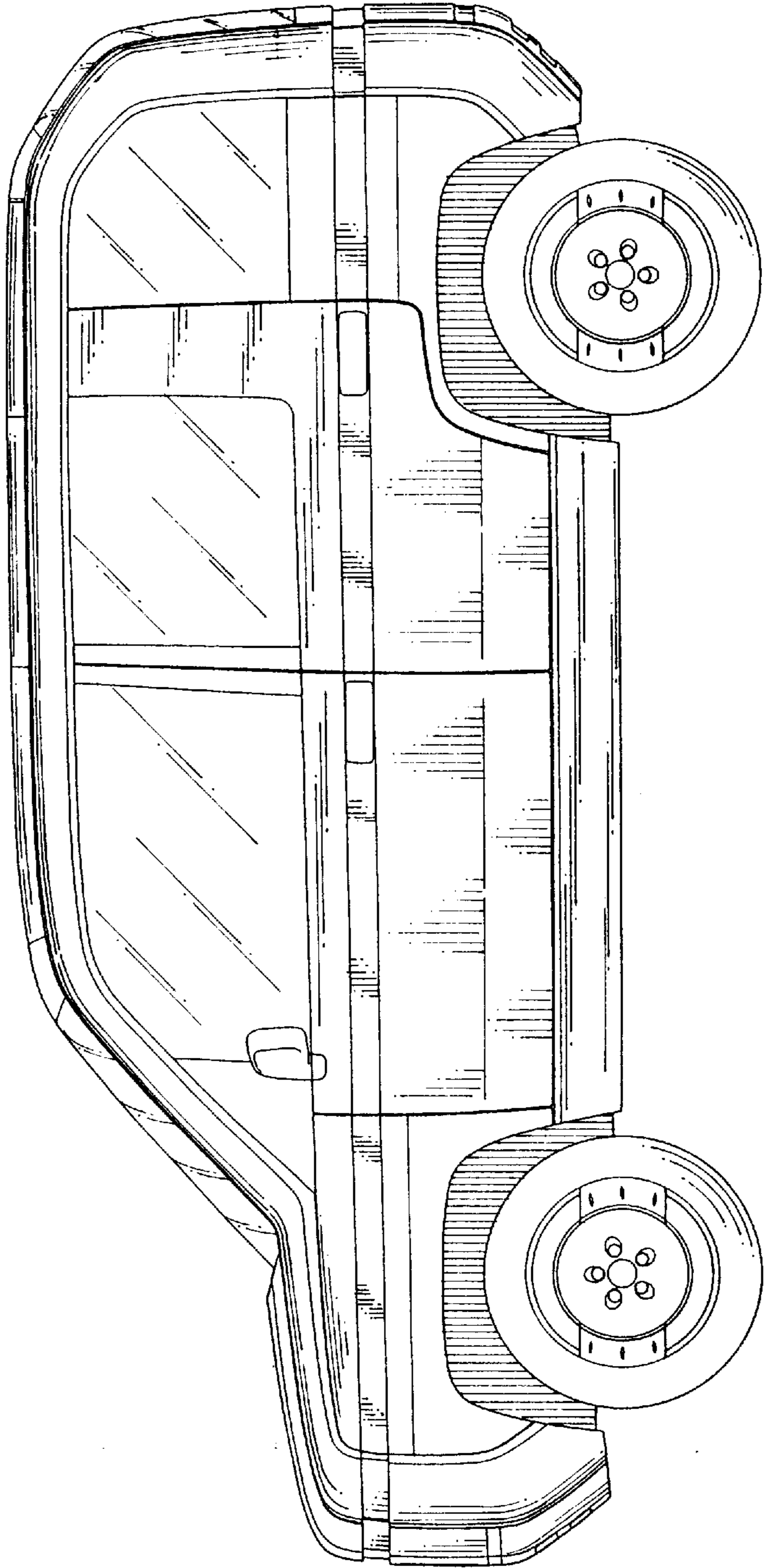

FIG. 6

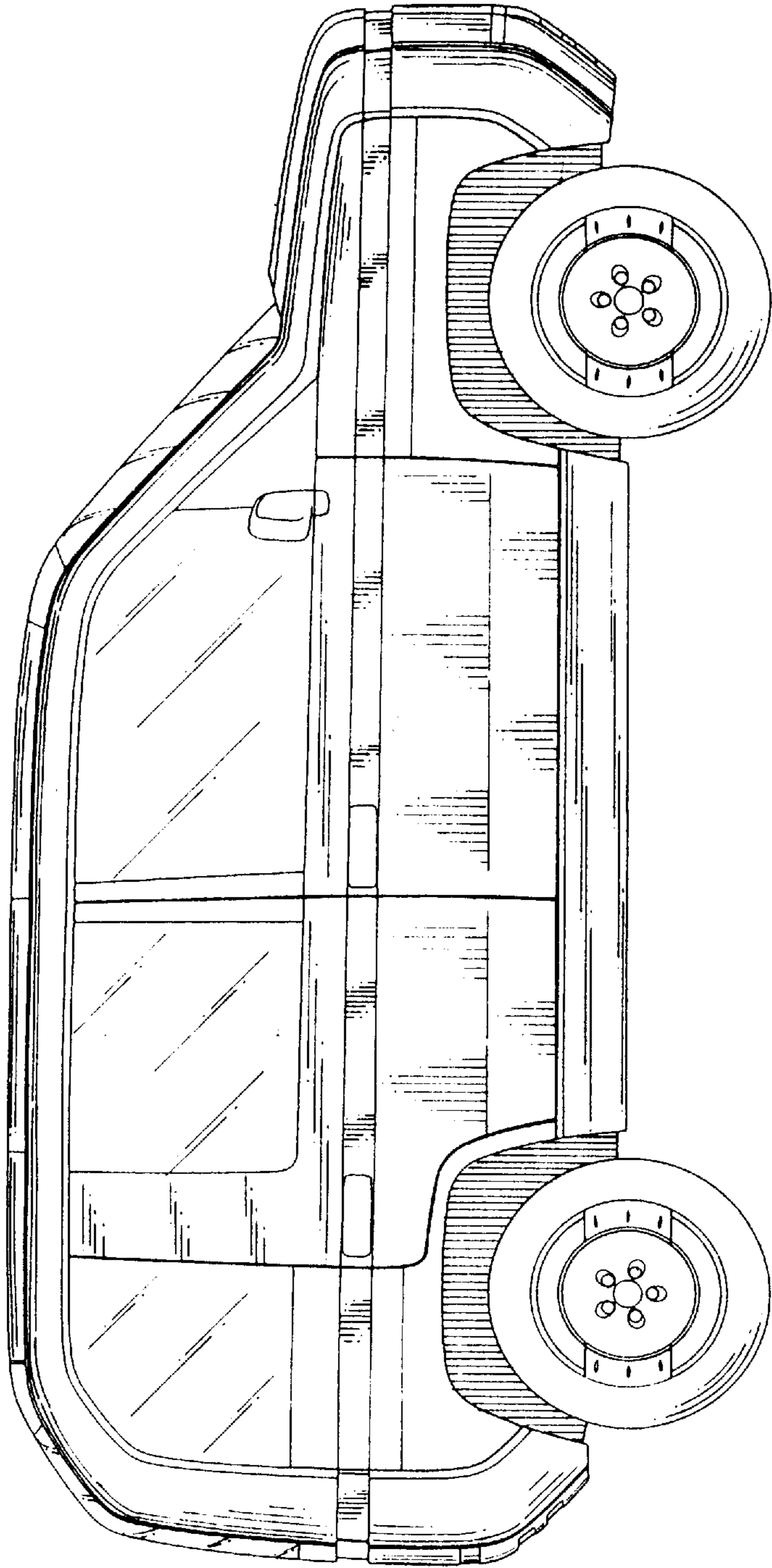

FIG. 7

