



US00D406594S

United States Patent [19]

Miller et al.

[11] Patent Number: **Des. 406,594**

[45] Date of Patent: ****Mar. 9, 1999**

[54] ENGINE ENCLOSURE

[75] Inventors: **Gordon Edward Miller**, Lenoir City, Tenn.; **Larry A. Sliker**, Hewitt, N.J.; **Donald Rodney Flatau**, Oak Ridge; **Andrew Edward Modzik, Jr.**, Knoxville, both of Tenn.; **Richard Lee Forest**, Colona, Ill.

[73] Assignee: **Deere & Company**, Moline, Ill.

[**] Term: **14 Years**

[21] Appl. No.: **81,006**

[22] Filed: **Oct. 17, 1997**

[51] **LOC (6) Cl.** **15-04**

[52] **U.S. Cl.** **D15/31**

[58] **Field of Search** D15/10, 22-26,
D15/28, 31; 180/89.1, 89.12, 900; 414/680,
685, 686

[56] References Cited

U.S. PATENT DOCUMENTS

D. 247,814	5/1978	Johnson et al.	D15/23
D. 272,826	2/1984	Cochran et al.	D15/25
D. 284,577	7/1986	DuBose	D15/28
D. 322,792	12/1991	Park	D15/25
D. 365,578	12/1995	Westimayer et al.	D15/31
D. 376,372	12/1996	Little et al.	D15/23
D. 382,279	8/1997	Goebert	D15/31
4,055,262	10/1977	Bauer et al.	214/140
4,815,550	3/1989	Mather et al.	180/68.1

OTHER PUBLICATIONS

JCB Manutention 3, Le Robot JCB: De Multiples Utilisations, pp. 1-6, See particularly p. 3, Published in 1993 in England.

Melroe Company, Bobcat 940 Series Loader, pp. 1-4, See particularly pp. 2-3, Publish date—unknown, Published in USA.

GEHL, Gehlmax Champion Kompakt-Programm, pp. 1-4, See particularly p. 3, Publish date—unknown, Published in Germany.

Primary Examiner—Sandra L. Morris

[57] CLAIM

The ornamental design for an engine enclosure, as shown and described.

DESCRIPTION

FIG. 1 is an elevated rear perspective view of an engine enclosure showing a first embodiment of our new design, the broken line showing of the vehicle and tool being for illustrative purposes only, and forms no part of the claimed design;

FIG. 2 is an enlarged rear view of the engine enclosure design of FIG. 1;

FIG. 3 is an enlarged top view of the engine enclosure design of FIG. 1;

FIG. 4 is an enlarged right side view of the engine enclosure design of FIG. 1;

FIG. 5 is an enlarged left side view of the engine enclosure design of FIG. 1;

FIG. 6 is an enlarged rear view of an engine enclosure showing a second embodiment of our new design;

FIG. 7 is an enlarged top view of the engine enclosure design of FIG. 6;

FIG. 8 is an enlarged right side view of the engine enclosure design of FIG. 6; and,

FIG. 9 is an enlarged left side view of the engine enclosure design of FIG. 6.

1 Claim, 3 Drawing Sheets

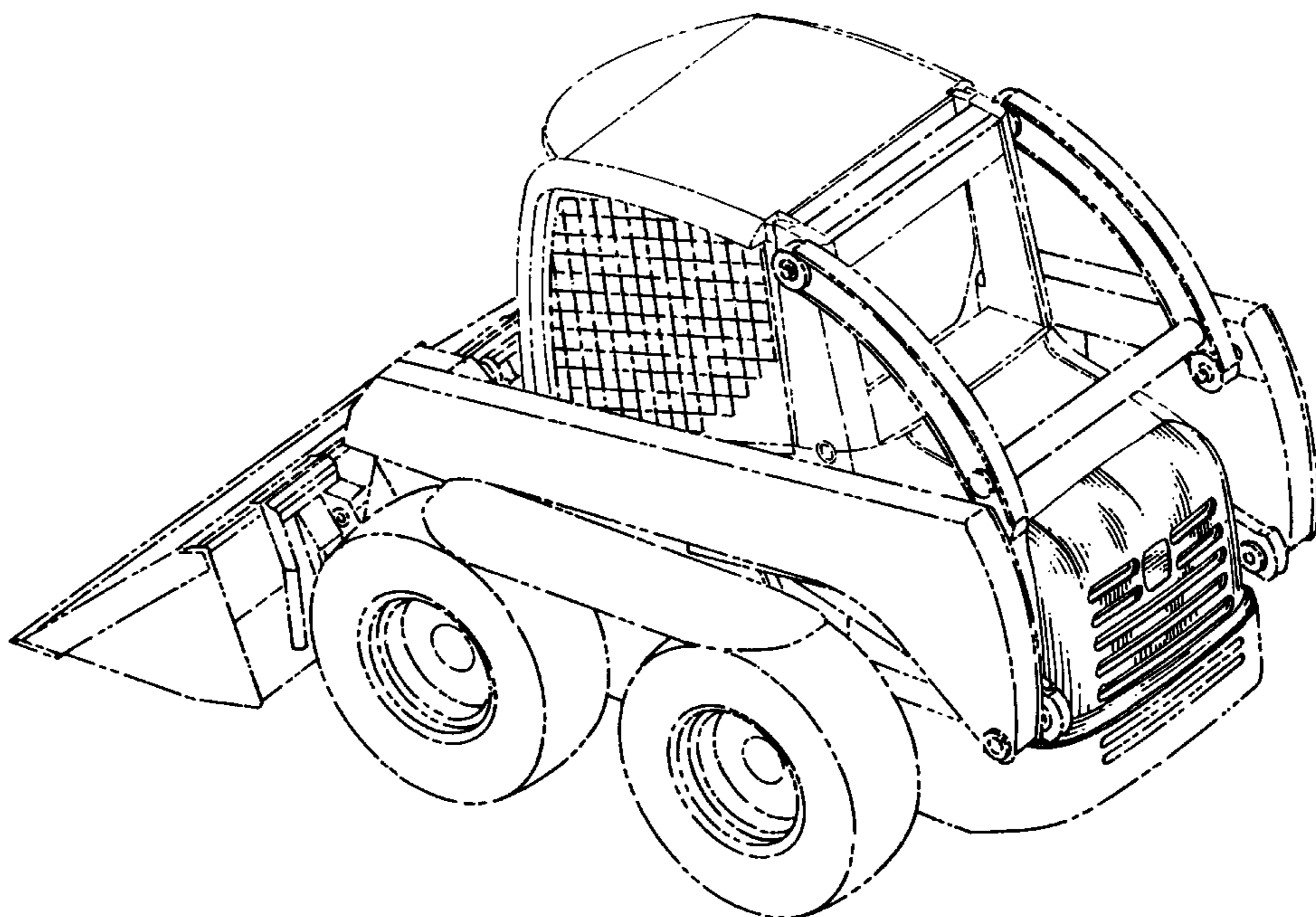

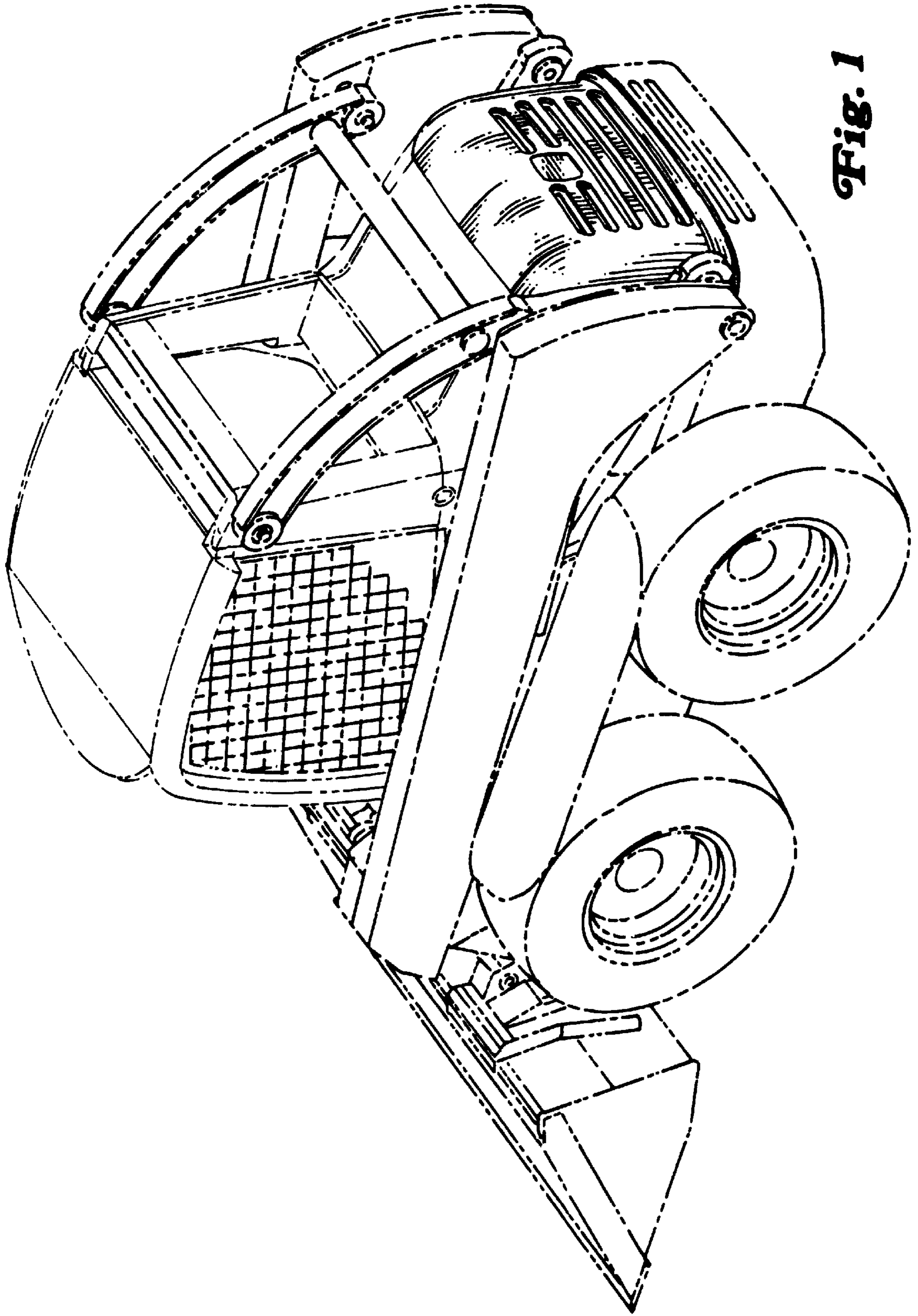

Fig. 1

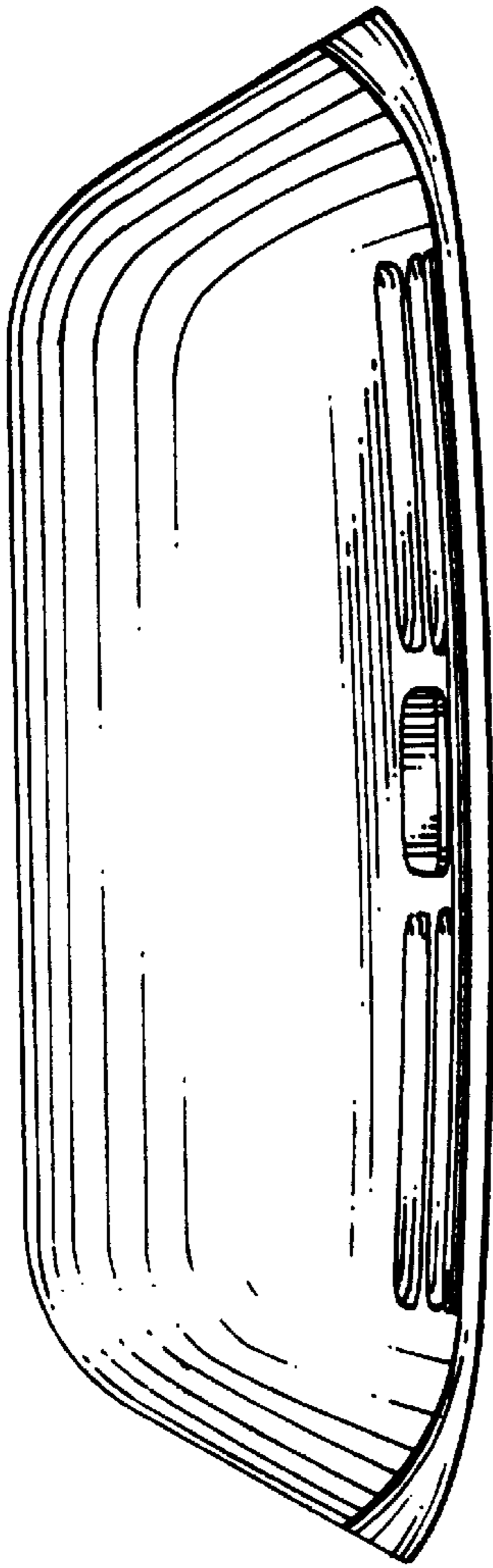

Fig. 3

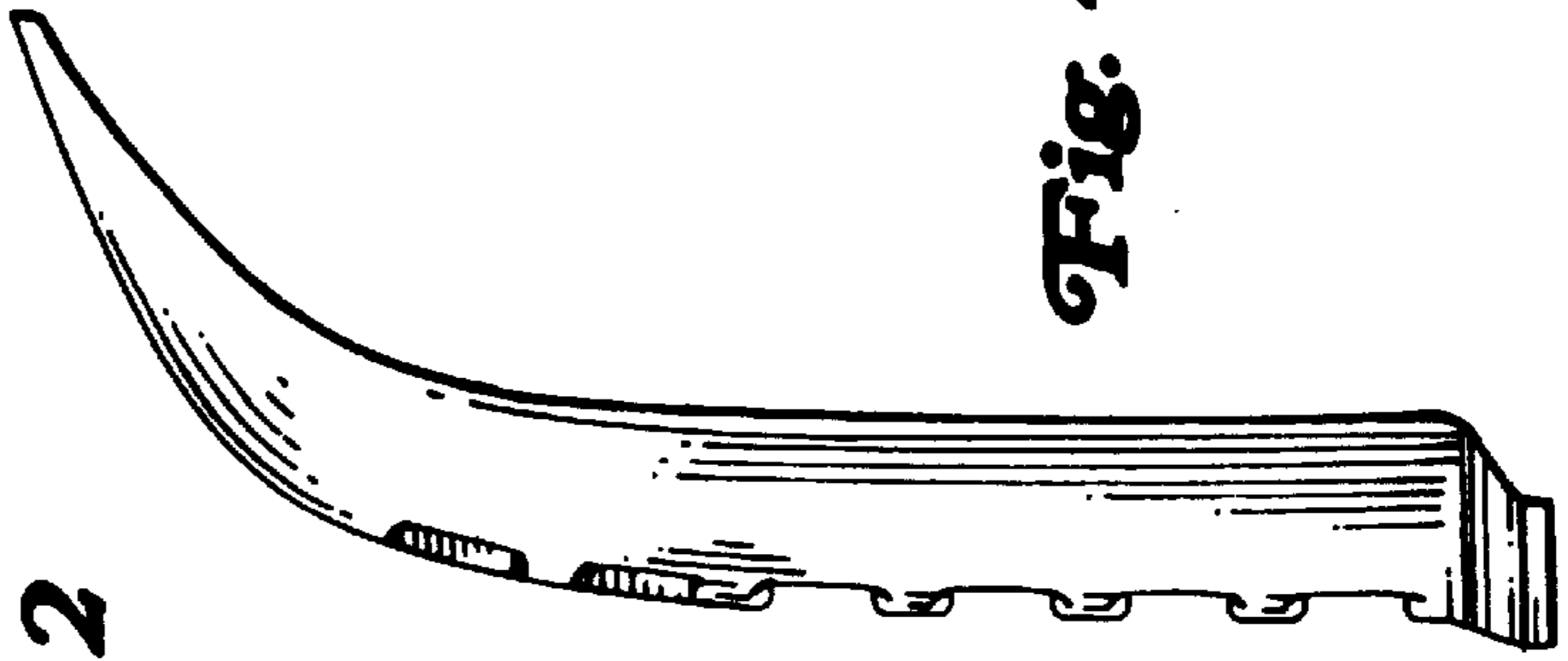

Fig. 4

Fig. 2

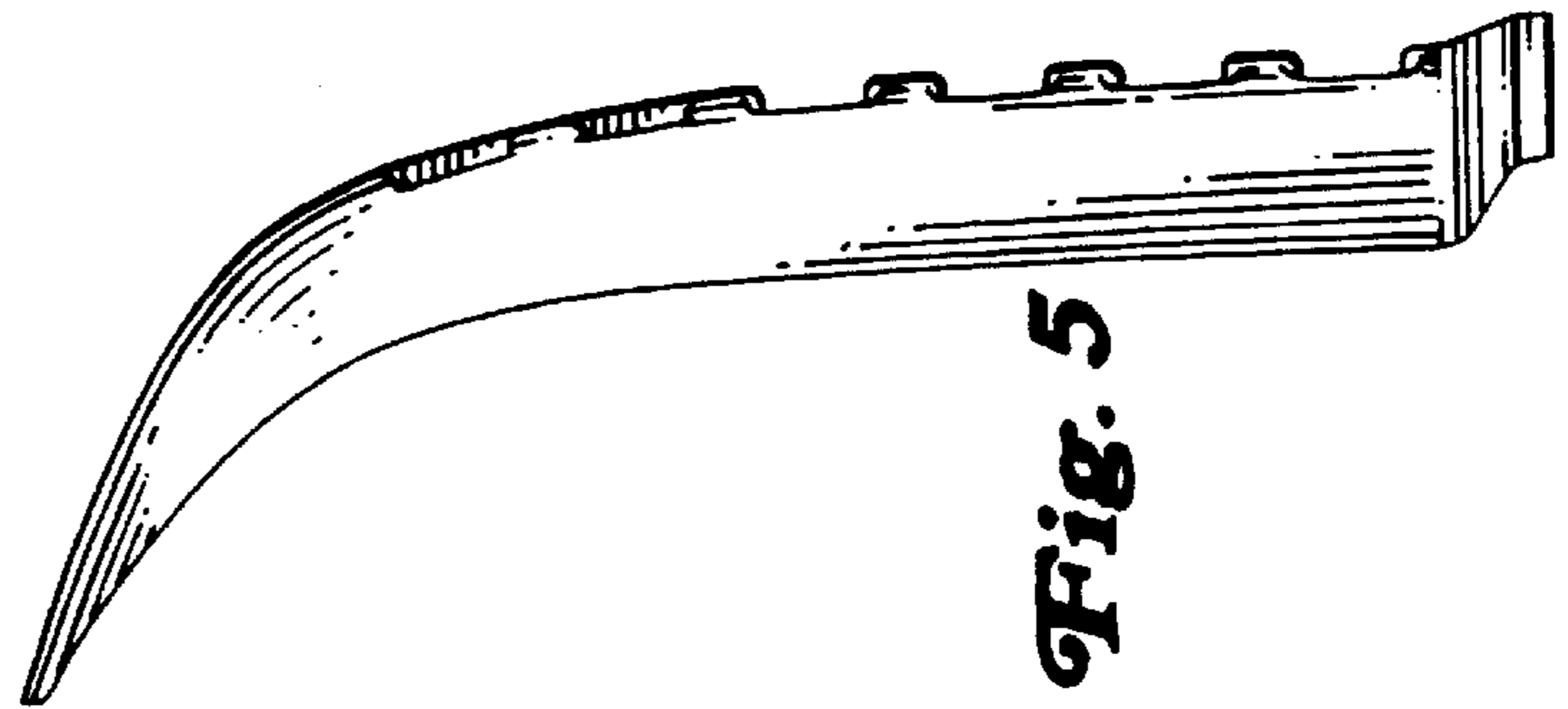
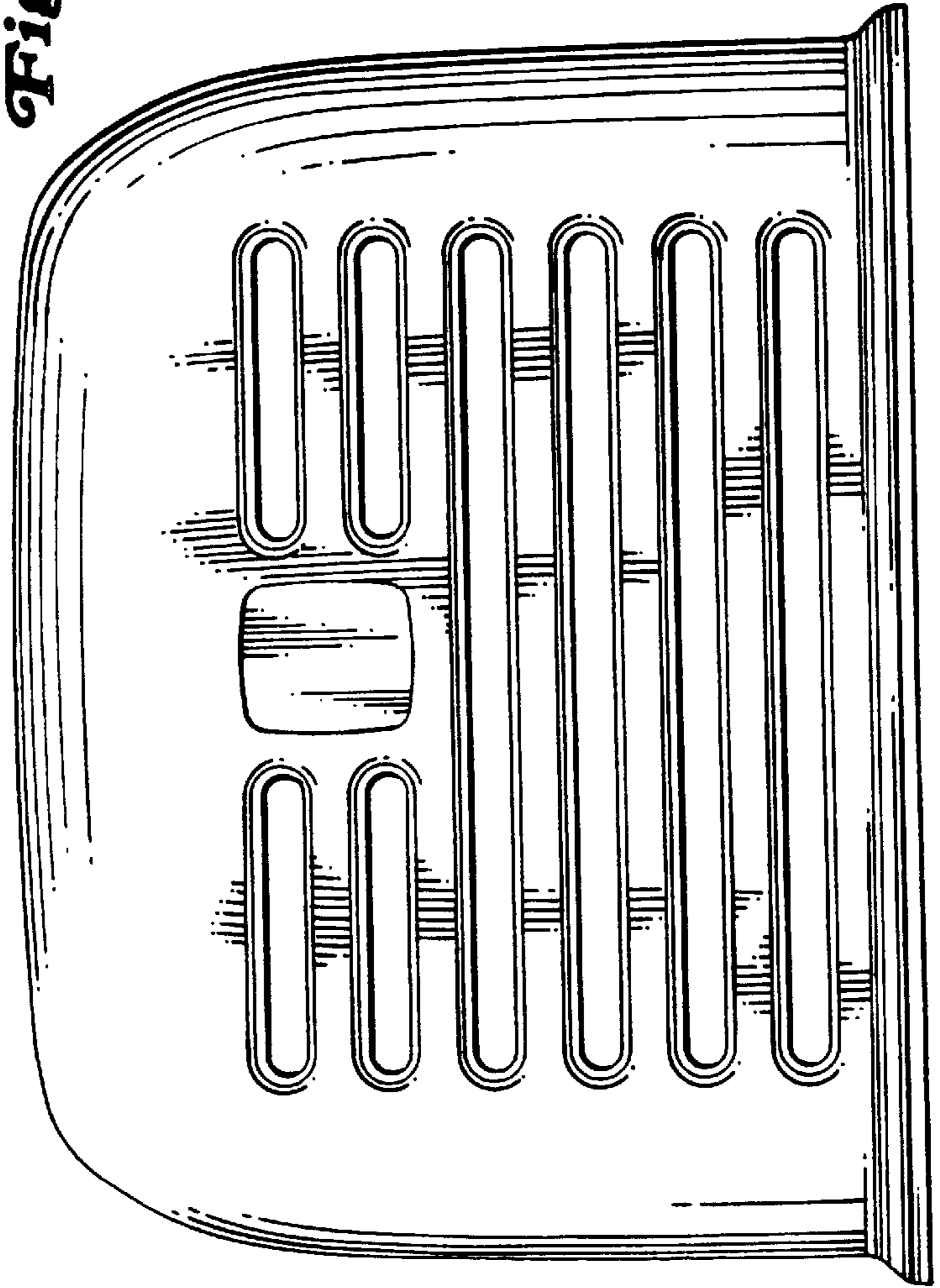

Fig. 5

