



US00D406560S

**United States Patent** [19]  
**Lindahl**

[11] **Patent Number: Des. 406,560**

[45] **Date of Patent: \*\*\*Mar. 9, 1999**

[54] **BATTERY**

D. 389,455 1/1998 Lindahl ..... D13/103

[75] Inventor: **Richard Lindahl**, Malmö, Sweden

*Primary Examiner*—Joel Sincavage

[73] Assignee: **Telefonaktiebolaget LM Ericsson**,  
Stockholm, Sweden

*Attorney, Agent, or Firm*—Burns, Doane, Swecker &  
Mathia, L.L.P.

[\*] Notice: The term of this patent shall not extend  
beyond the expiration date of Pat. No. D.  
406,097.

[57] **CLAIM**

I claim the ornamental design for the battery, as shown and  
described.

[\*\*] Term: **14 Years**

**DESCRIPTION**

[21] Appl. No.: **62,524**

FIG. 1 is a top, front, left perspective view of the battery  
incorporating my new design thereof;

[22] Filed: **Nov. 18, 1996**

FIG. 2 is a bottom, rear, right perspective view thereof;

[30] **Foreign Application Priority Data**

FIG. 3 is a bottom plan view thereof;

May 17, 1996 [SE] Sweden ..... 96-1134

FIG. 4 is a right elevational view thereof;

[51] **LOC (6) Cl.** ..... **13-02**

FIG. 5 is a top plan view thereof;

[52] **U.S. Cl.** ..... **D13/103**

FIG. 6 is a left elevational view thereof;

[58] **Field of Search** ..... D13/103, 118,  
D13/119; 429/96-100, 163, 176

FIG. 7 is a front elevational view thereof; and,

FIG. 8 is a rear elevational view thereof.

[56] **References Cited**

**U.S. PATENT DOCUMENTS**

D. 365,801 1/1996 Lindahl ..... D13/103

**1 Claim, 3 Drawing Sheets**

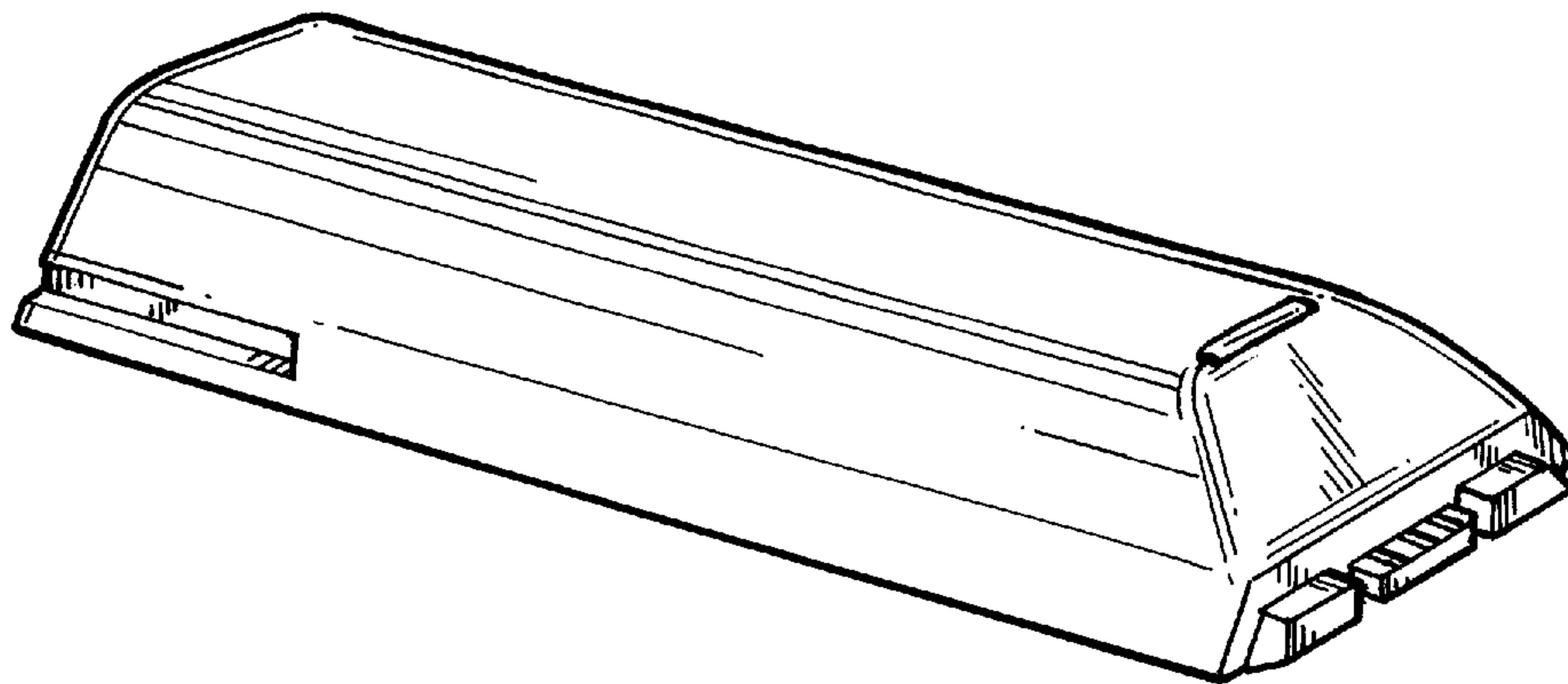

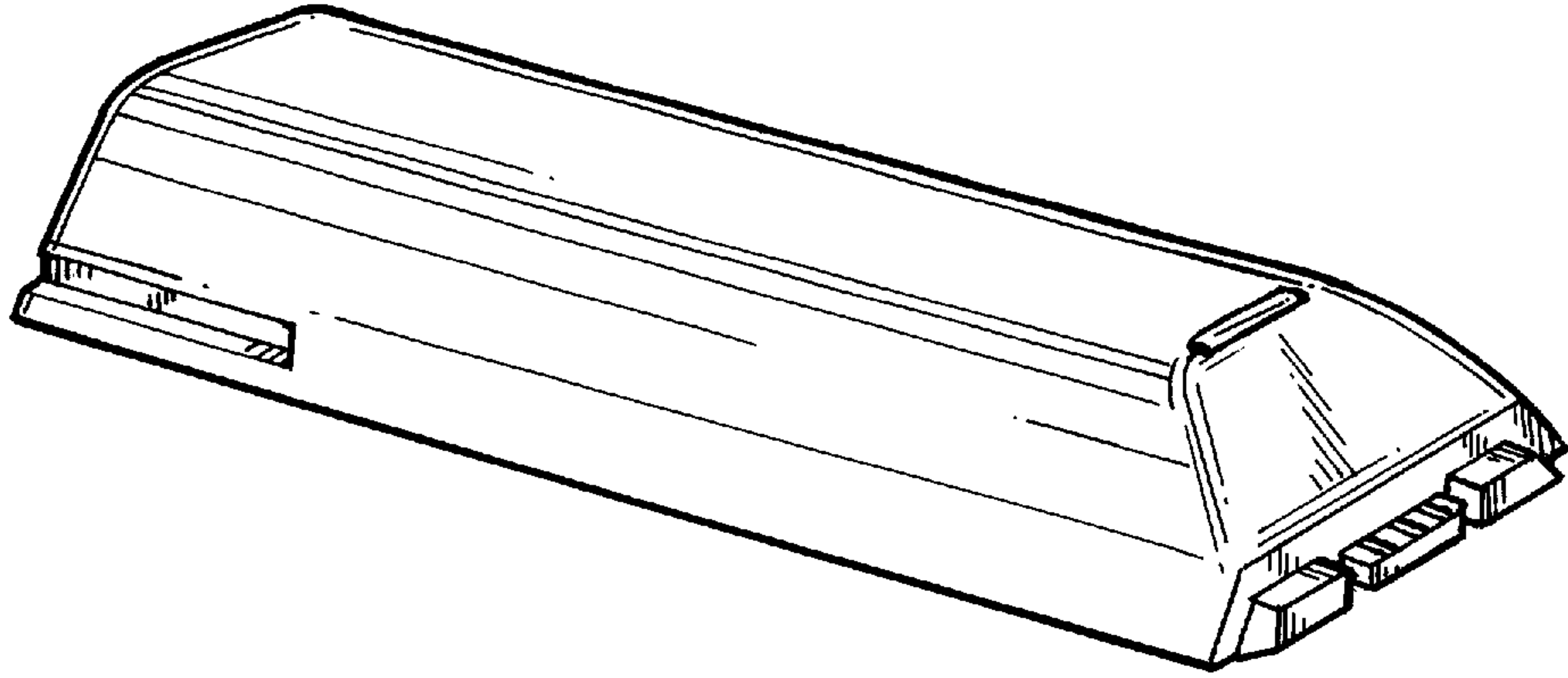

FIG. 1

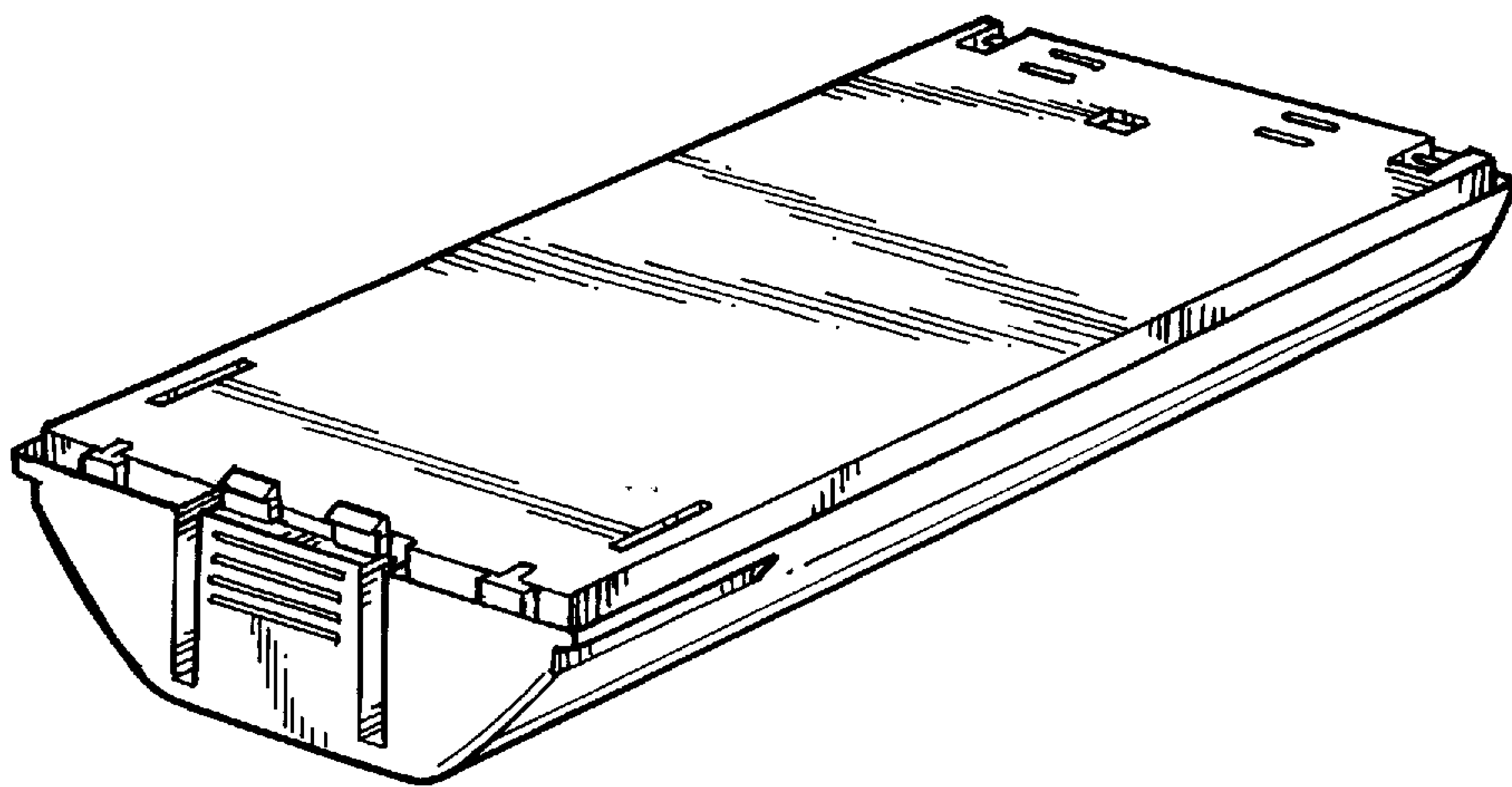

FIG. 2

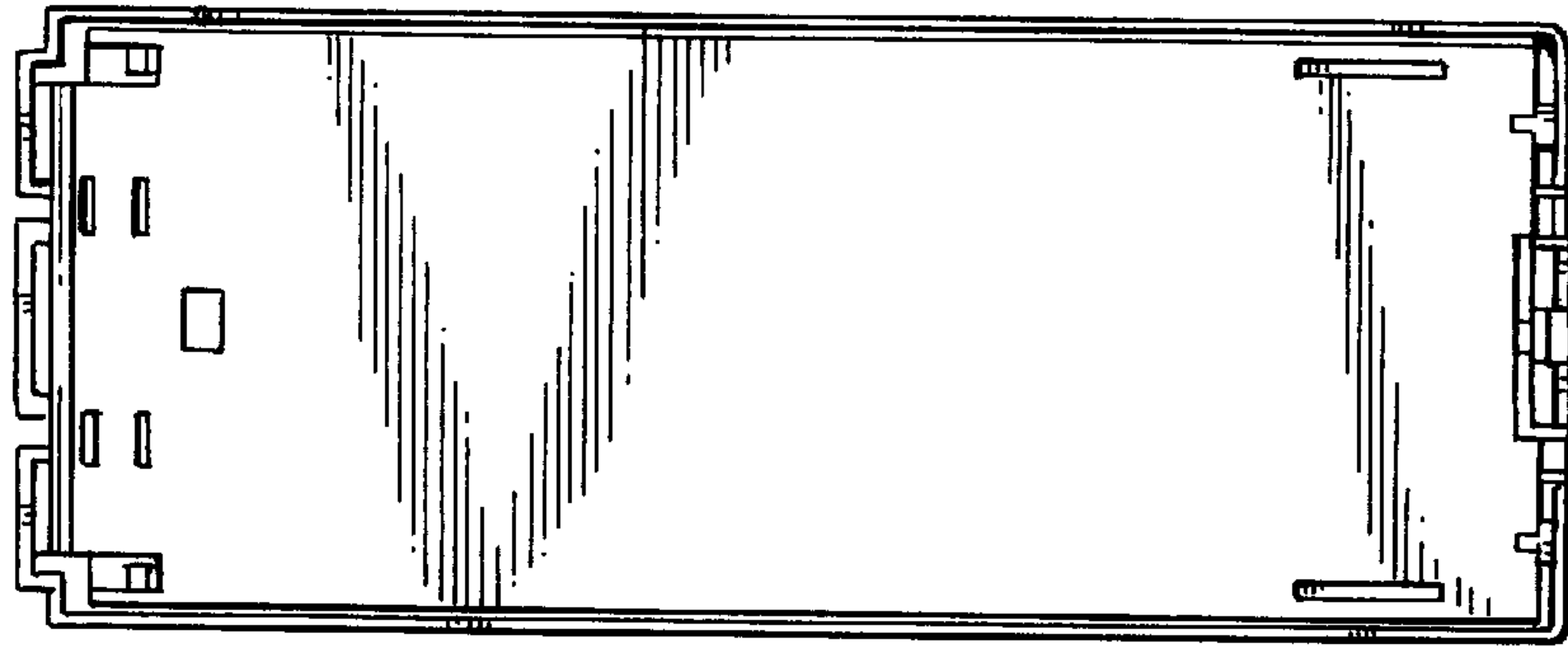

FIG. 3

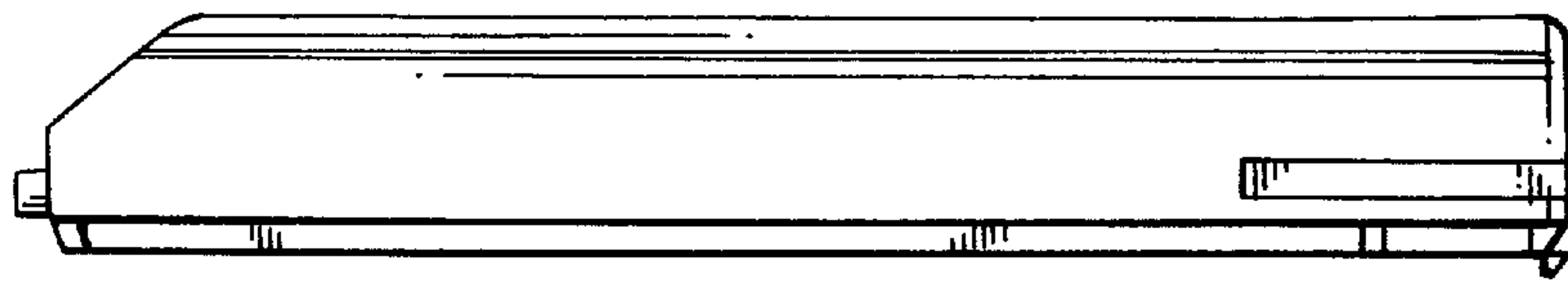

FIG. 4

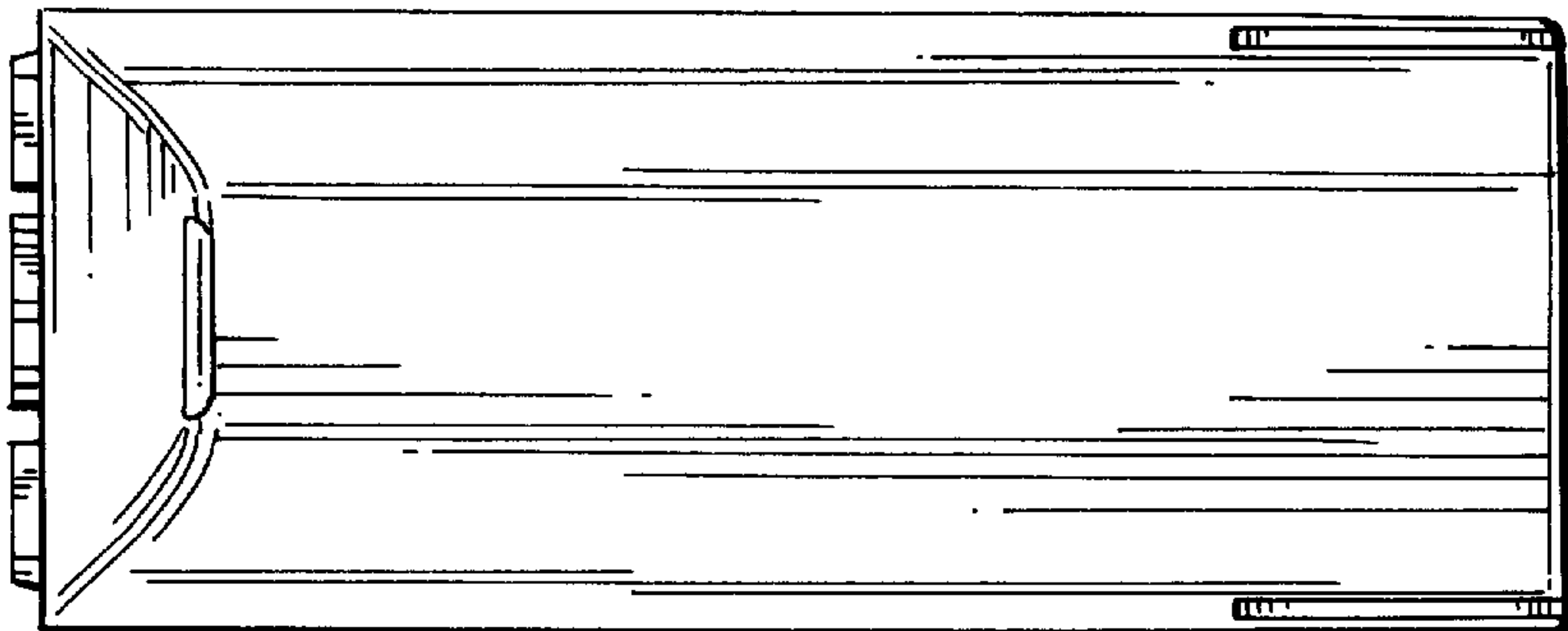

FIG. 5

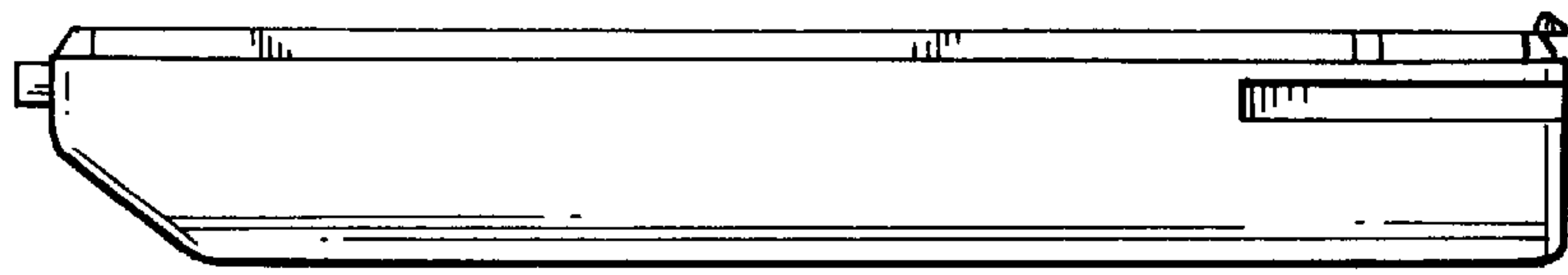

FIG. 6

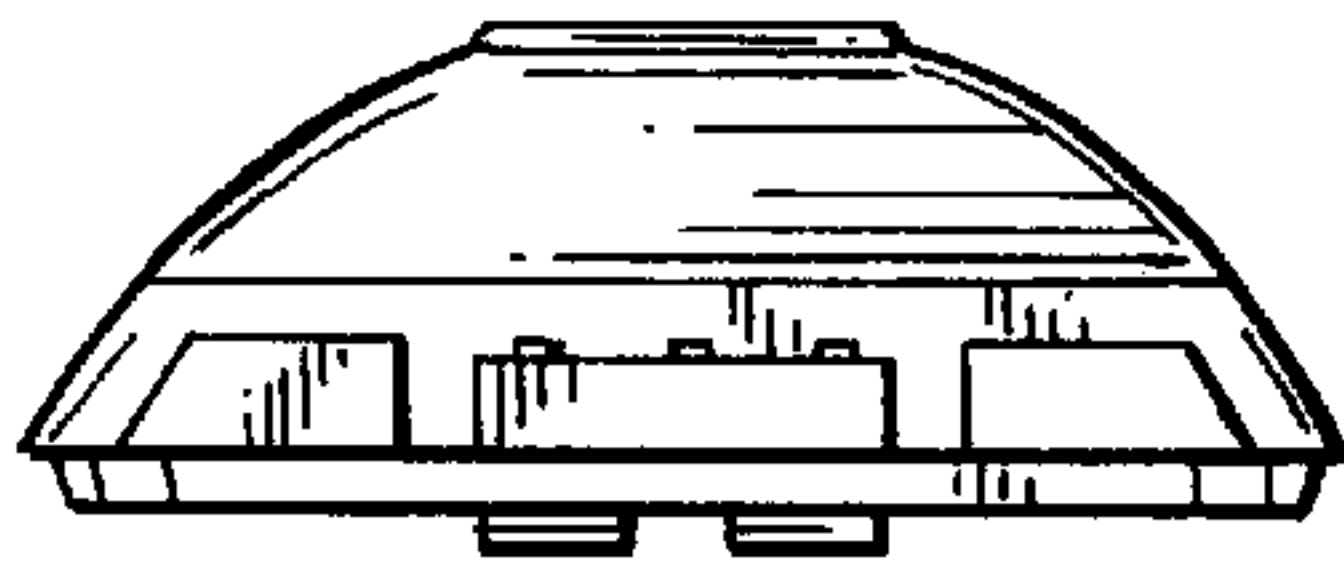

FIG. 7

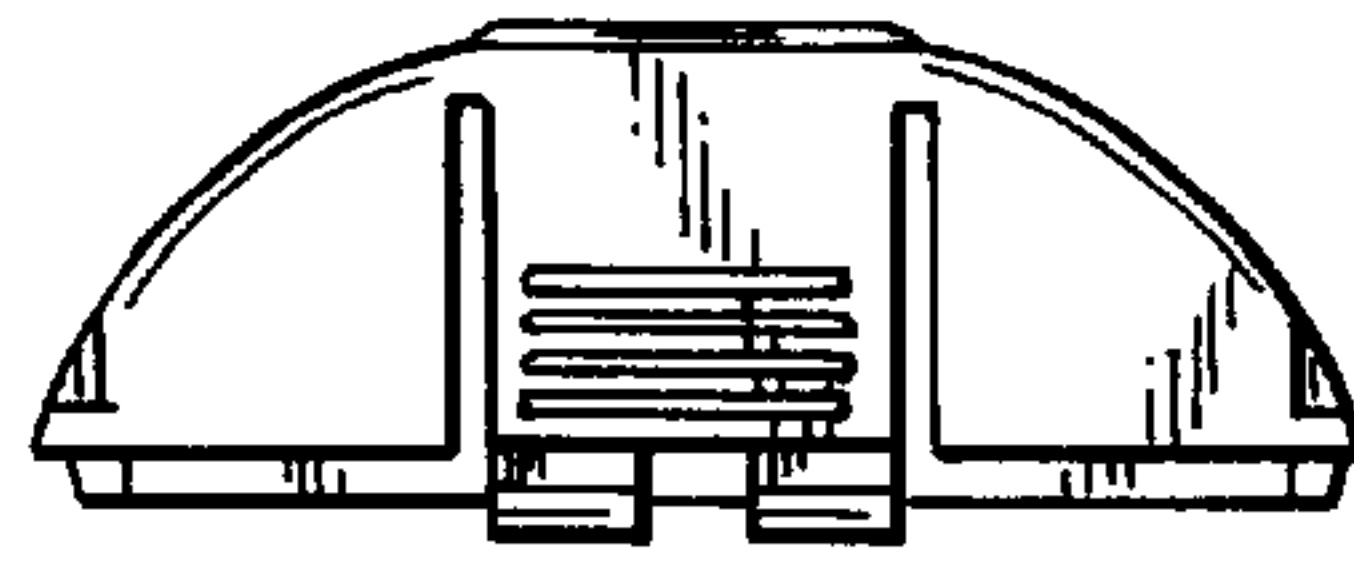

FIG. 8