

US00D406558S

United States Patent [19] Pendergraph

[11] **Patent Number: Des. 406,558**

[45] **Date of Patent: **Mar. 9, 1999**

[54] **VEHICLE-TOP CARGO CARRIER**

[76] Inventor: **David E. Pendergraph**, R.D. 2, Box 330, Sam Adams La., Auburn, N.Y. 13021

[**] Term: **14 Years**

[21] Appl. No.: **81,127**

[22] Filed: **Dec. 23, 1997**

[51] **LOC (6) Cl. 12-16**

[52] **U.S. Cl. D12/413**

[58] **Field of Search** D12/400, 401, D12/404, 406, 412, 413; 296/99.1, 37.7, 37.1; 224/309, 310, 314, 320-323

[56] **References Cited**

U.S. PATENT DOCUMENTS

D. 269,667	7/1983	Taylor et al.	D12/413
D. 279,972	8/1985	Marovich	D12/413
D. 295,620	5/1988	Littrell	D12/413
D. 297,630	9/1988	Breger	D12/413
D. 299,914	2/1989	Witte	D12/413
D. 306,571	3/1990	Mount	D12/413
D. 312,432	11/1990	Lewis	D12/413
D. 317,429	6/1991	Seaver	D12/413
D. 326,634	6/1992	Seaver	D12/413
D. 337,086	7/1993	Theodorsen	D12/413
D. 342,049	12/1993	Harrison	D12/413

Primary Examiner—James Gandy
Assistant Examiner—Stacia Sinuik
Attorney, Agent, or Firm—Lerner, David, Littenberg, Krumholz & Mentlik

[57] **CLAIM**

The ornamental design for a vehicle-top cargo carrier, as shown and described.

DESCRIPTION

FIG. 1 is a perspective view, taken from the left and slightly above, of a vehicle-top cargo carrier showing my new design, and showing a vehicle in broken lines;
FIG. 2 is a top plan view taken from FIG. 1;
FIG. 3 is a bottom view taken from FIG. 1;
FIG. 4 is a right side elevational view taken from FIG. 1;
FIG. 5 is a rear elevational view, taken from FIG. 1;
FIG. 6 is a front elevational view, taken from FIG. 1; and,
FIG. 7 is a perspective view taken from the left and slightly above, of a vehicle-top cargo carrier according to my new design, shown in an open configuration.
The portion of the interior not shown in FIG. 7 forms no part of the claimed design.
The broken line showing of environment is for illustrative purposes only and forms no part of the claimed design.
The left side elevational view of the vehicle-top cargo carrier is partially shown in FIG. 1 and is understood to be a mirror image of the right side elevational view.

1 Claim, 4 Drawing Sheets

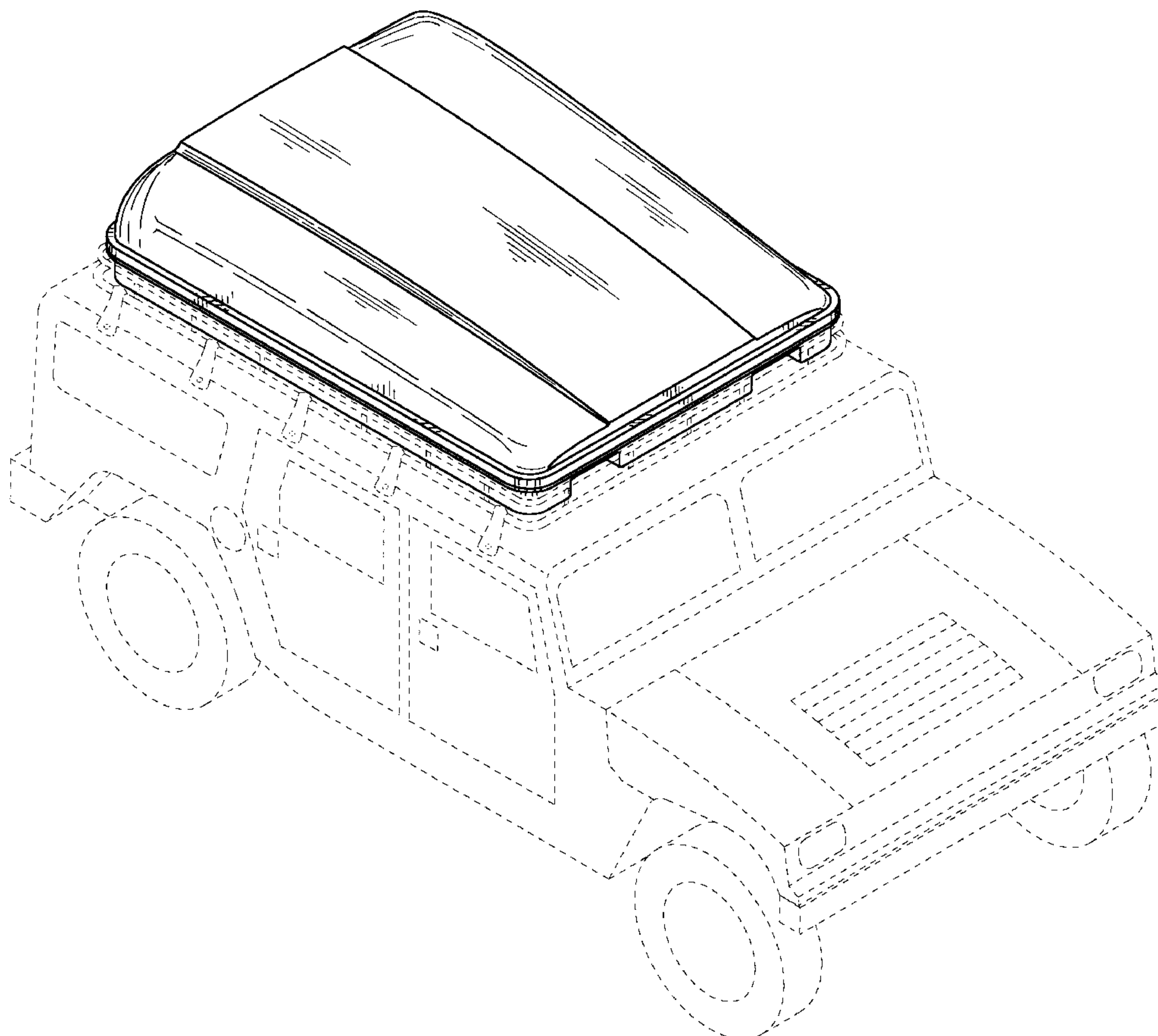

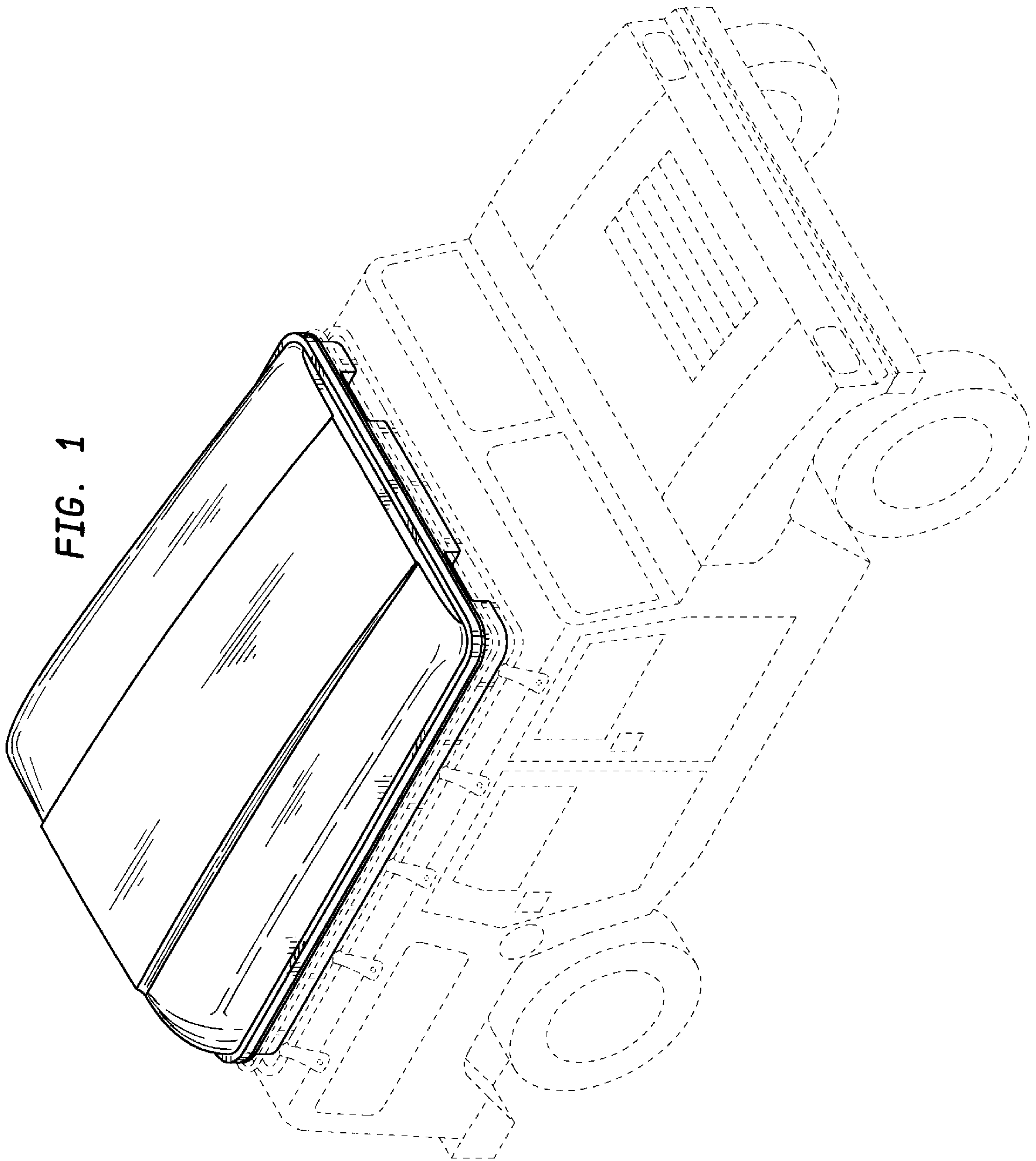

FIG. 2

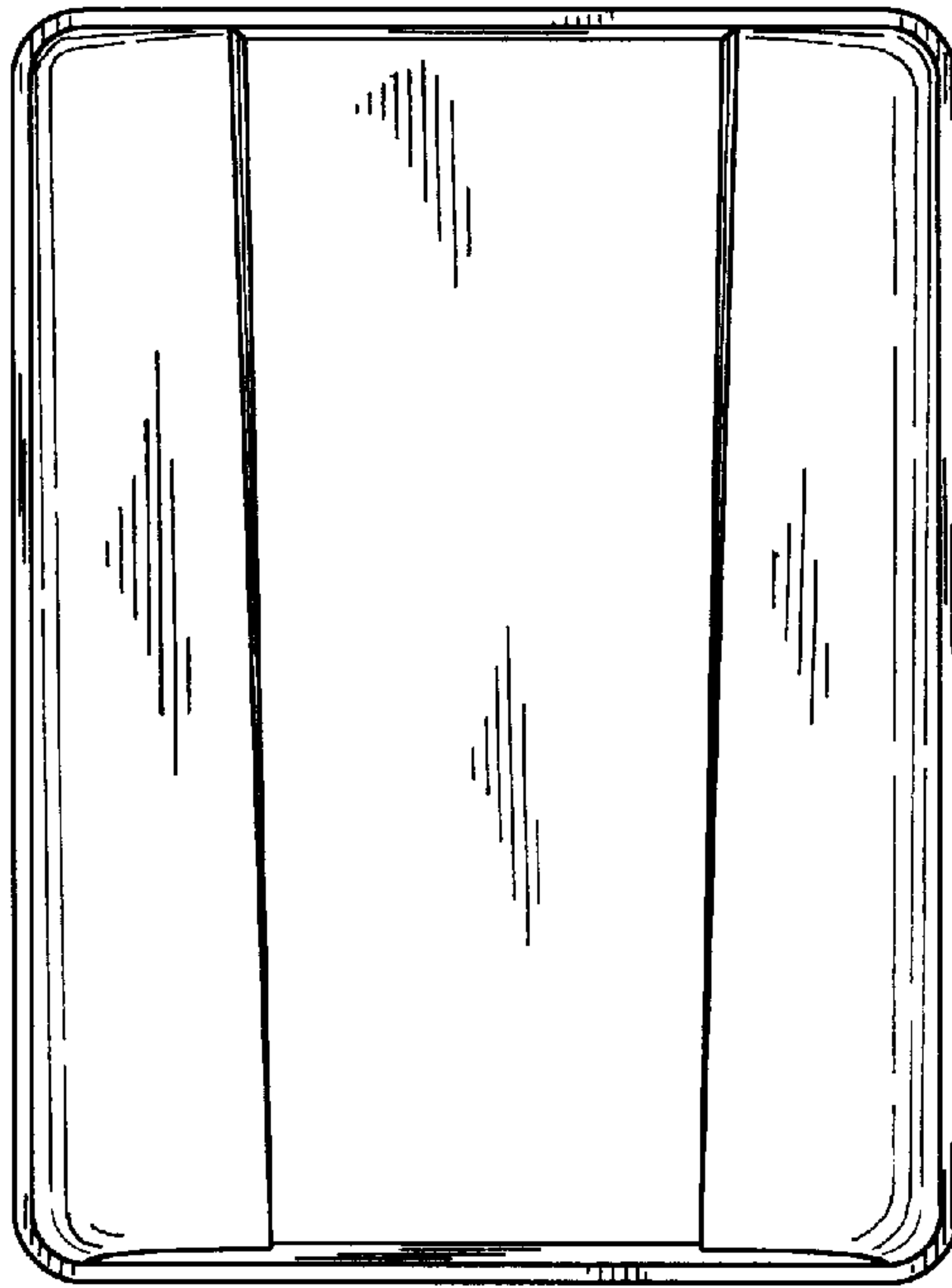

FIG. 3

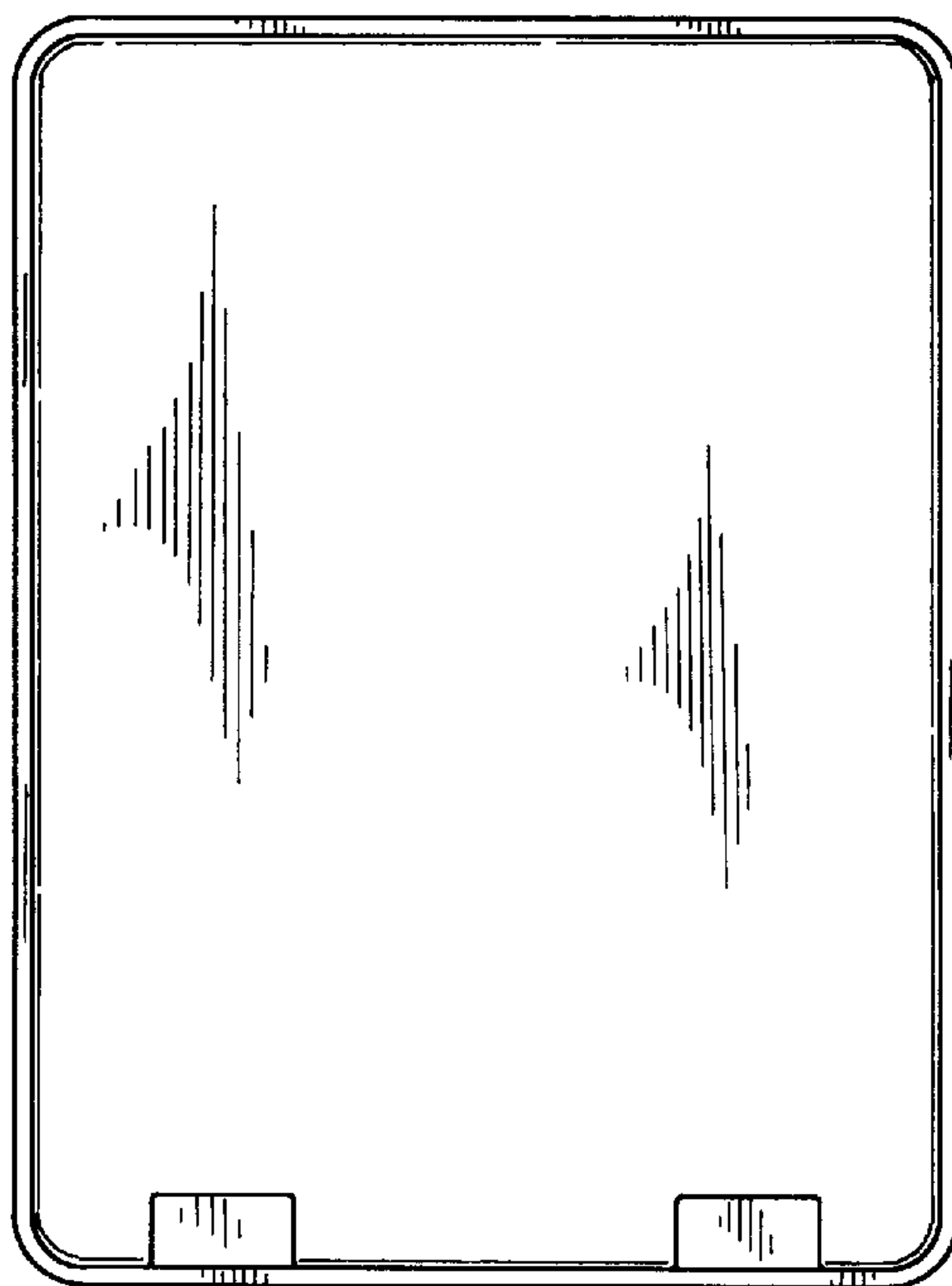

FIG. 4

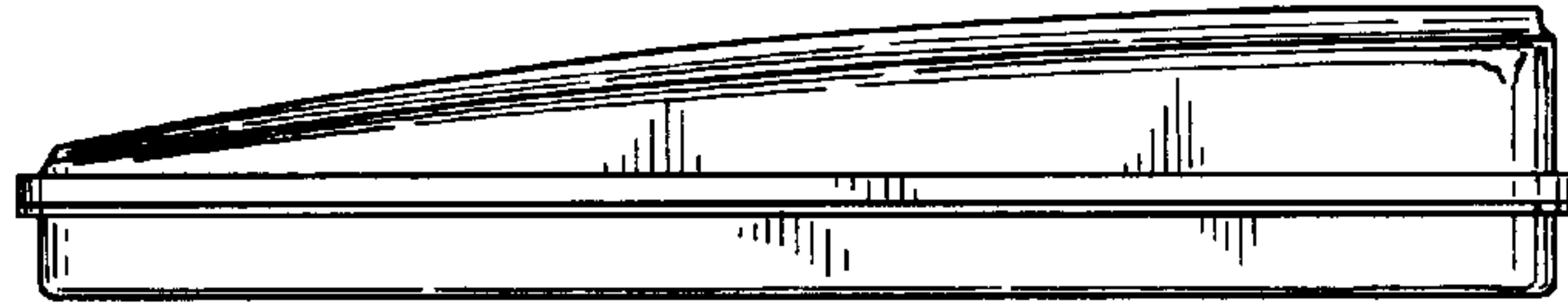

FIG. 5



FIG. 6

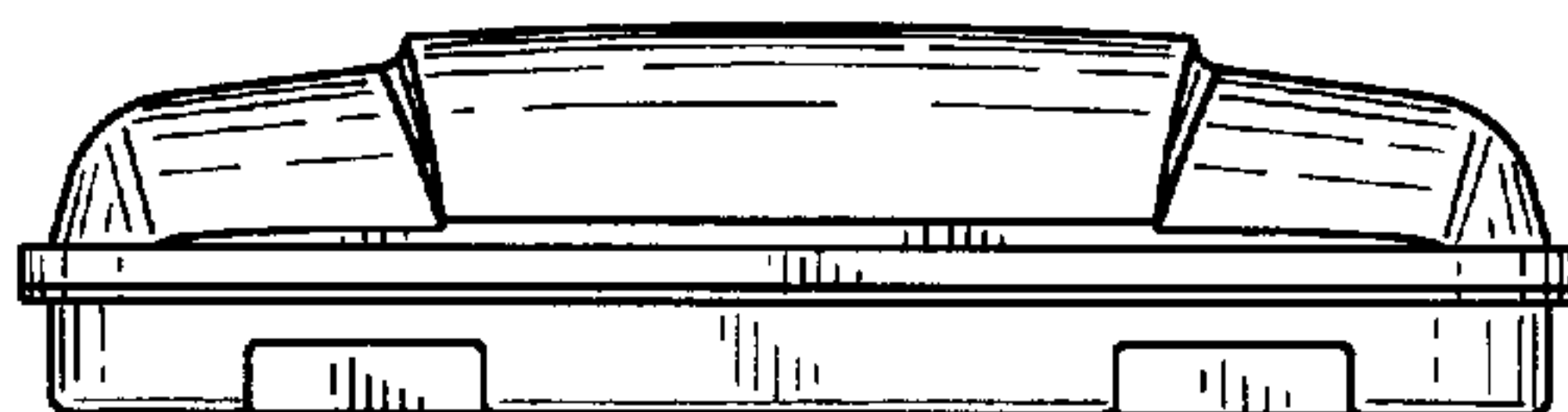

FIG. 7

