



US00D406543S

United States Patent [19]

[11] **Patent Number: Des. 406,543**

Brown et al.

[45] **Date of Patent: **Mar. 9, 1999**

[54] **TRAFFIC CHANNELIZER**

5,234,280 8/1993 Cowan .
5,560,732 10/1996 Kulp et al. .

[75] Inventors: **Gregory H. Brown**, Stow; **David E. Cowan**, Orange Village; **David A. Cowan**, Pepper Pike, all of Ohio

OTHER PUBLICATIONS

1. Brochure entitled Top Stackable Channelizer Cone, prior to Apr. 15, 1998.
2. Brochure entitled New Grabber Vertical Panel Barricade, prior to Apr. 15, 1998.

[73] Assignee: **Plastic Safety Systems, Inc.**,
Cleveland, Ohio

[**] Term: **14 Years**

Primary Examiner—Marcus A. Jackson
Attorney, Agent, or Firm—Renner, Otto, Boisselle & Sklar, P.L.L.

[21] Appl. No.: **86,542**

[22] Filed: **Apr. 15, 1998**

[57] CLAIM

[51] **LOC (6) Cl.** **10-05**

The ornamental design for a traffic channelizer, as shown and described.

[52] **U.S. Cl.** **D10/113**

[58] **Field of Search** D10/109, 111,
D10/113, 114; 116/63 C, 63 P; 404/4-16;
40/611, 612

DESCRIPTION

FIG. 1 is a perspective view of a traffic channelizer showing our new design;
 FIG. 2 is a side elevation view thereof from the right side of FIG.1, the left side being a mirror image thereof;
 FIG. 3 is a front elevation view thereof, the rear elevation view being a mirror image;
 FIG. 4 is a top plan view thereof; and,
 FIG. 5 is a bottom plan view thereof.

[56] References Cited

U.S. PATENT DOCUMENTS

D. 310,642	9/1990	Kulp .	
D. 338,631	8/1993	Braverman	D10/113
3,380,428	4/1968	Abrams	116/63 P
4,925,334	5/1990	Beard .	
5,036,791	8/1991	Thurston .	

1 Claim, 2 Drawing Sheets

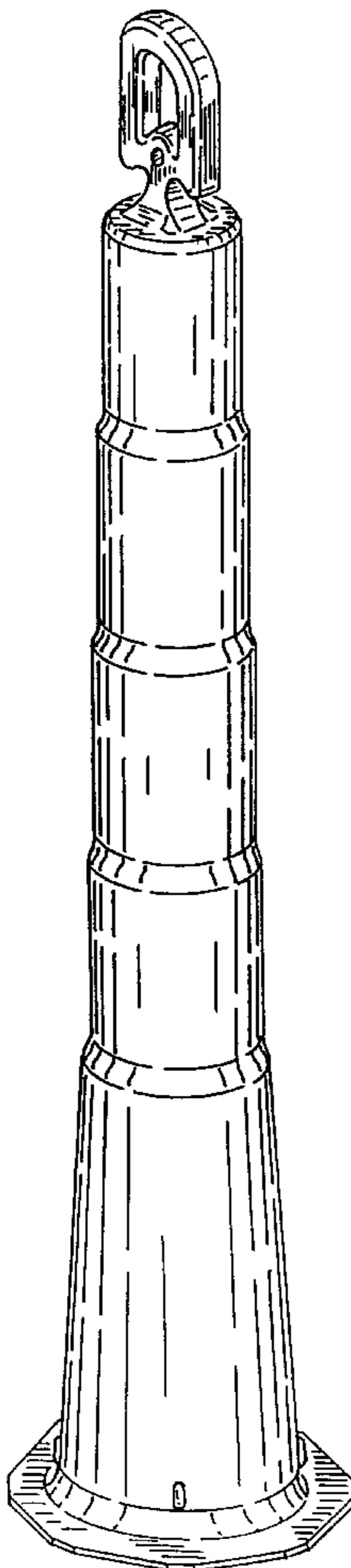

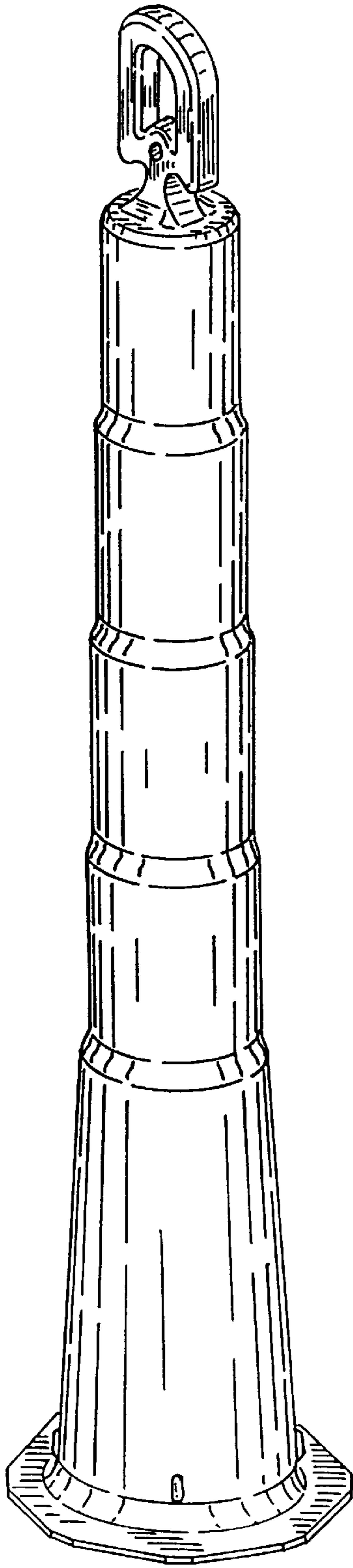

FIG. 1

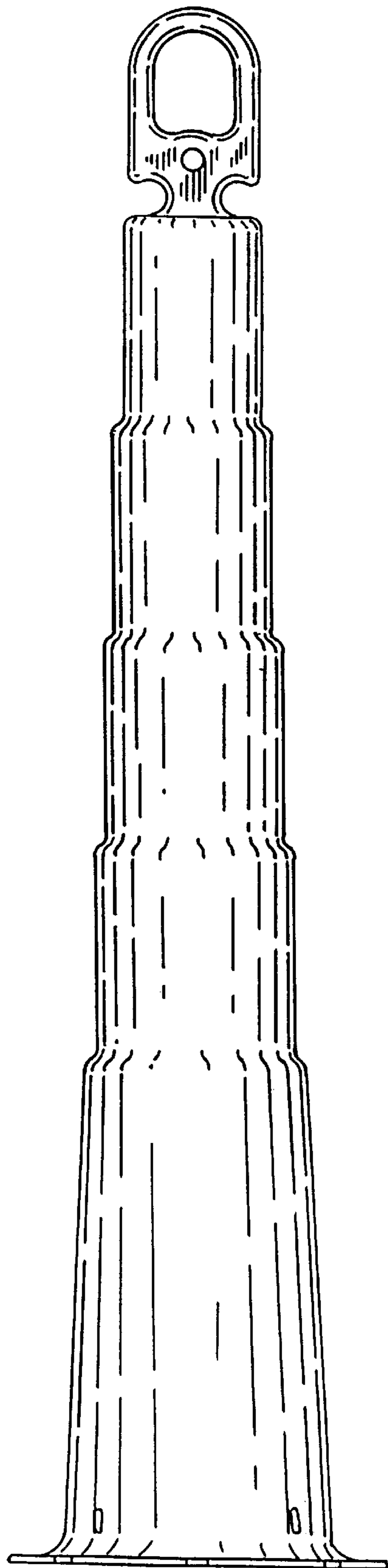

FIG. 2

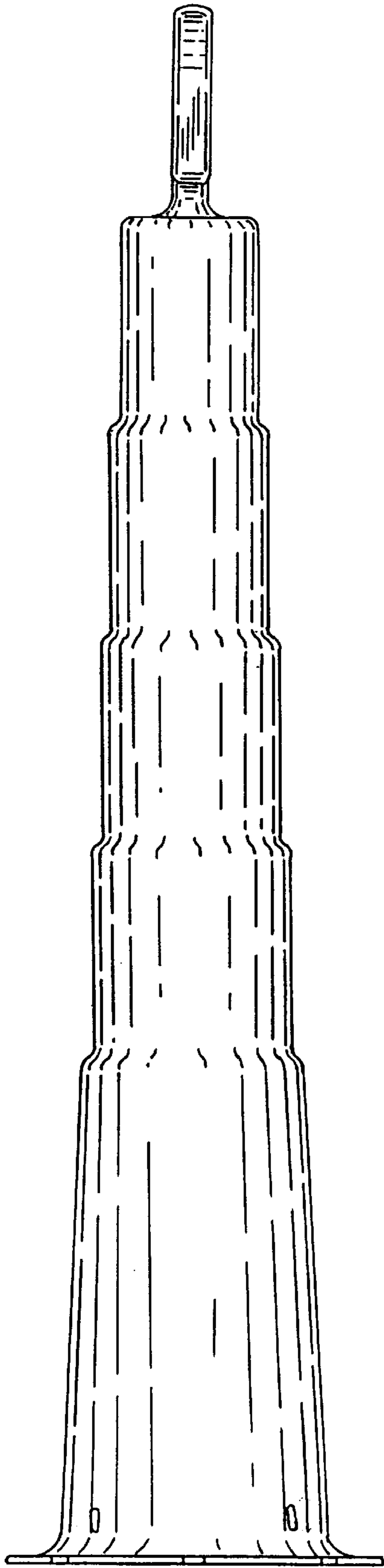

FIG. 3

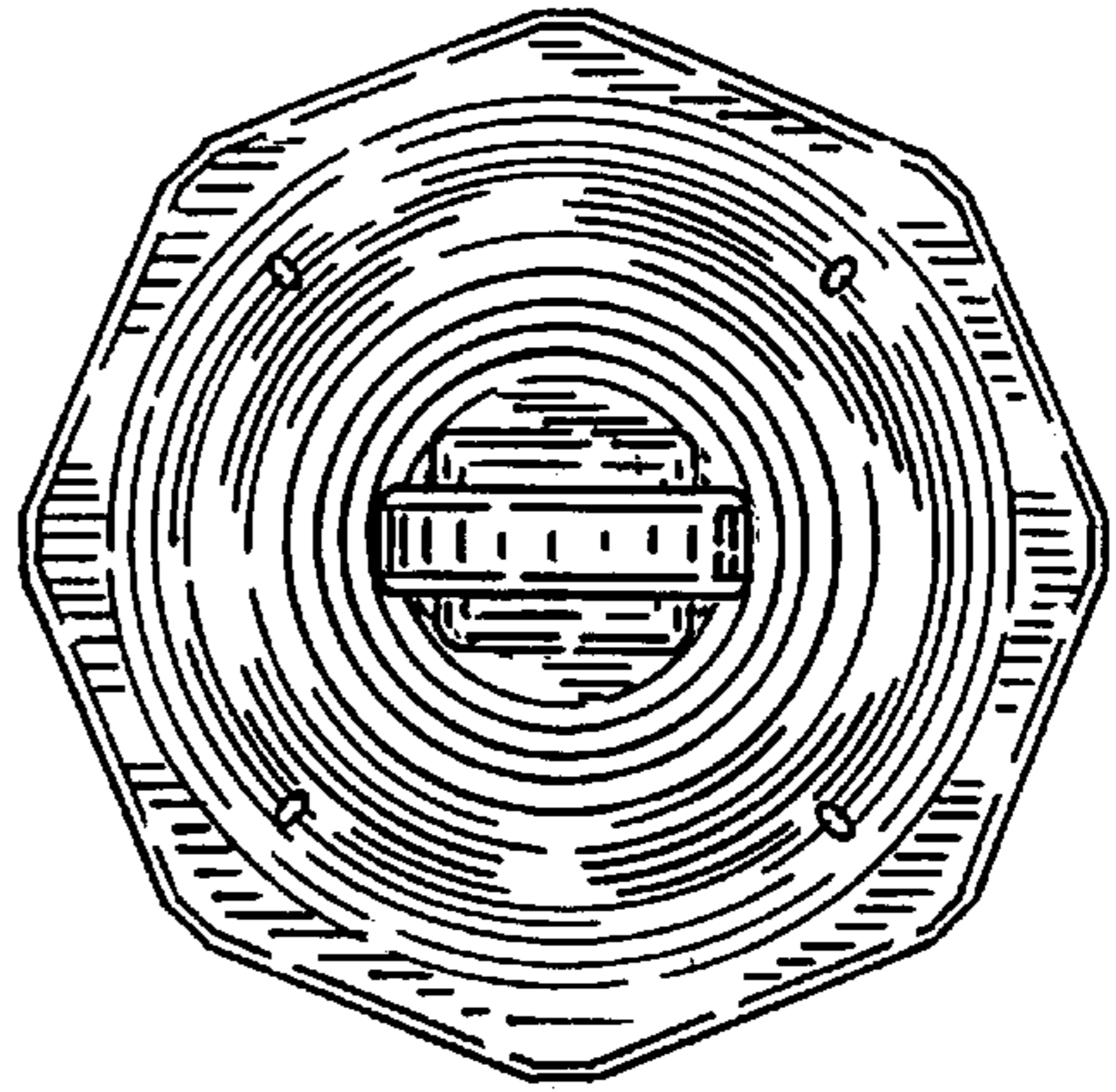

FIG. 4

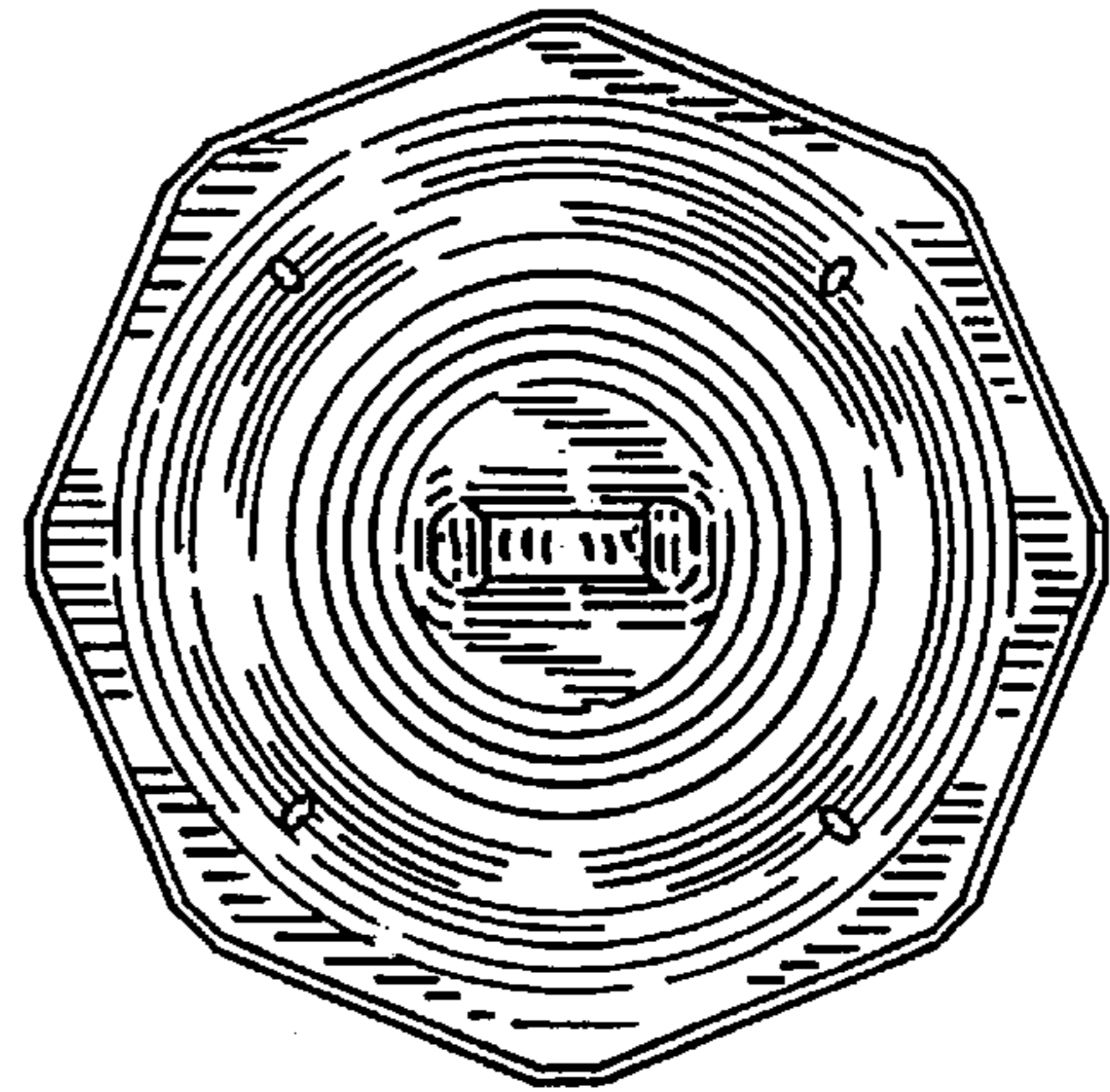

FIG. 5