



US00D406523S

United States Patent [19]
Manthei

[11] **Patent Number: Des. 406,523**
[45] **Date of Patent: **Mar. 9, 1999**

[54] **PICK UP TRUCK CARGO TIE DOWN**

DESCRIPTION

[76] Inventor: **Robert Carl Manthei**, 5114 Bloch St.,
San Diego, Calif. 92122

[**] Term: **14 Years**

[21] Appl. No.: **84,656**

[22] Filed: **Mar. 6, 1998**

[51] **LOC (6) Cl.** **08-05**

[52] **U.S. Cl.** **D8/354**

[58] **Field of Search** D8/349, 354, 356;
248/499; 24/129 R, 129 D, 115 H, 16 PB

[56] **References Cited**

U.S. PATENT DOCUMENTS

D. 300,721	4/1989	Whitley, II	D8/356
4,757,969	7/1988	Tolfsen	248/499
5,477,801	12/1995	Lawrence	114/218

OTHER PUBLICATIONS

Nicro-Fico catalog p. 104, cleat, circled at right of page, Jan. 1988.

Primary Examiner—Holly Baynham

[57] **CLAIM**

I claim the ornamental design for a pickup truck cargo tiedown, as shown and described.

FIG. 1 is a perspective view;
 FIG. 2 is a right elevation view.
 FIG. 3 is a front elevation;
 FIG. 4 is a left side elevation;
 FIG. 5 is a rear elevation;
 FIG. 6 is a top view;
 FIG. 7 is a bottom view;
 FIG. 8 is a perspective view of a second embodiment of the design shown in FIG. 1;
 FIG. 9 is a right elevation;
 FIG. 10 is a front elevation;
 FIG. 11 is a left side elevation;
 FIG. 12 is a rear elevation;
 FIG. 13 is a top view;
 FIG. 14 is a bottom view;
 FIG. 15 is a perspective view of a third embodiment of the design shown in FIG. 1;
 FIG. 16 is a right side elevation;
 FIG. 17 is a front elevation;
 FIG. 18 is a left side elevation;
 FIG. 19 is a rear elevation;
 FIG. 20 is a top view; and,
 FIG. 21 is a bottom view.

1 Claim, 6 Drawing Sheets

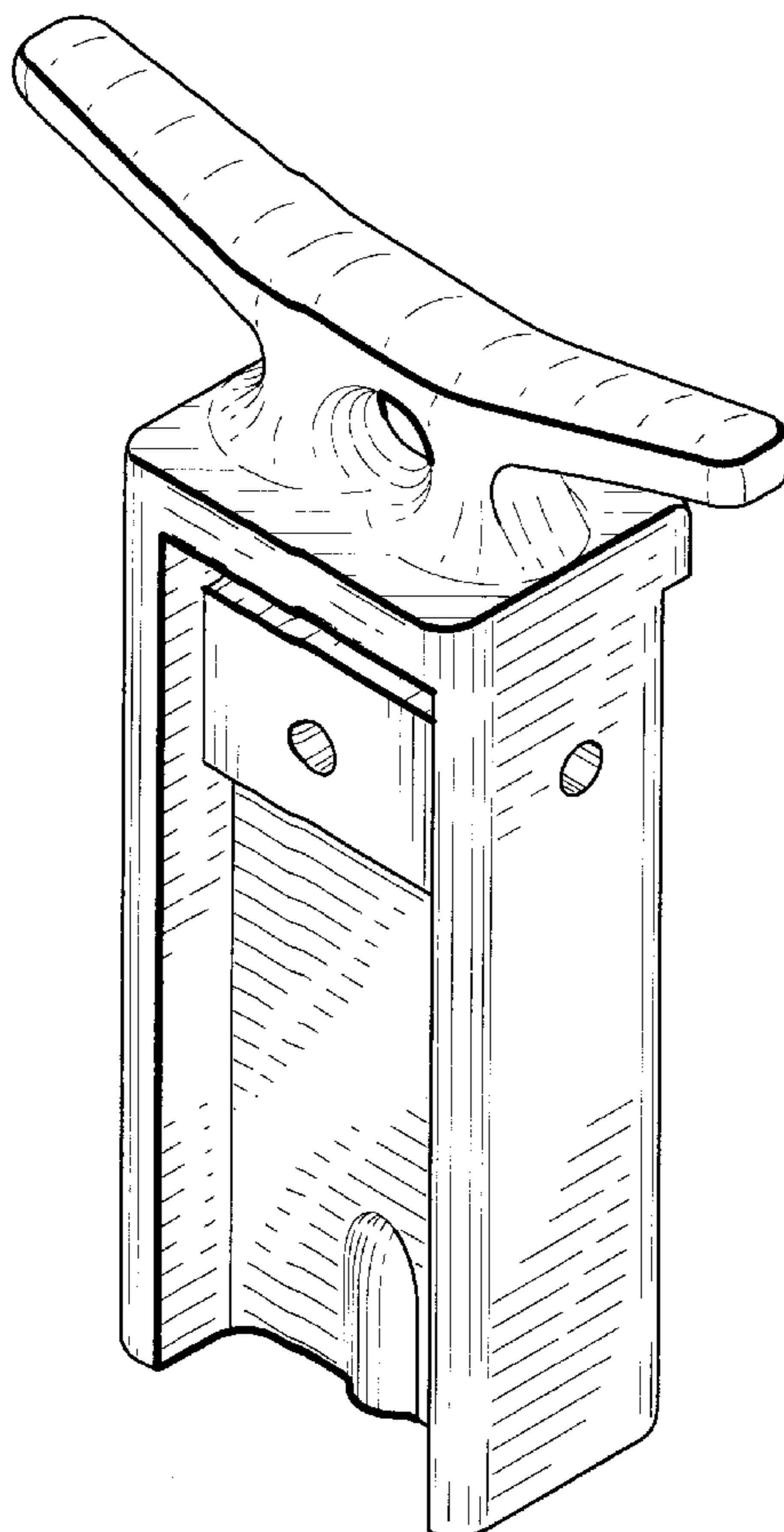

FIG. 3

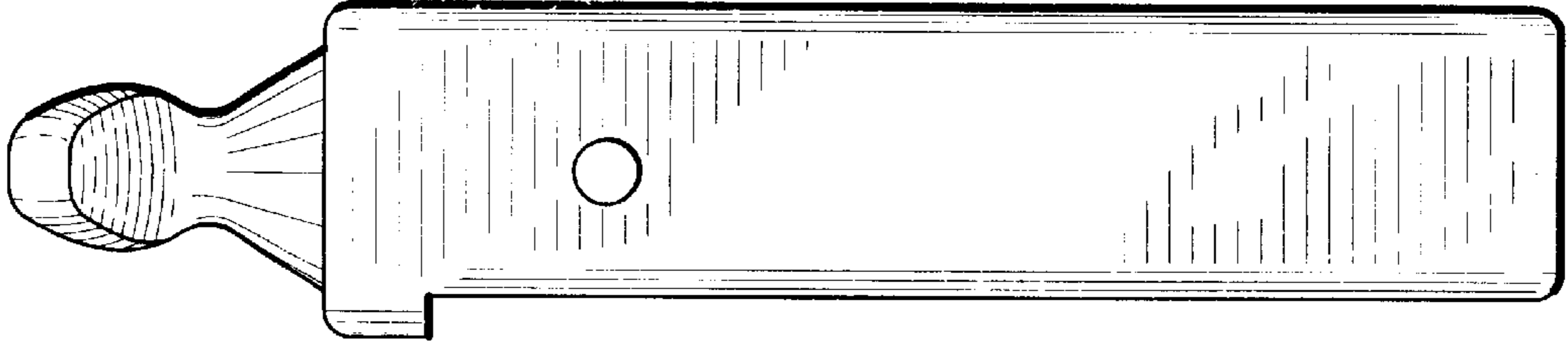

FIG. 2

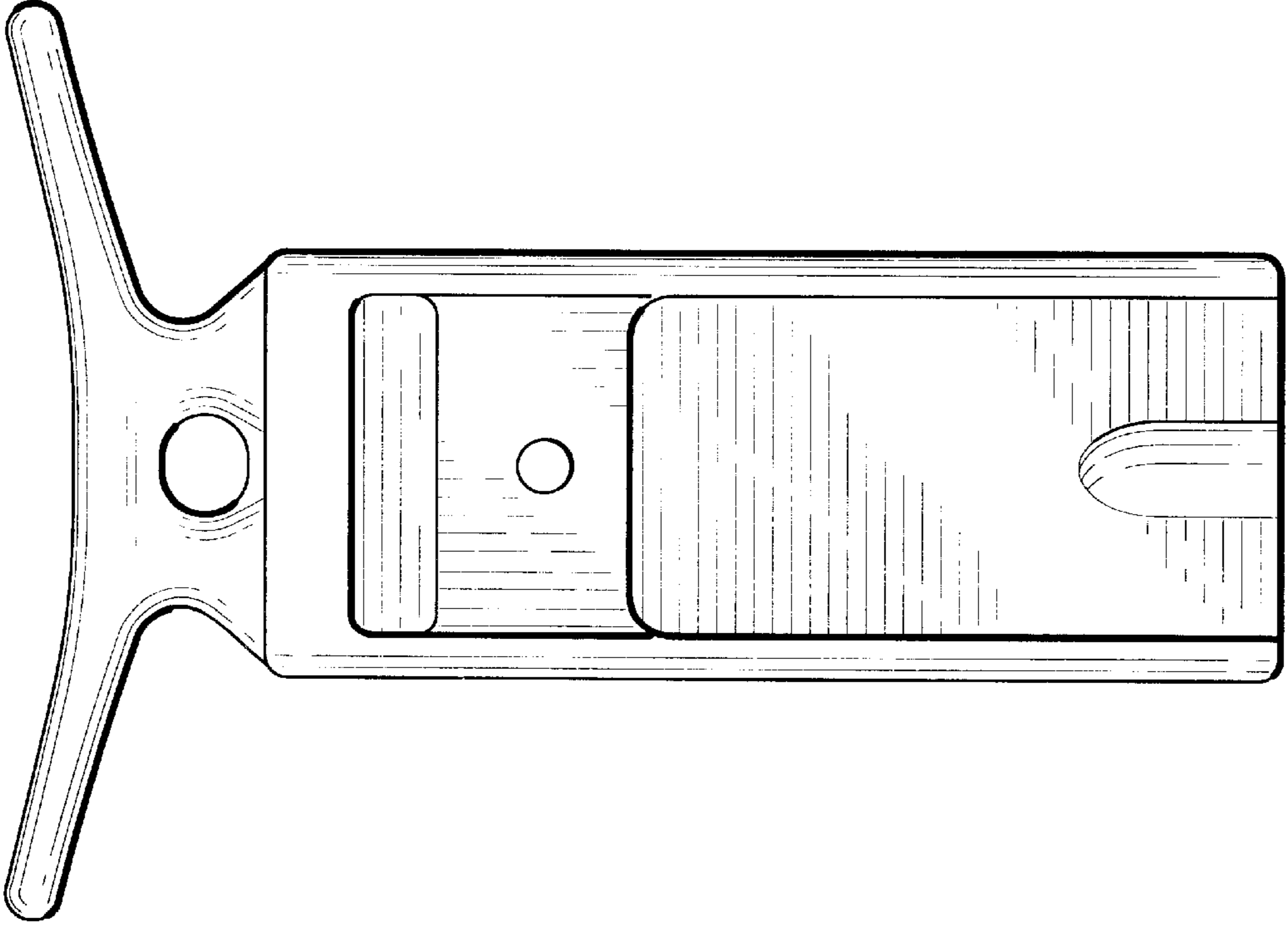

FIG. 1

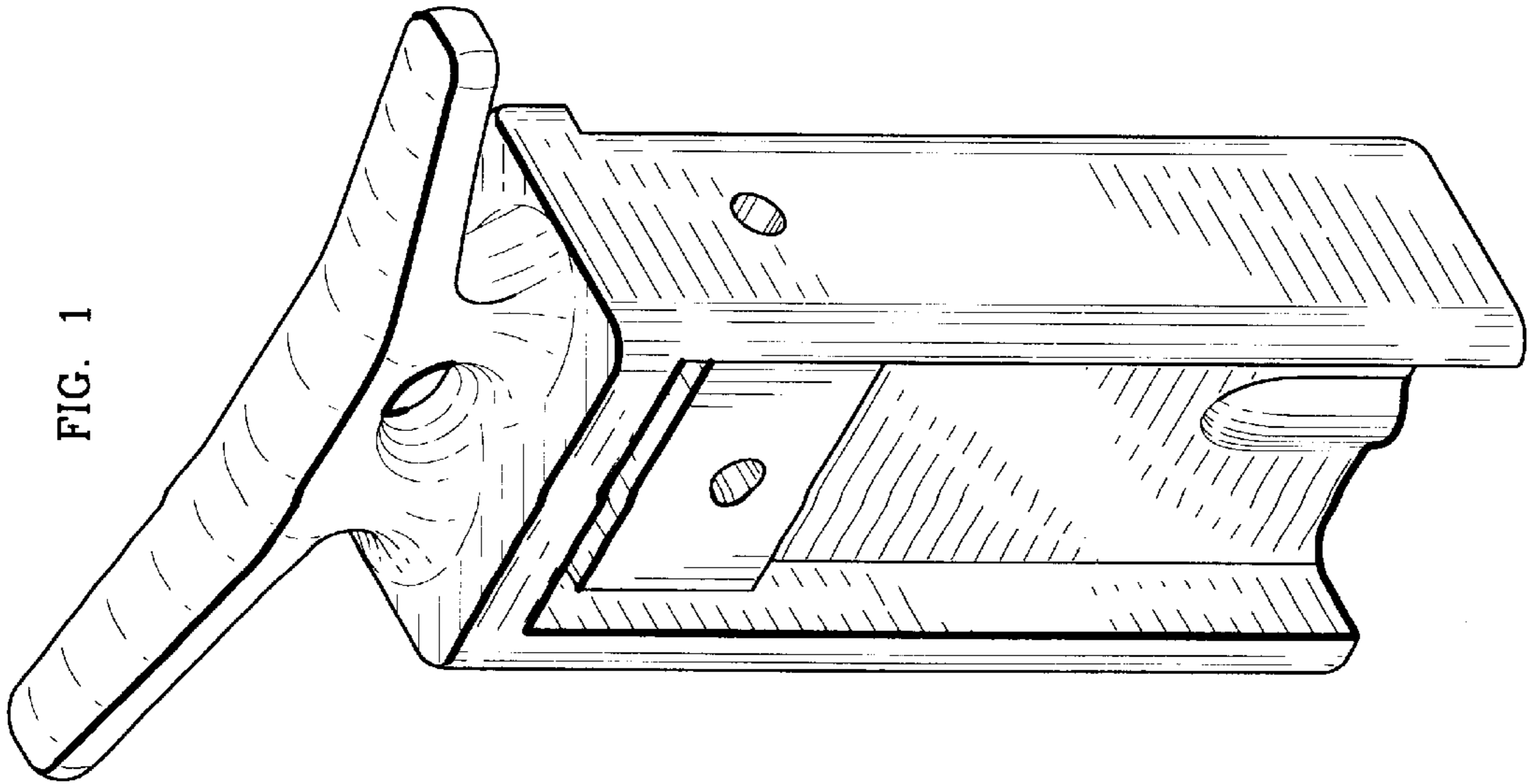

FIG. 4

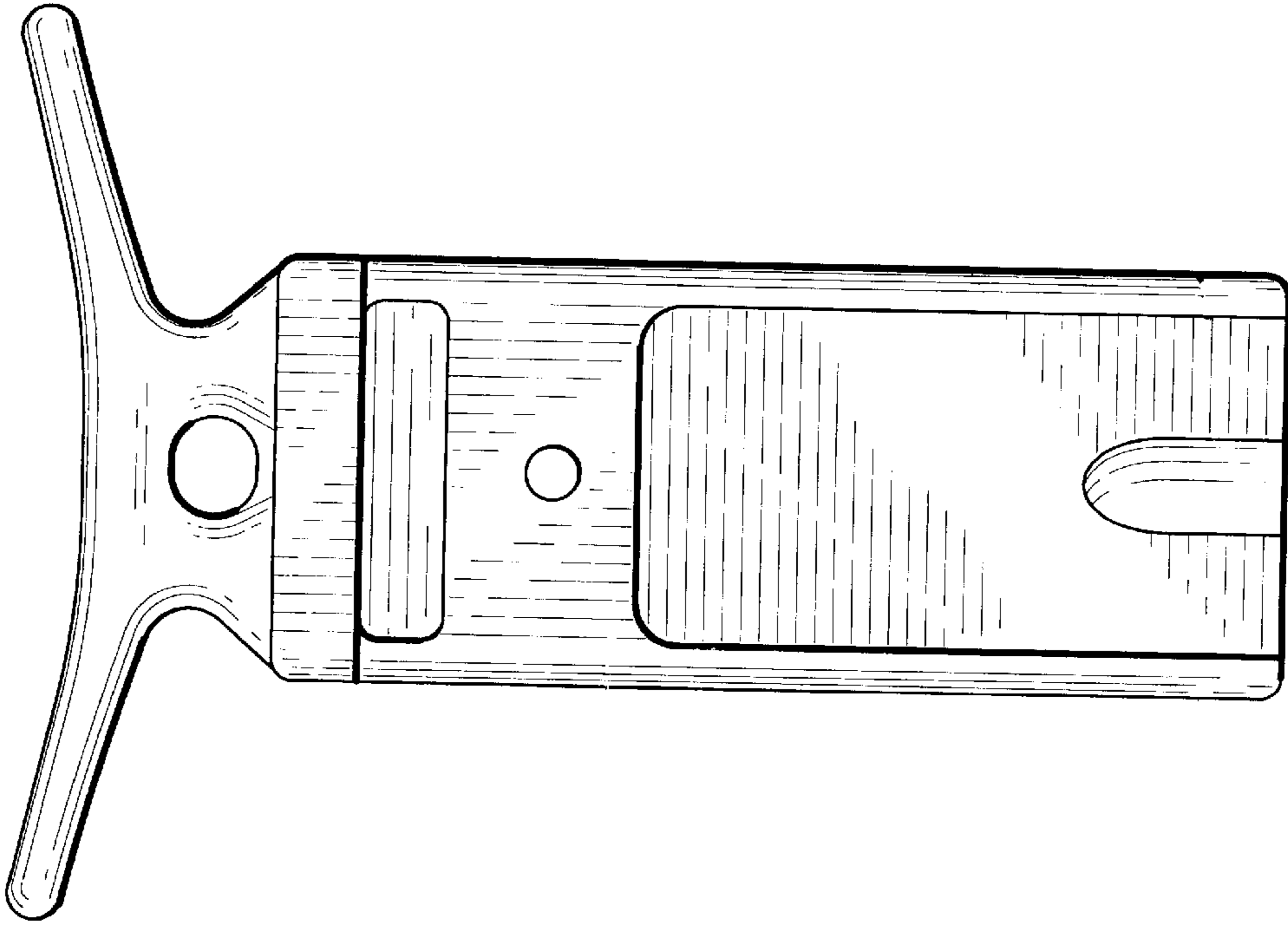

FIG. 5

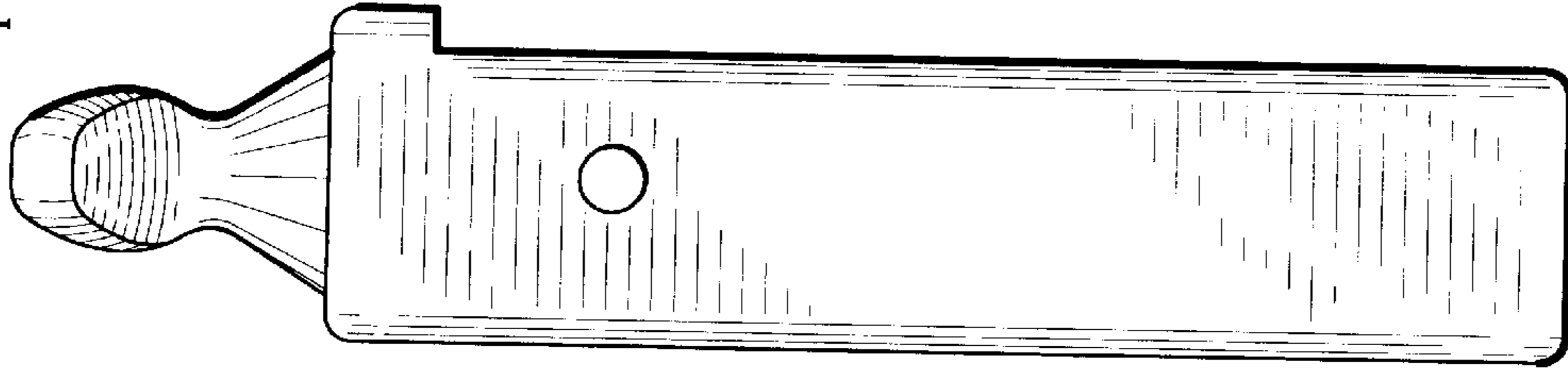

FIG. 6

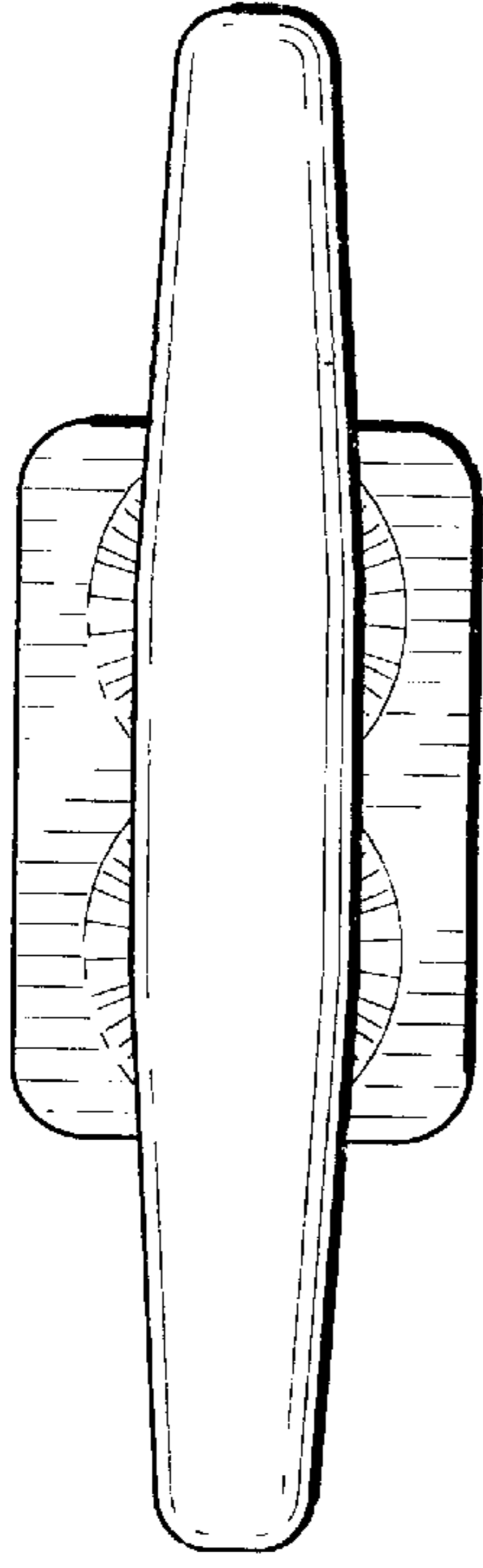

FIG. 7

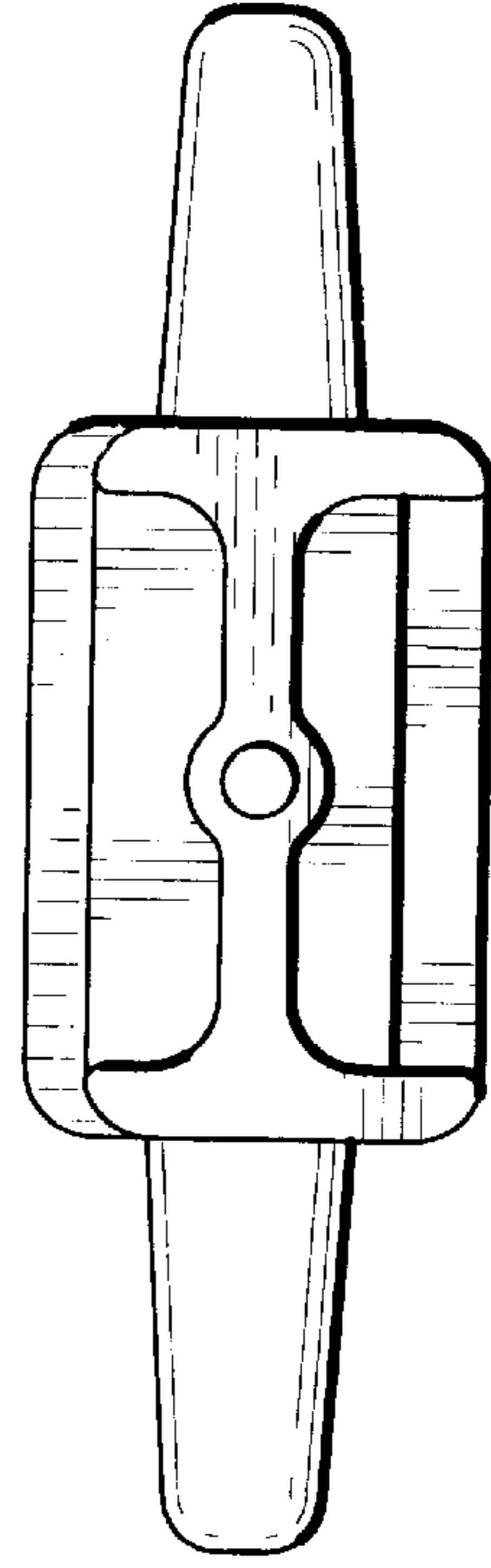

FIG. 10

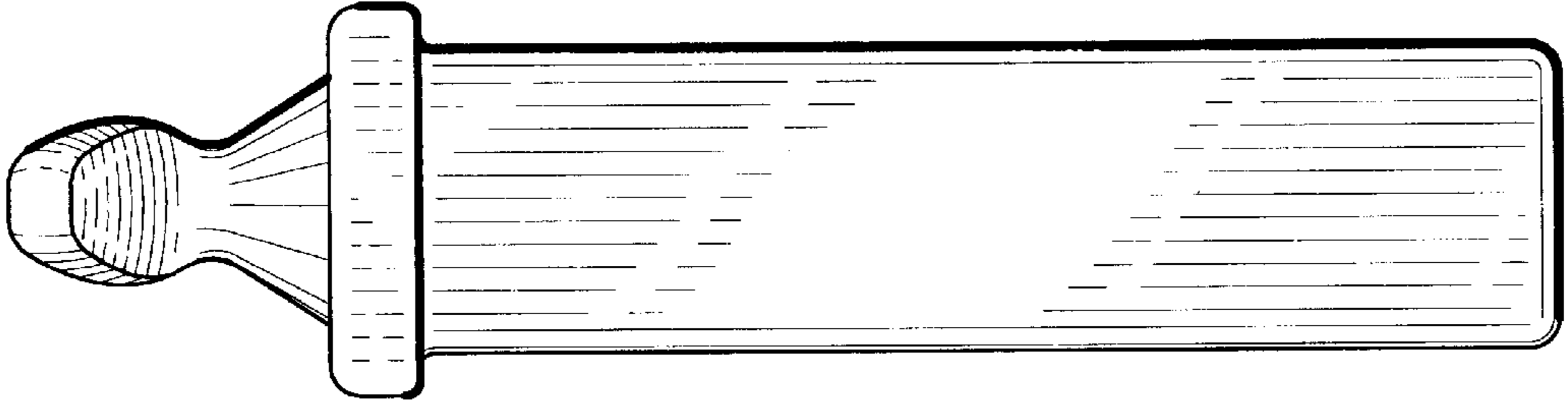

FIG. 9

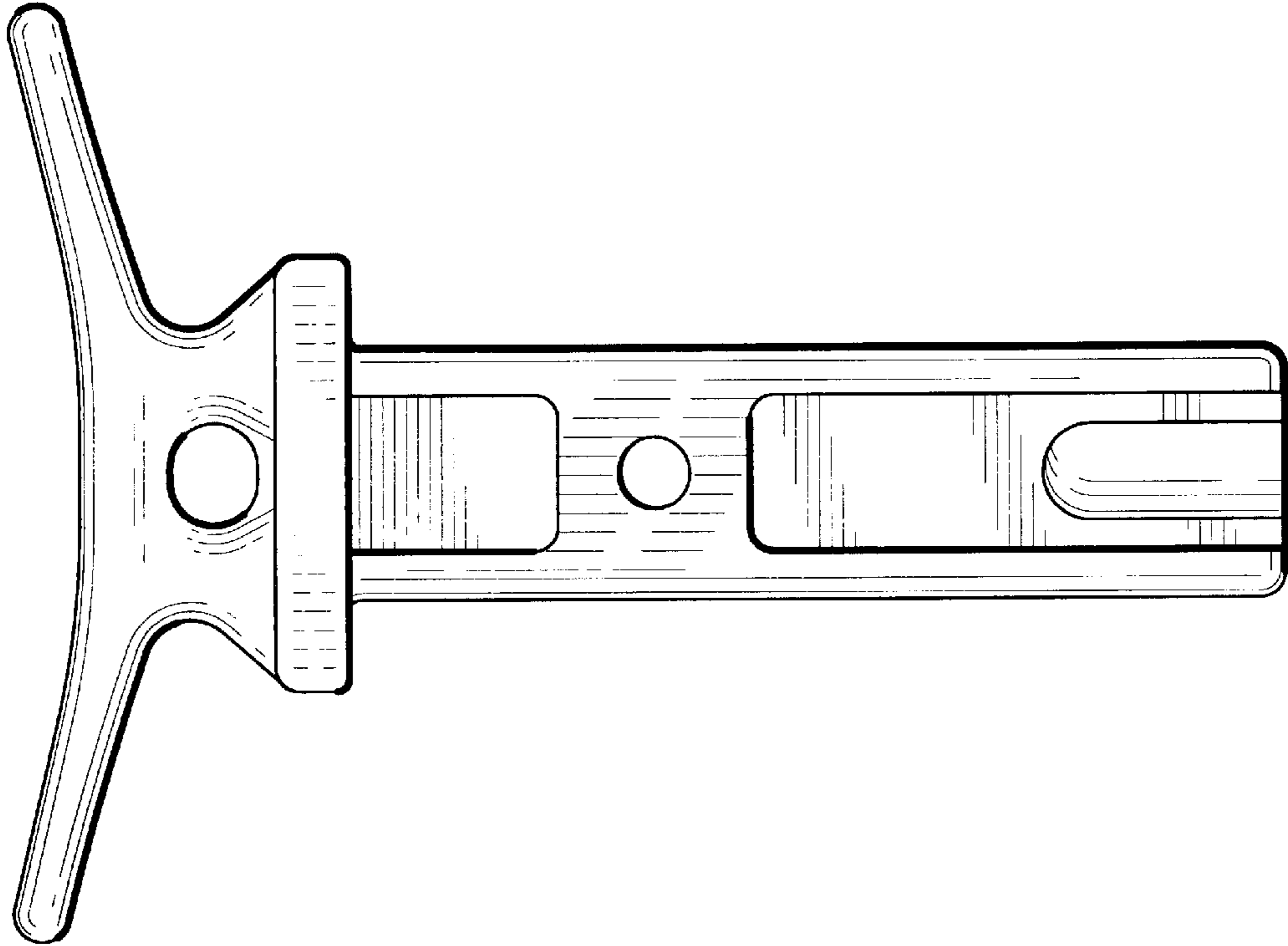

FIG. 8

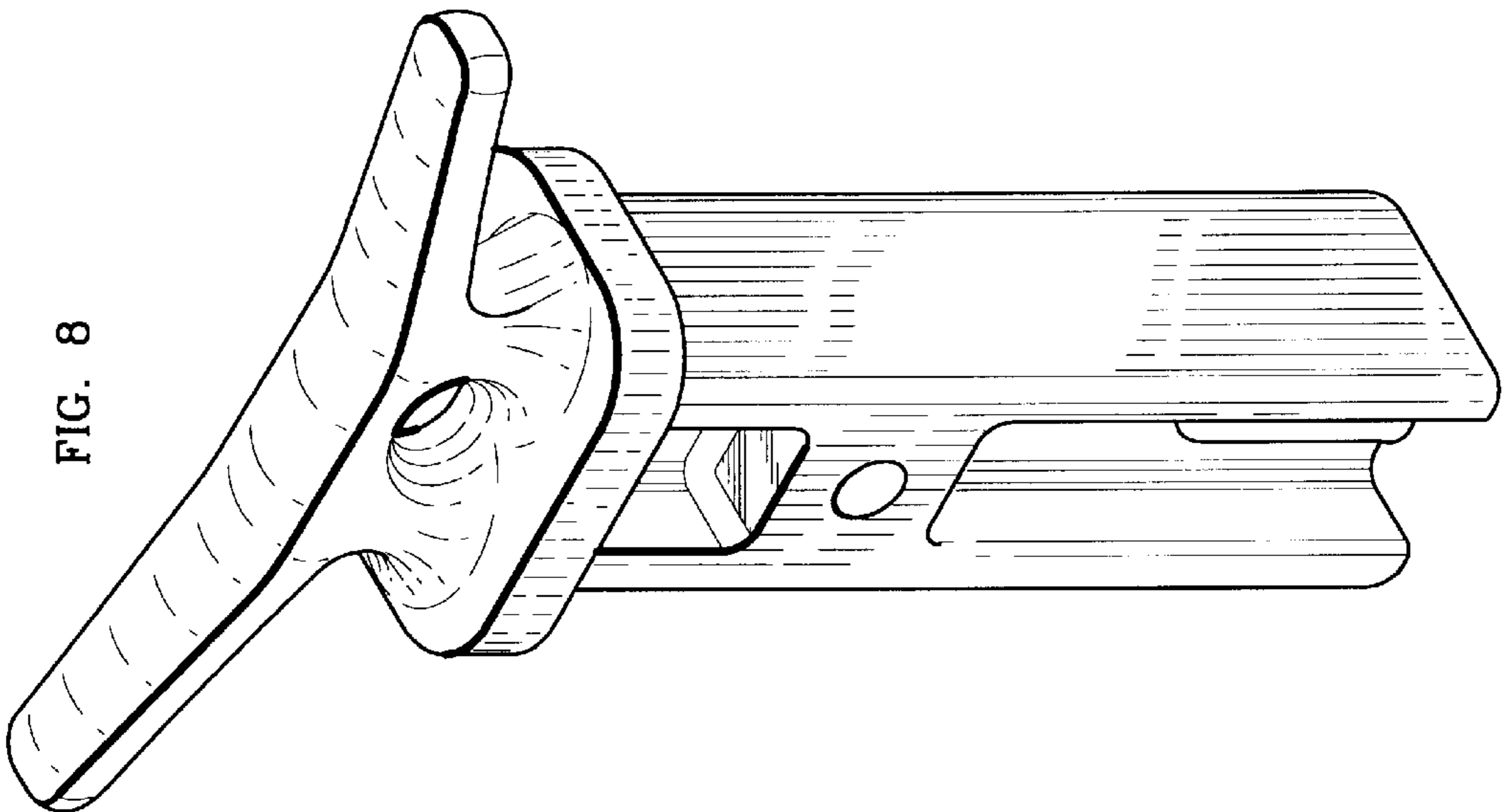

FIG. 11

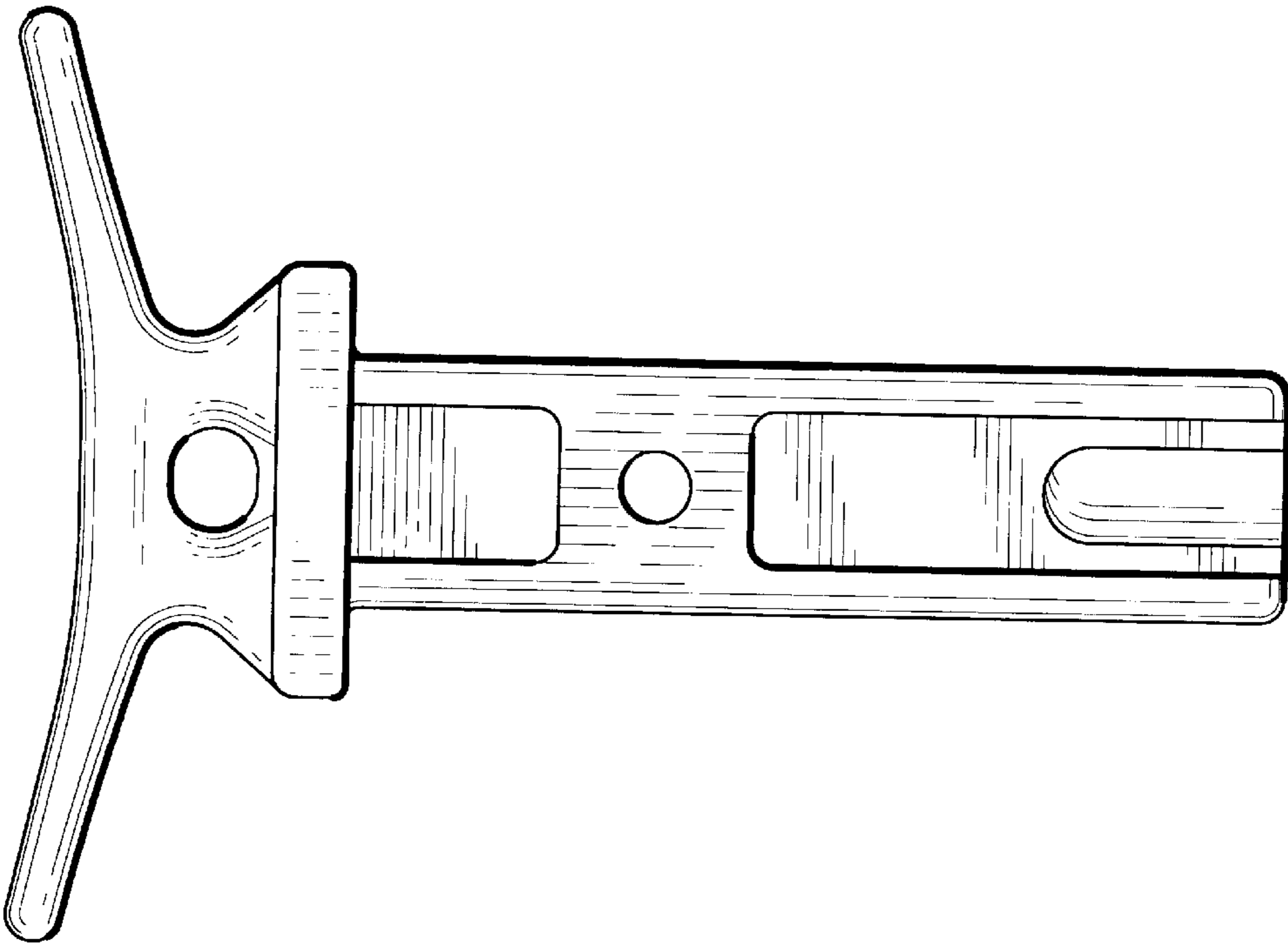

FIG. 12

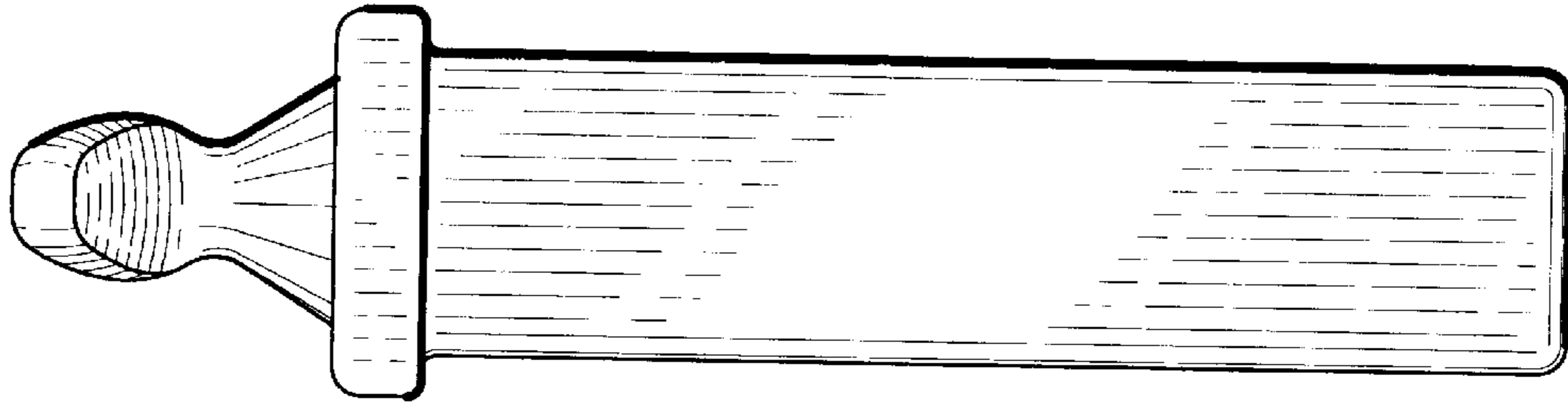

FIG. 13

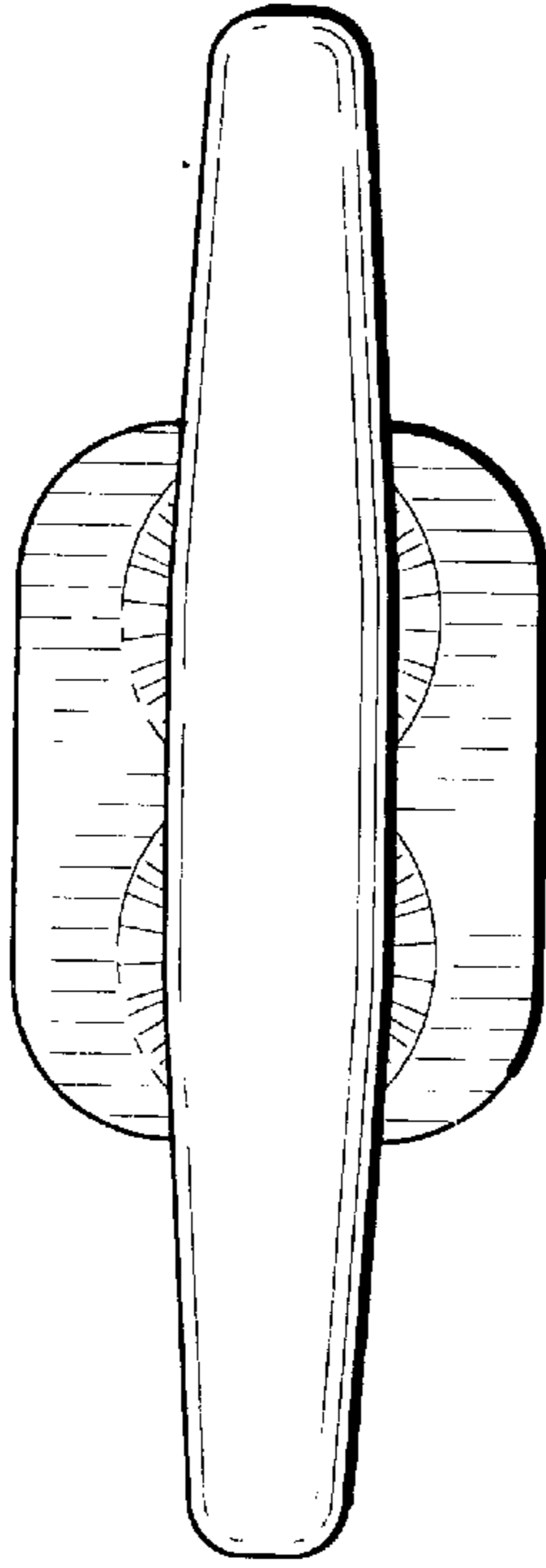

FIG. 14

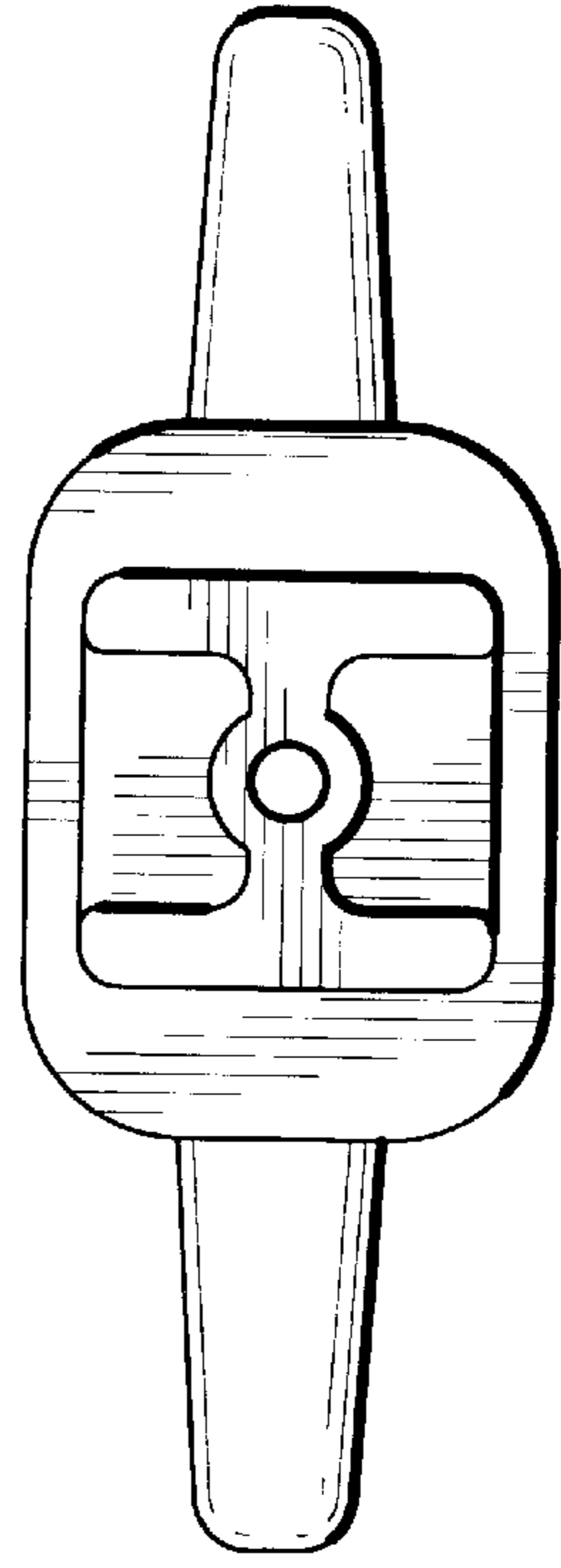

FIG. 17

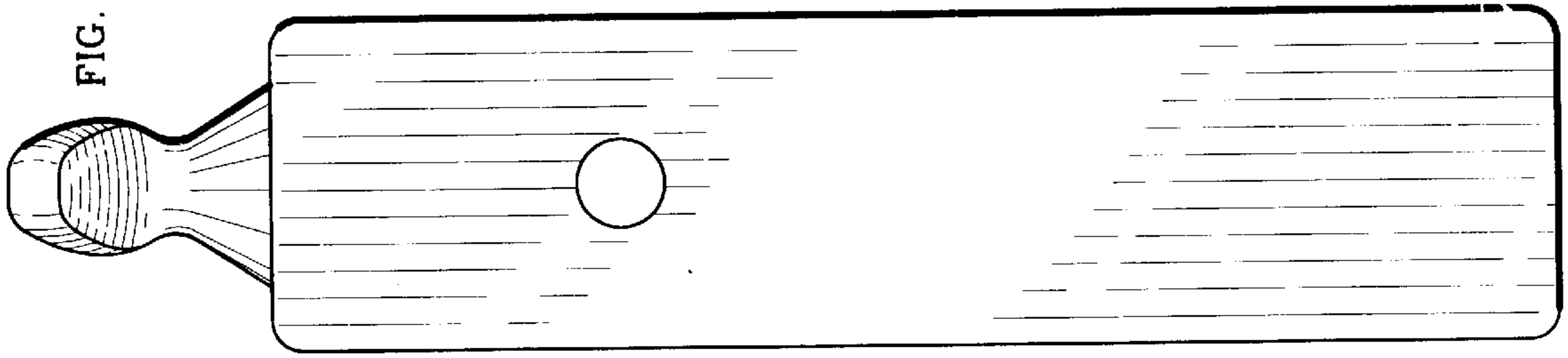

FIG. 16

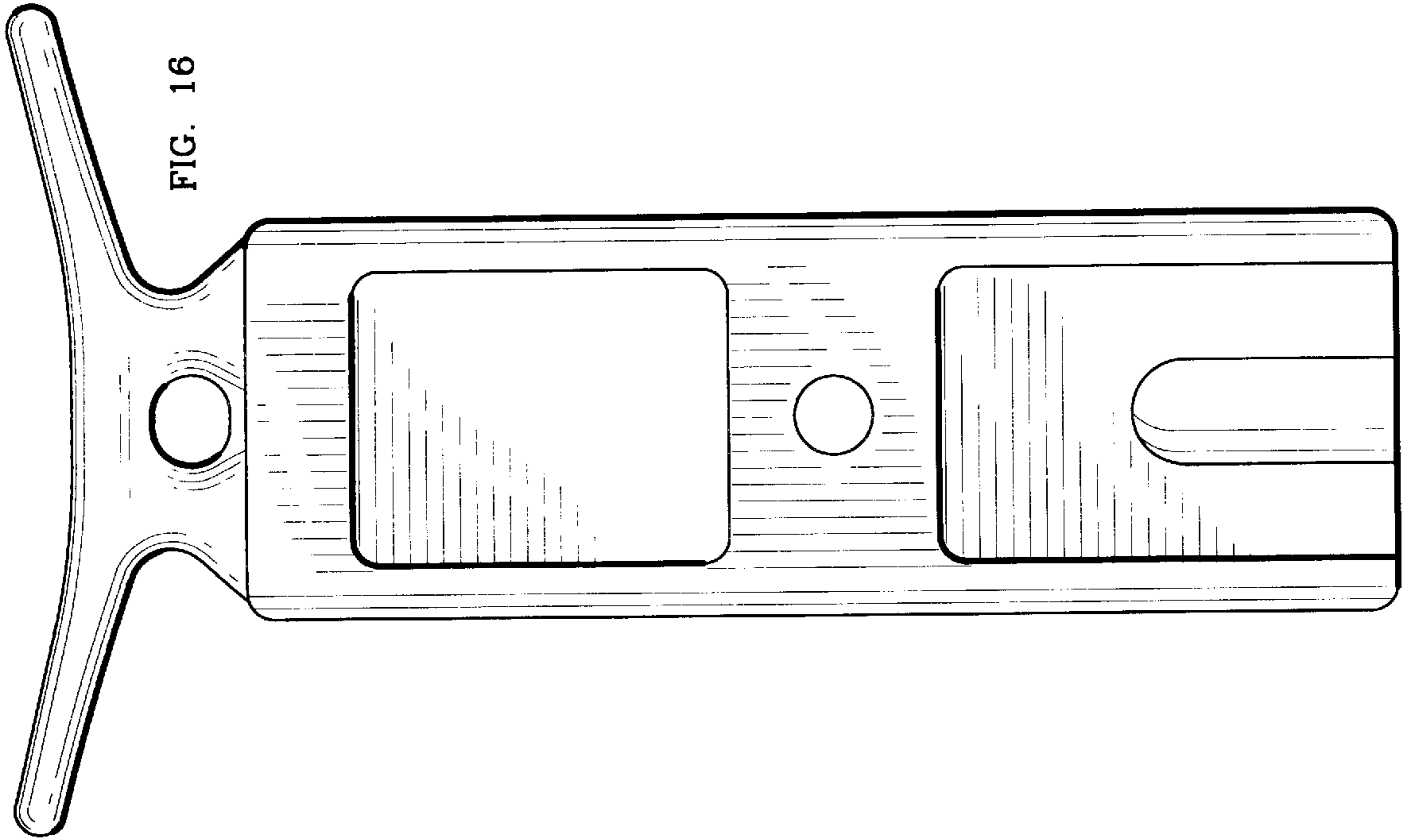
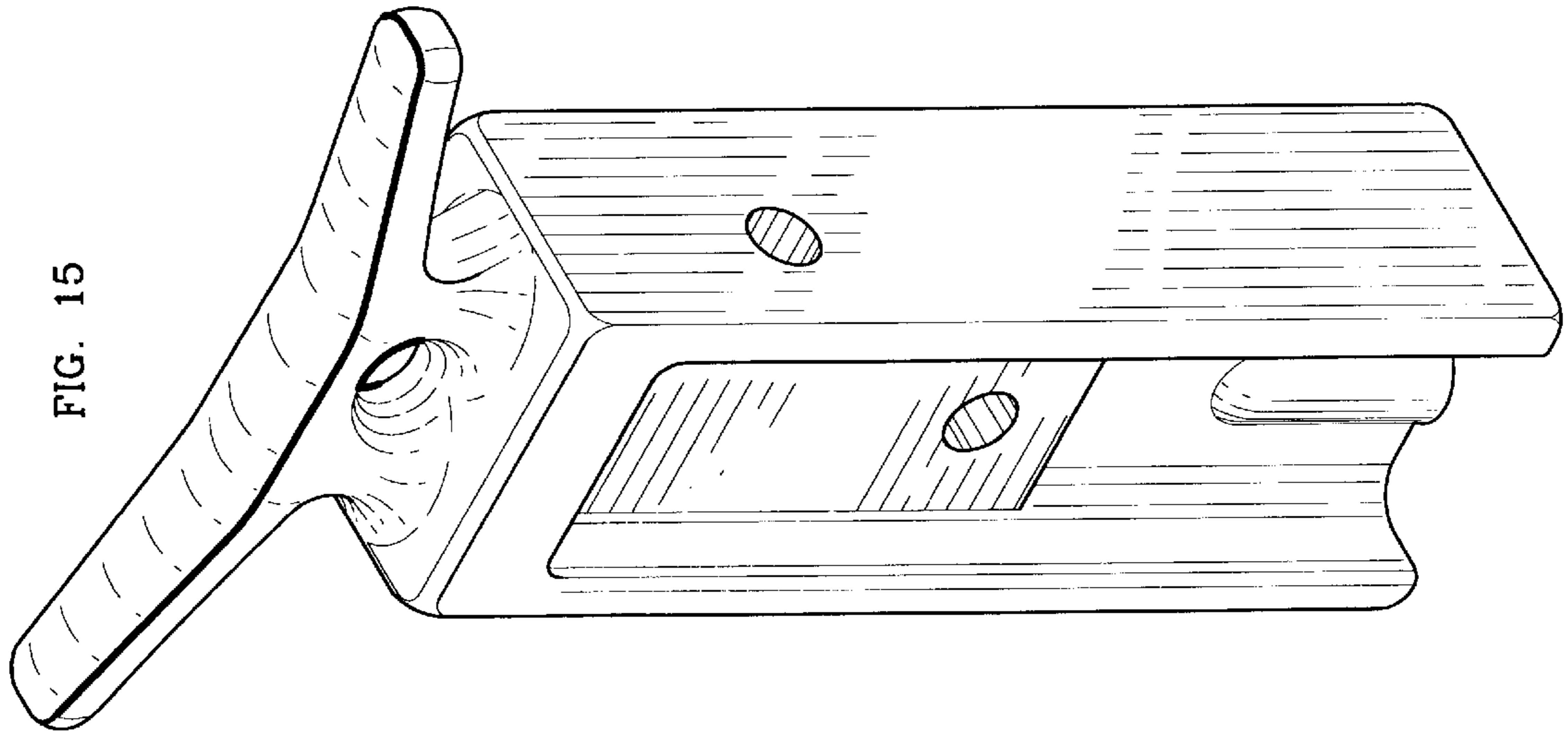

FIG. 15



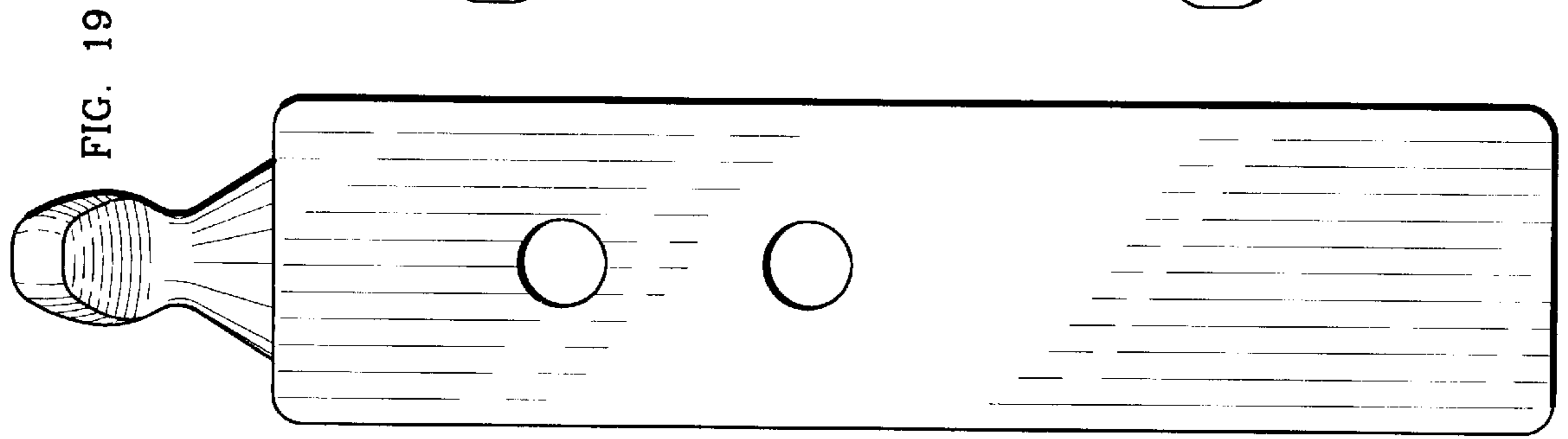

FIG. 18

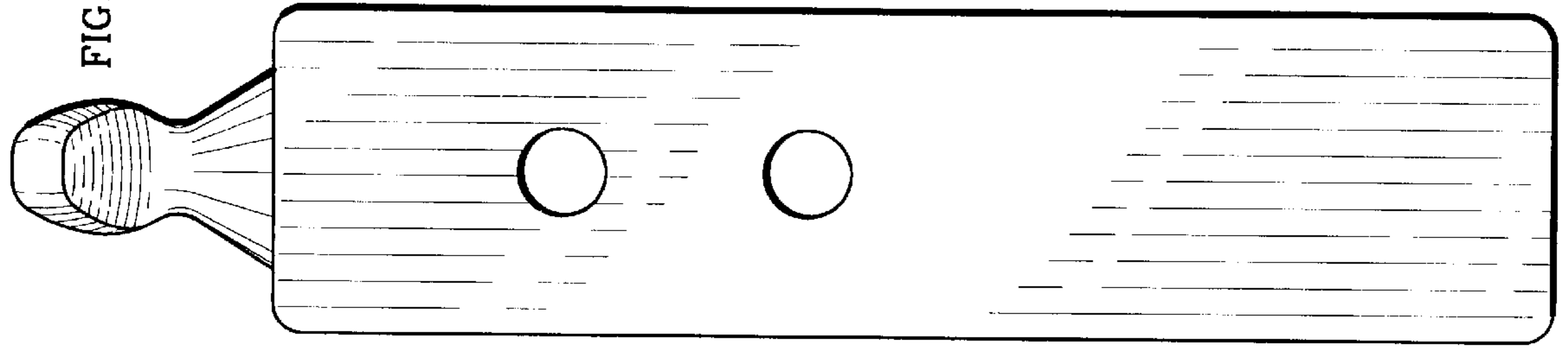

FIG. 19

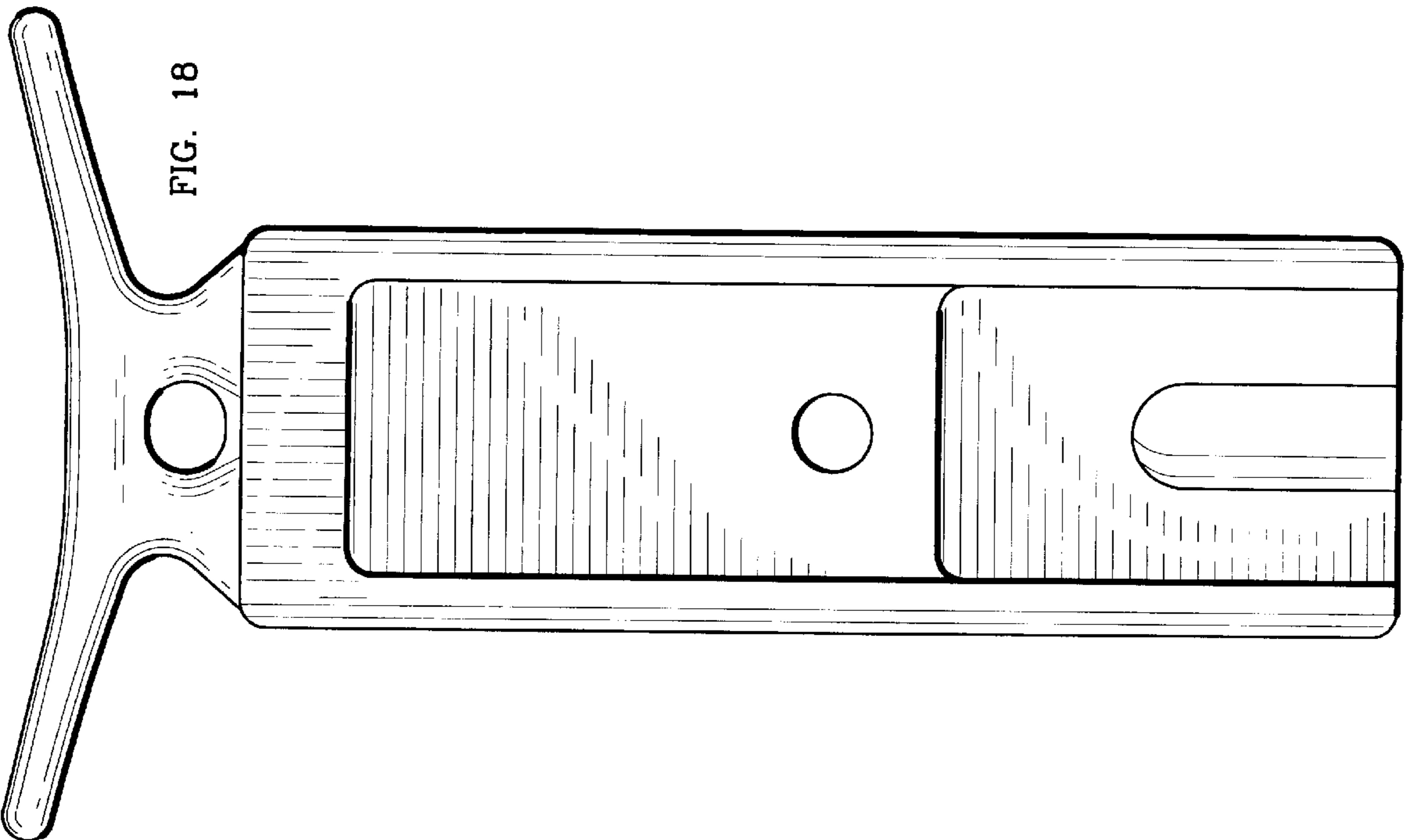

FIG. 20

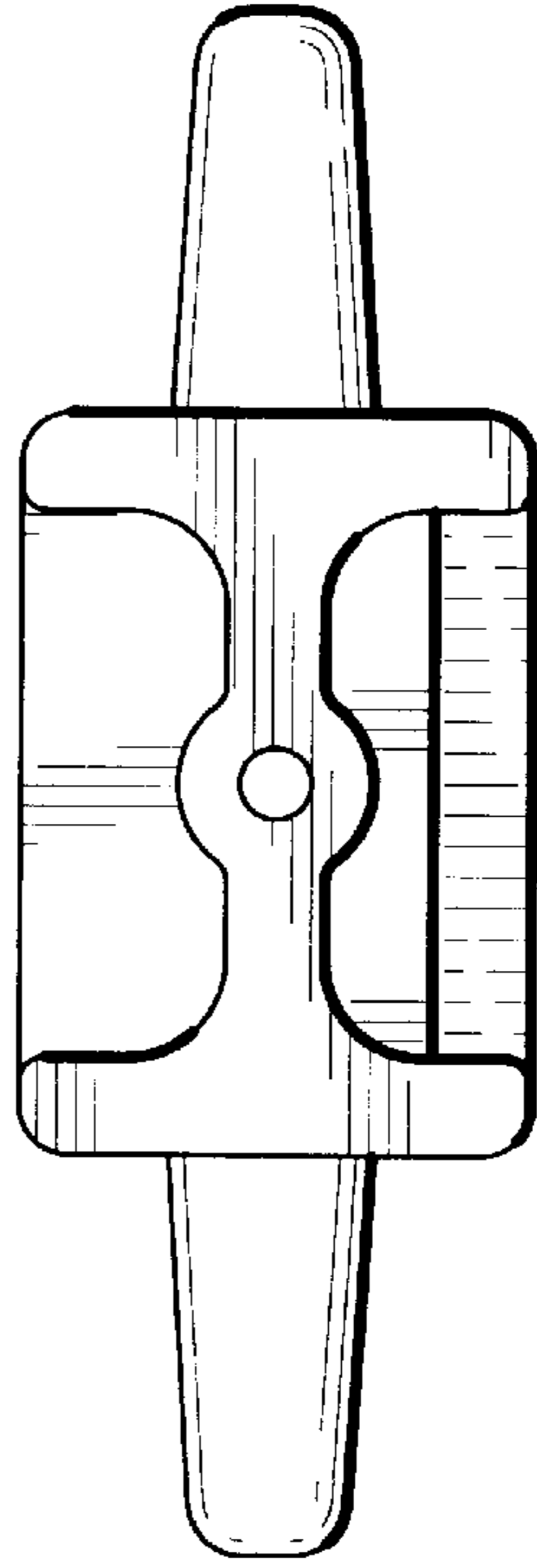
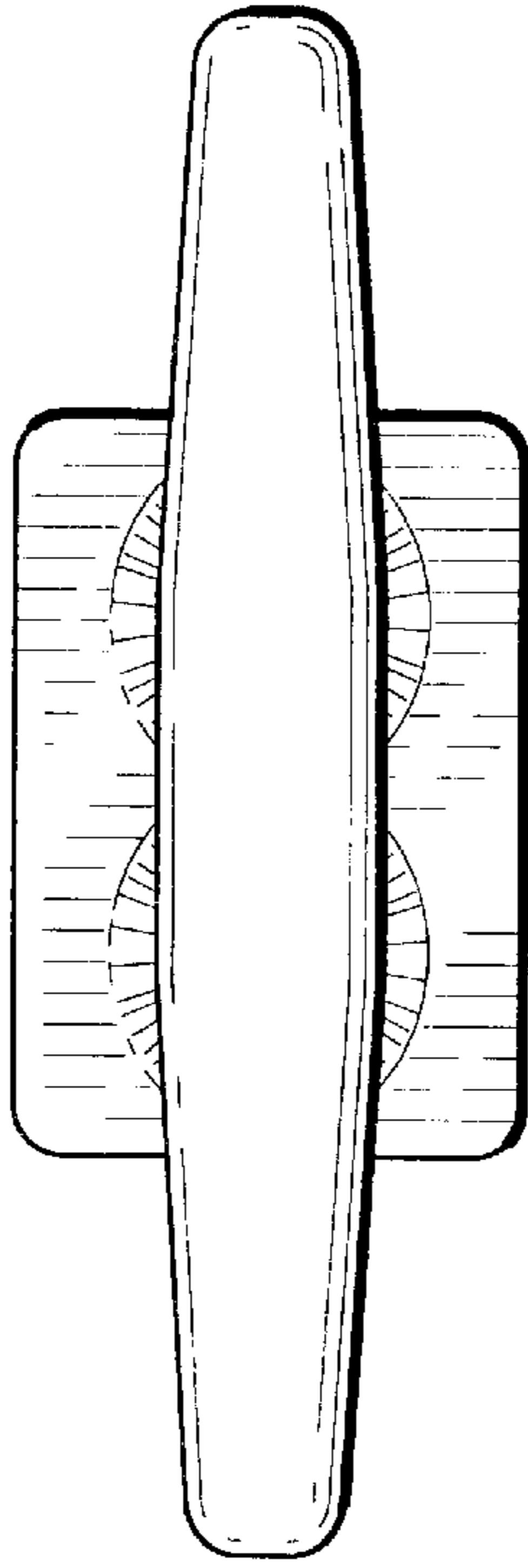

FIG. 21