



US00D406147S

United States Patent [19] Watanabe

[11] **Patent Number: Des. 406,147**

[45] **Date of Patent: **Feb. 23, 1999**

[54] **FOUR-STROKE CYCLE ENGINE**

D. 353,382 12/1994 Kiyooka et al. D15/1
D. 395,435 6/1998 Yoshida et al. D15/1

[75] Inventor: **Mitsunori Watanabe**, Shizuoka-ken, Japan

Primary Examiner—Ralf Seifert
Attorney, Agent, or Firm—Nikaido Marmelstein Murray & Oram LLP

[73] Assignee: **Fuji Robin Kabushiki Kaisha**, Shizuoka-ken, Japan

[**] Term: **14 Years**

[57] **CLAIM**

The ornamental design for a four-stroke cycle engine, as shown and described.

[21] Appl. No.: **85,489**

[22] Filed: **Mar. 24, 1998**

DESCRIPTION

[30] **Foreign Application Priority Data**

Sep. 24, 1997 [JP] Japan 9-068887

FIG. 1 is a perspective view from the front side of a four-stroke cycle engine showing my new design;
FIG. 2 is a perspective view from the rear side thereof;
FIG. 3 is a front elevational view thereof;
FIG. 4 is a rear elevational view thereof;
FIG. 5 is a top plan view thereof;
FIG. 6 is a bottom view thereof;
FIG. 7 is a left side elevational view thereof; and,
FIG. 8 is a right side elevational view thereof.

[51] **LOC (6) Cl.** **15-01**

[52] **U.S. Cl.** **D15/1**

[58] **Field of Search** D15/1, 3; 123/65 R, 123/52.1, 47 R, 61 R, 55.6, 41.7, 198 E

[56] **References Cited**

U.S. PATENT DOCUMENTS

D. 324,221 2/1992 Kiyooka et al. D15/1

1 Claim, 5 Drawing Sheets

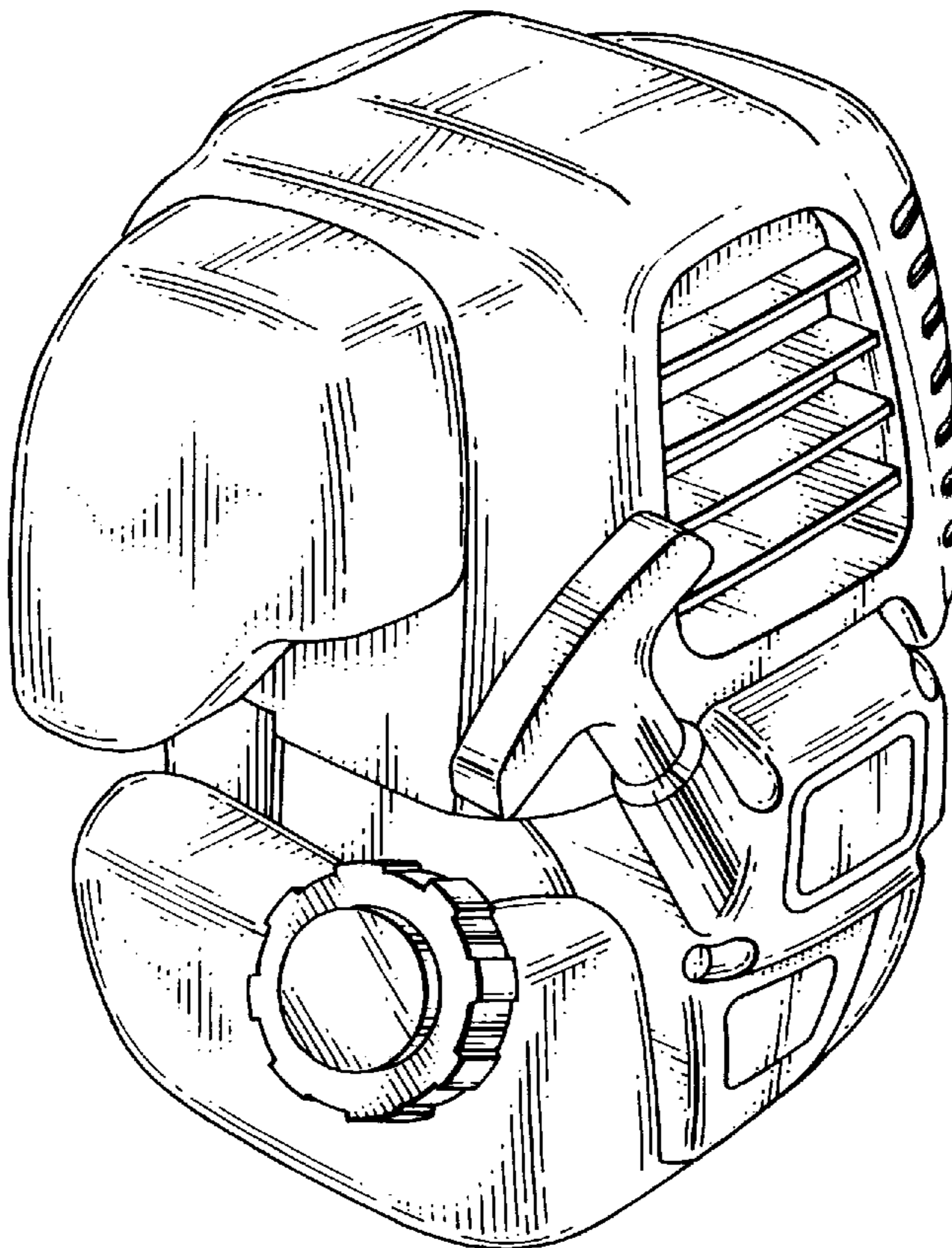

FIG. 1

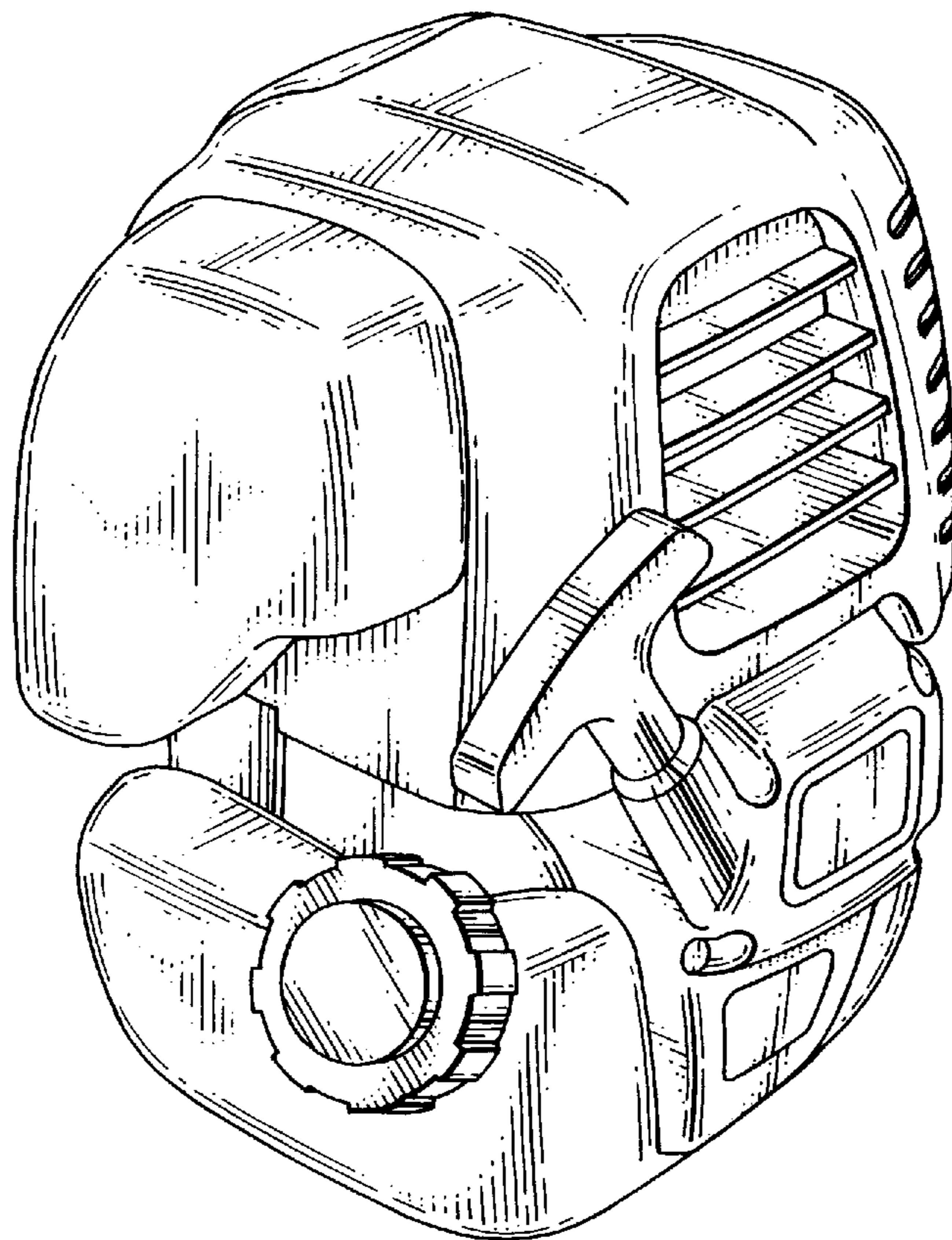

FIG. 2

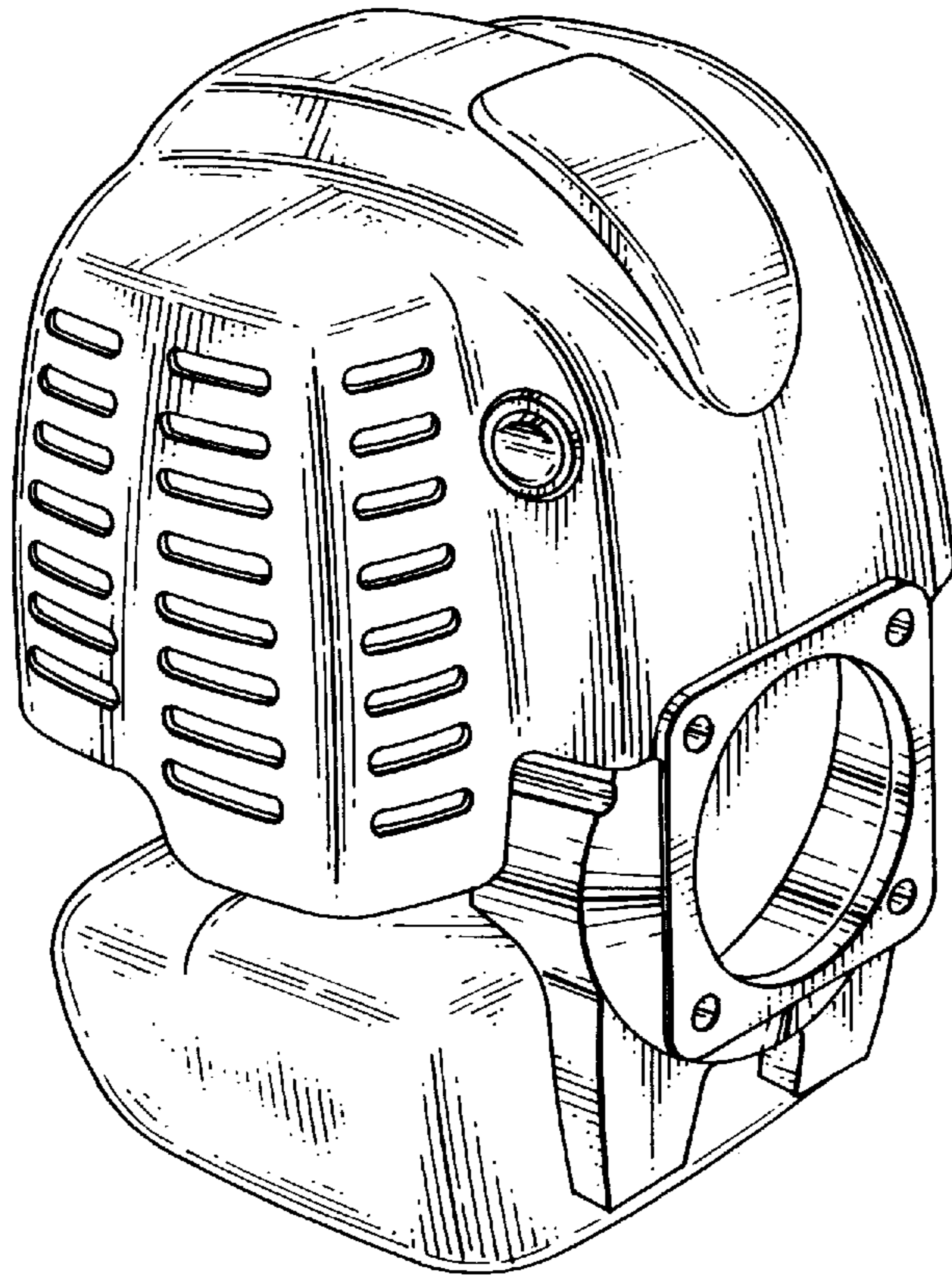

FIG. 3

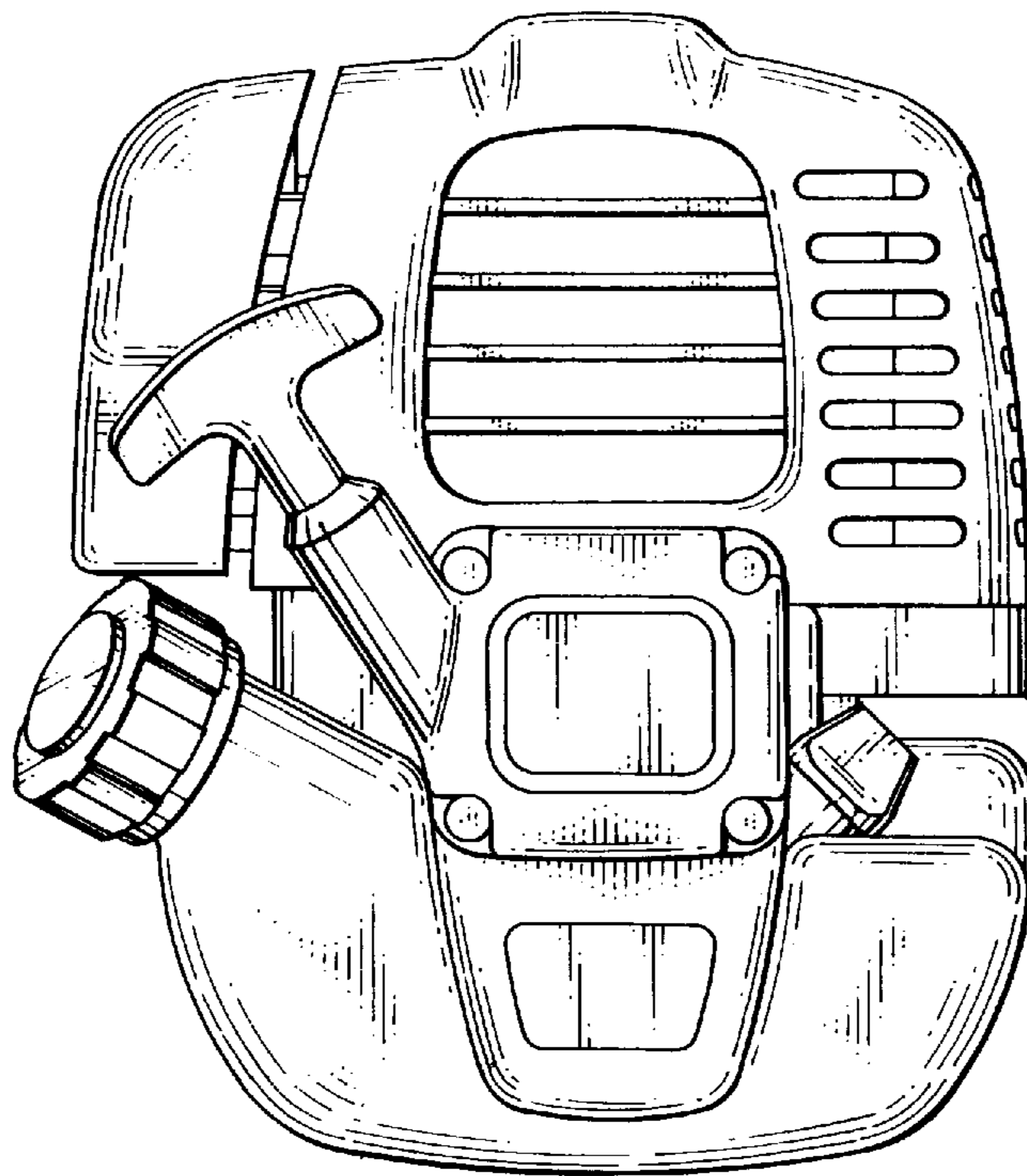

FIG. 4

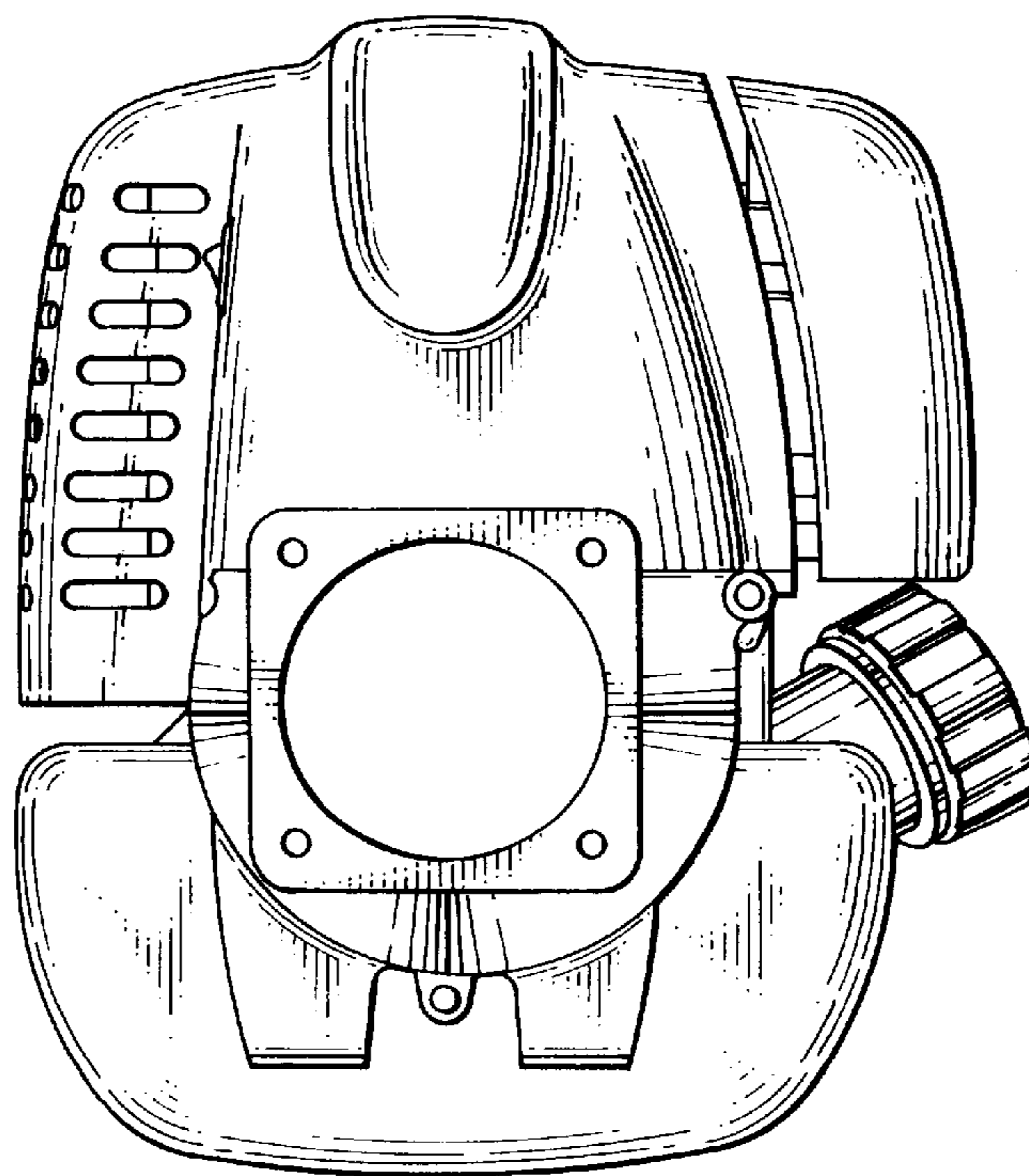

FIG. 5

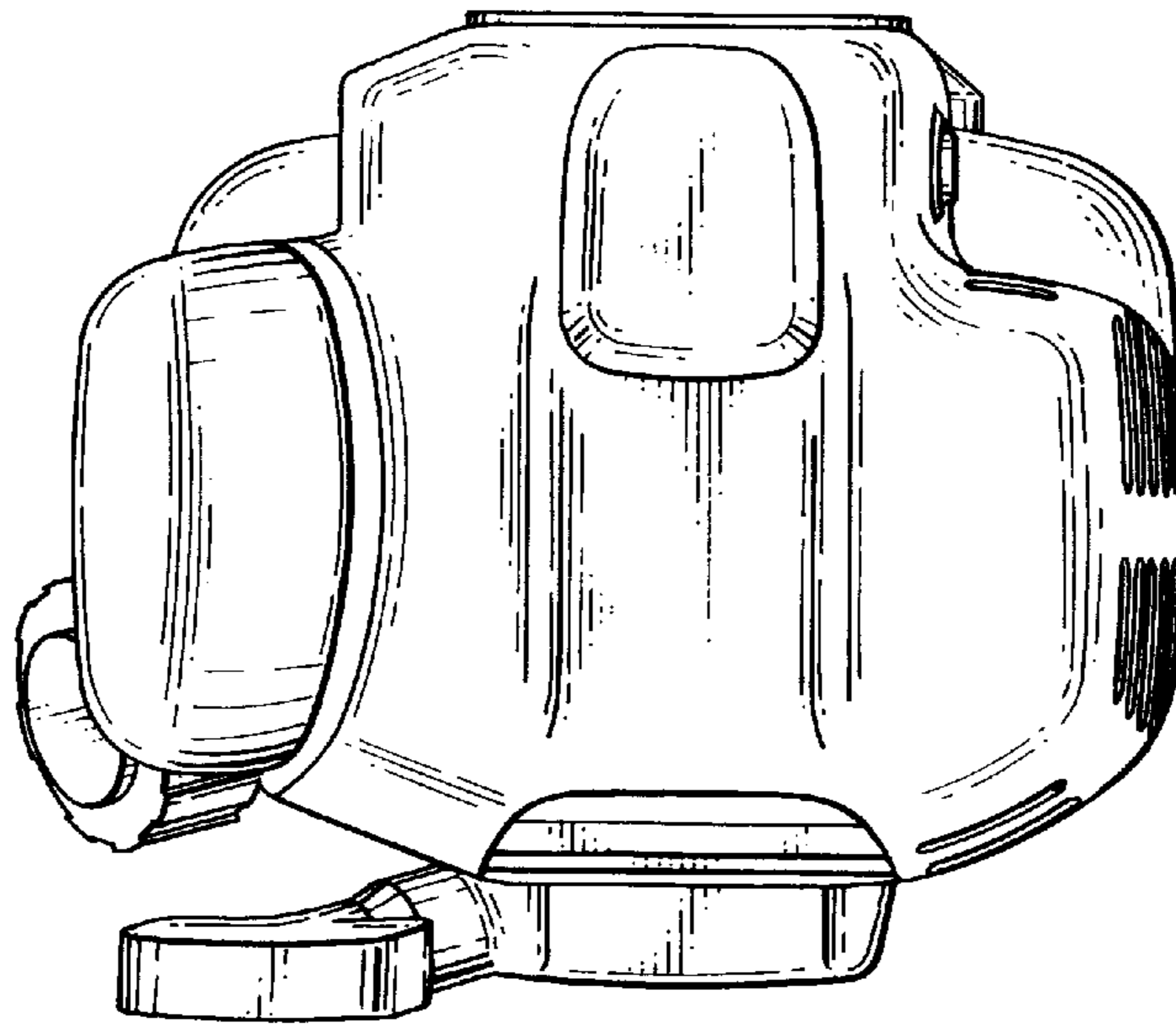

FIG. 6

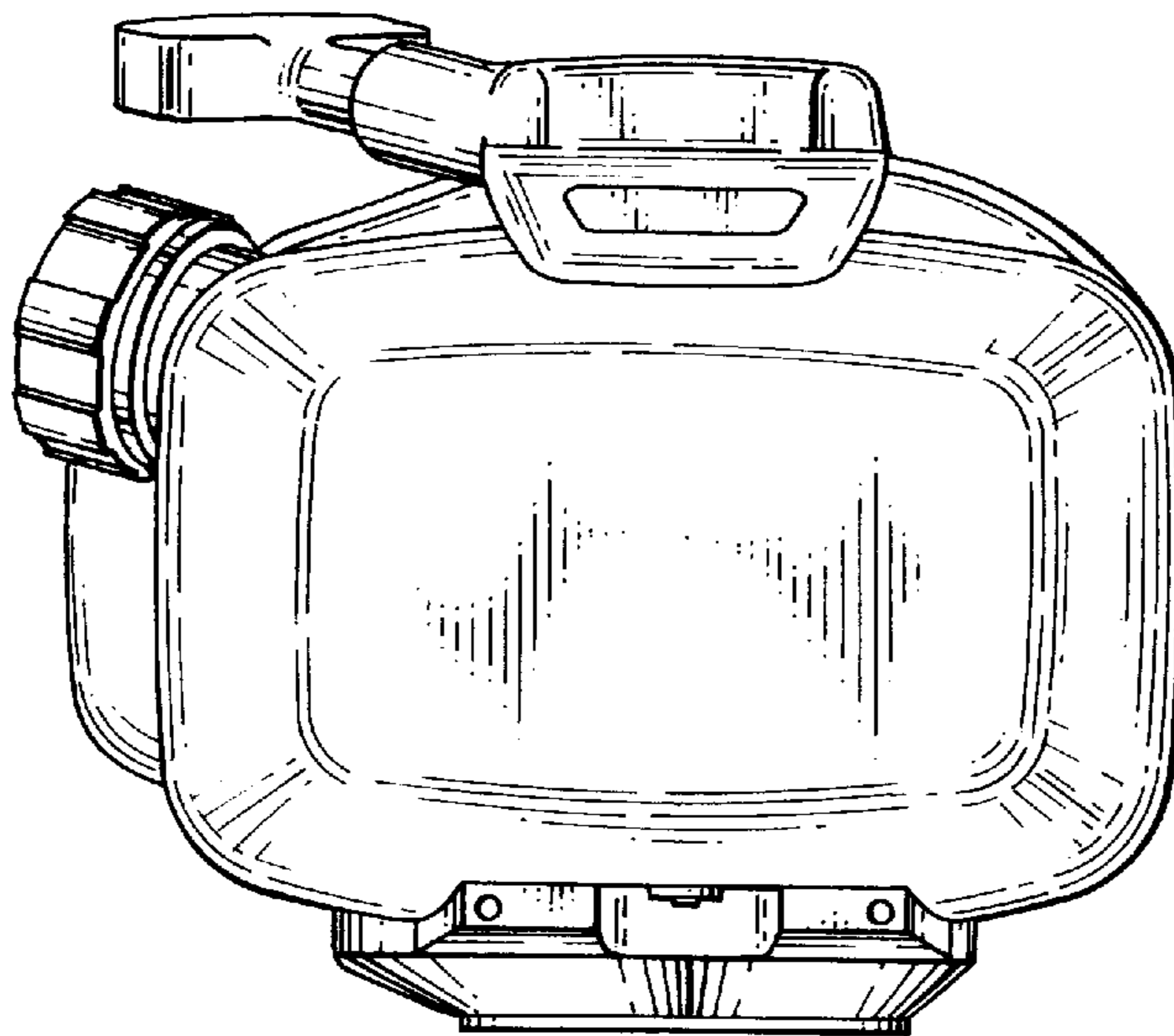

FIG. 7

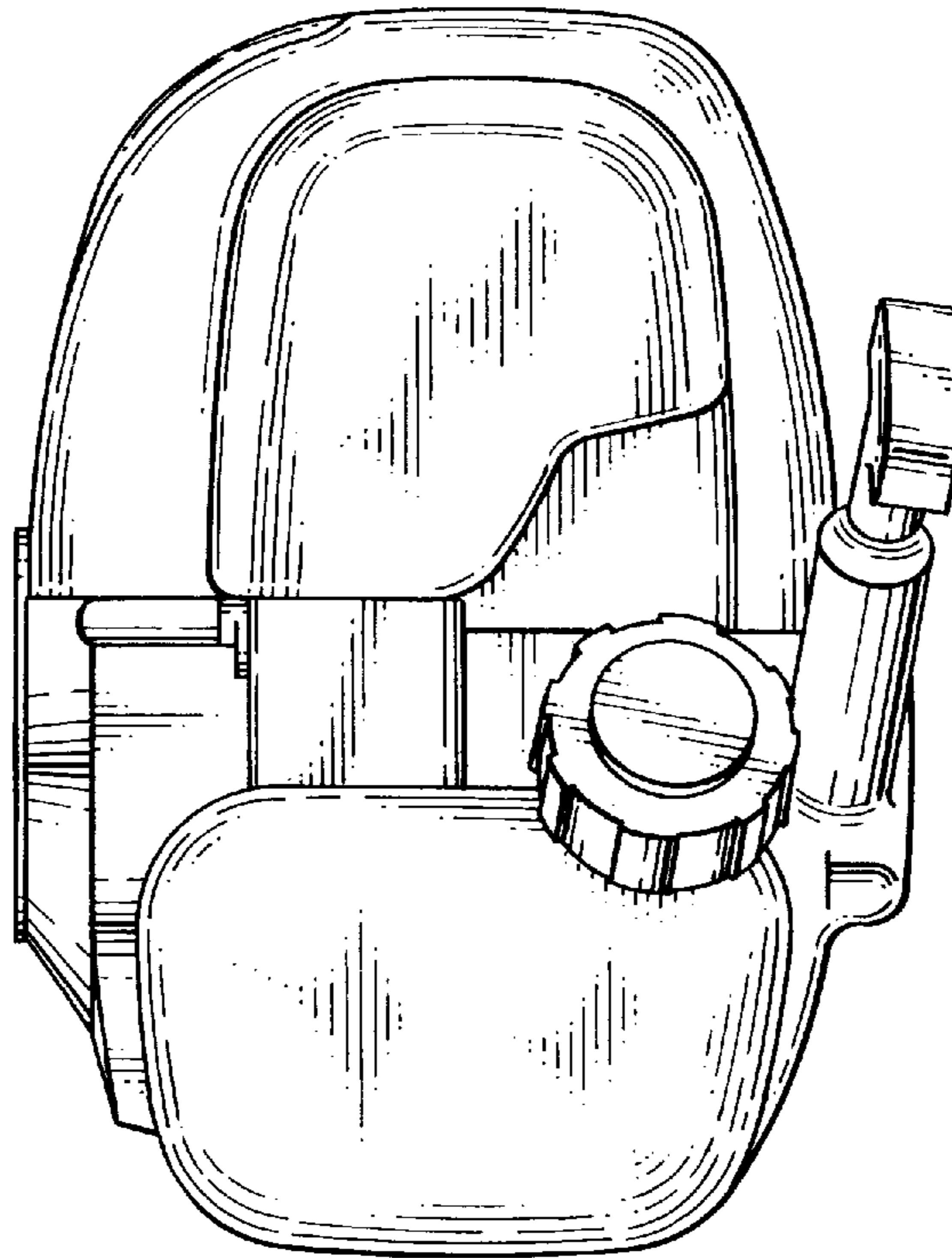

FIG. 8

