



US00D406029S

United States Patent [19]

Thomas et al.

[11] Patent Number: Des. 406,029

[45] Date of Patent: **Feb. 23, 1999

[54] WINDSHIELD REPAIR BRIDGE

[75] Inventors: Jonathan P. Thomas, Maple Lake;
Mark Charles Christian, St. Louis
Park, both of Minn.

[73] Assignee: TCG International Inc., Burnaby,
Canada

[**] Term: 14 Years

[21] Appl. No.: 77,295

[22] Filed: Oct. 1, 1997

4,775,305 10/1988 Alexander et al. .
4,814,185 3/1989 Jones .
4,820,148 4/1989 Anderson .
4,919,602 4/1990 Janszen 425/12
4,921,411 5/1990 Ottenheimer .
4,954,300 9/1990 Dotson .
4,995,798 2/1991 Ameter .
5,069,836 12/1991 Werner et al. .
5,104,304 4/1992 Dotson .
5,122,042 6/1992 Elniger .
5,234,325 8/1993 Hill .
5,425,827 6/1995 Campfield .
5,429,692 7/1995 Campfield .
5,565,217 10/1996 Beckert et al. .
B1 5,116,441 11/1993 Campfield .

Related U.S. Application Data

[63] Continuation-in-part of Ser. No. 60,628, Oct. 2, 1996.

[51] LOC (6) Cl. 08-05

[52] U.S. Cl. D8/51

[58] Field of Search D8/51; 29/402.18;
65/28; 156/94, 382, 73.6; 264/36; 269/1,
75

OTHER PUBLICATIONS

Liquid Resins International, Ltd. Catalog, 21 pages, dated Apr. 1, 1992.

The Glass Mechanix® brochure entitled "A Chair Path to Your Future Success," 8 pages, undated.

Wood's POWR-Grip Co., Inc. Brochure entitled "Vacuum Cups For Materials Handling," 4 pages, date Jan., 1995.

Primary Examiner—Freda Nunn
Attorney, Agent, or Firm—Merchant, Gould, Smith, Edell, Welter & Schmidt, P.A.

[56] References Cited

U.S. PATENT DOCUMENTS

3,562,366 2/1971 Sohl .
3,765,975 10/1973 Hollingsworth .
3,988,400 10/1976 Luhman, III .
3,993,520 11/1976 Werner et al. .
4,032,272 6/1977 Miller .
4,047,863 9/1977 McCluskey et al. .
4,132,516 1/1979 Story .
4,200,478 4/1980 Jacino et al. .
4,231,494 11/1980 Greenwood .
4,249,868 2/1981 Petersen .
4,280,861 7/1981 Schwartz .
4,291,866 9/1981 Petersen .
4,385,015 5/1983 Klettke .
4,385,879 5/1983 Wilkinson .
4,419,305 12/1983 Matles .
4,569,808 2/1986 Smali .
4,597,727 7/1986 Birkhauser, III .
4,622,085 11/1986 Yamada et al. .
4,681,520 7/1987 Birkhauser, III .
4,744,841 5/1988 Thomas .

[57] CLAIM

The ornamental design for a windshield repair bridge, as shown and described.

DESCRIPTION

FIG. 1 is a perspective view of a windshield repair bridge showing our new design;
FIG. 2 is a front end elevational view thereof;
FIG. 3 is a rear end elevational view thereof;
FIG. 4 is a top plan view thereof;
FIG. 5 is a bottom plan view thereof; and,
FIG. 6 is a side elevational view thereof, an opposite side being identical thereto.
The broken lines are shown in FIG. 1 for illustrative purposes only and form no part of the claimed design.

1 Claim, 5 Drawing Sheets

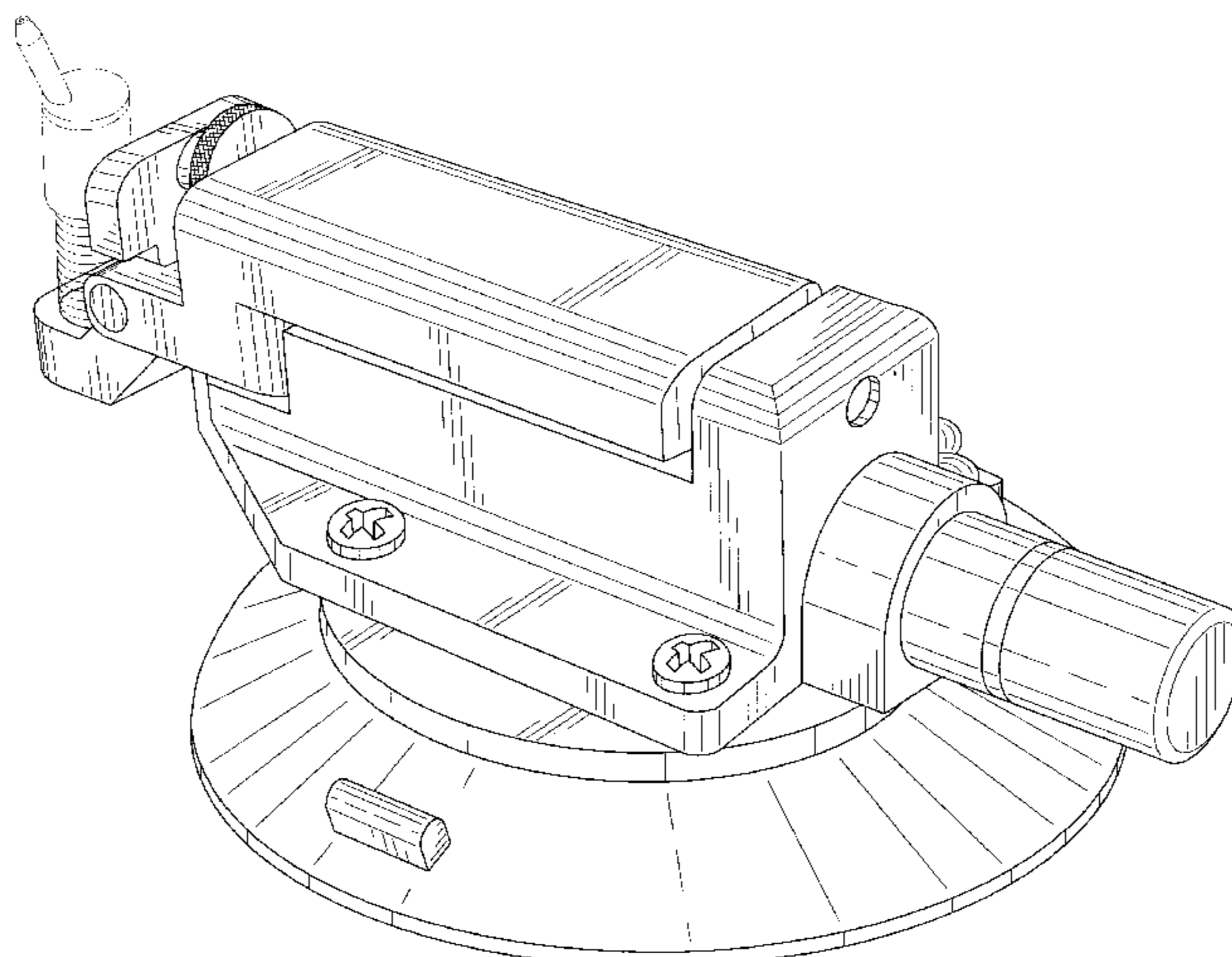

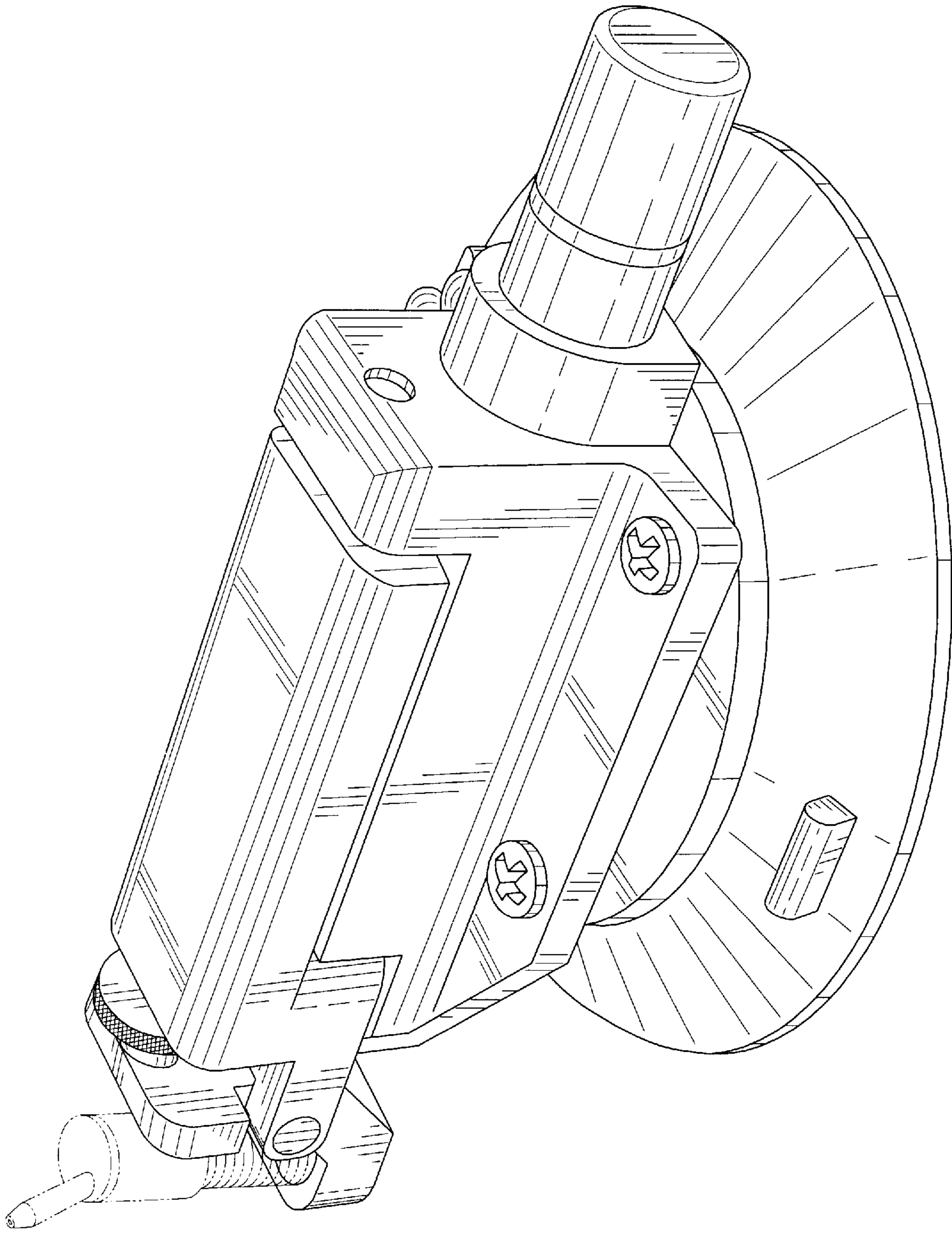

FIG. 1

FIG. 2

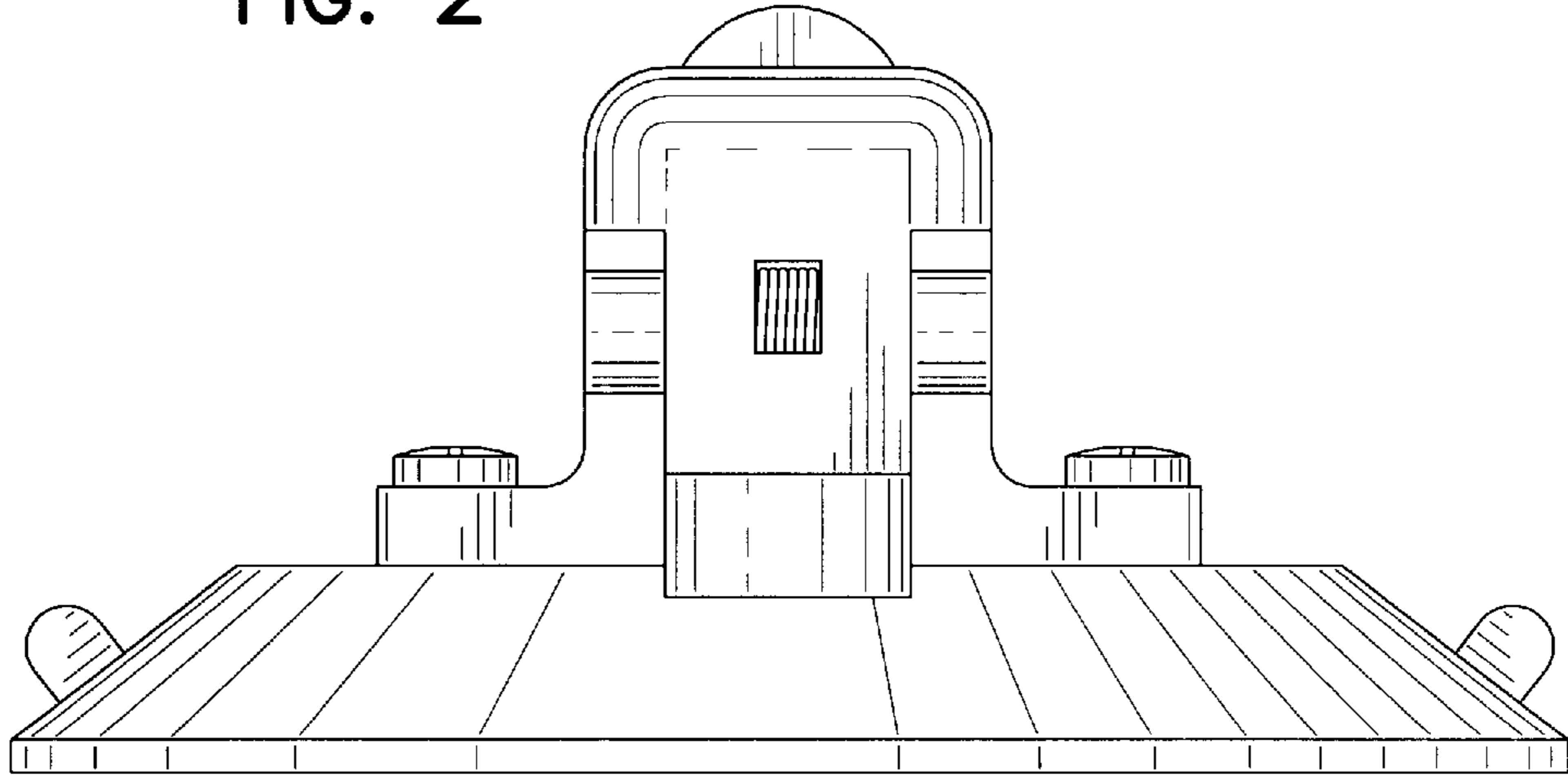
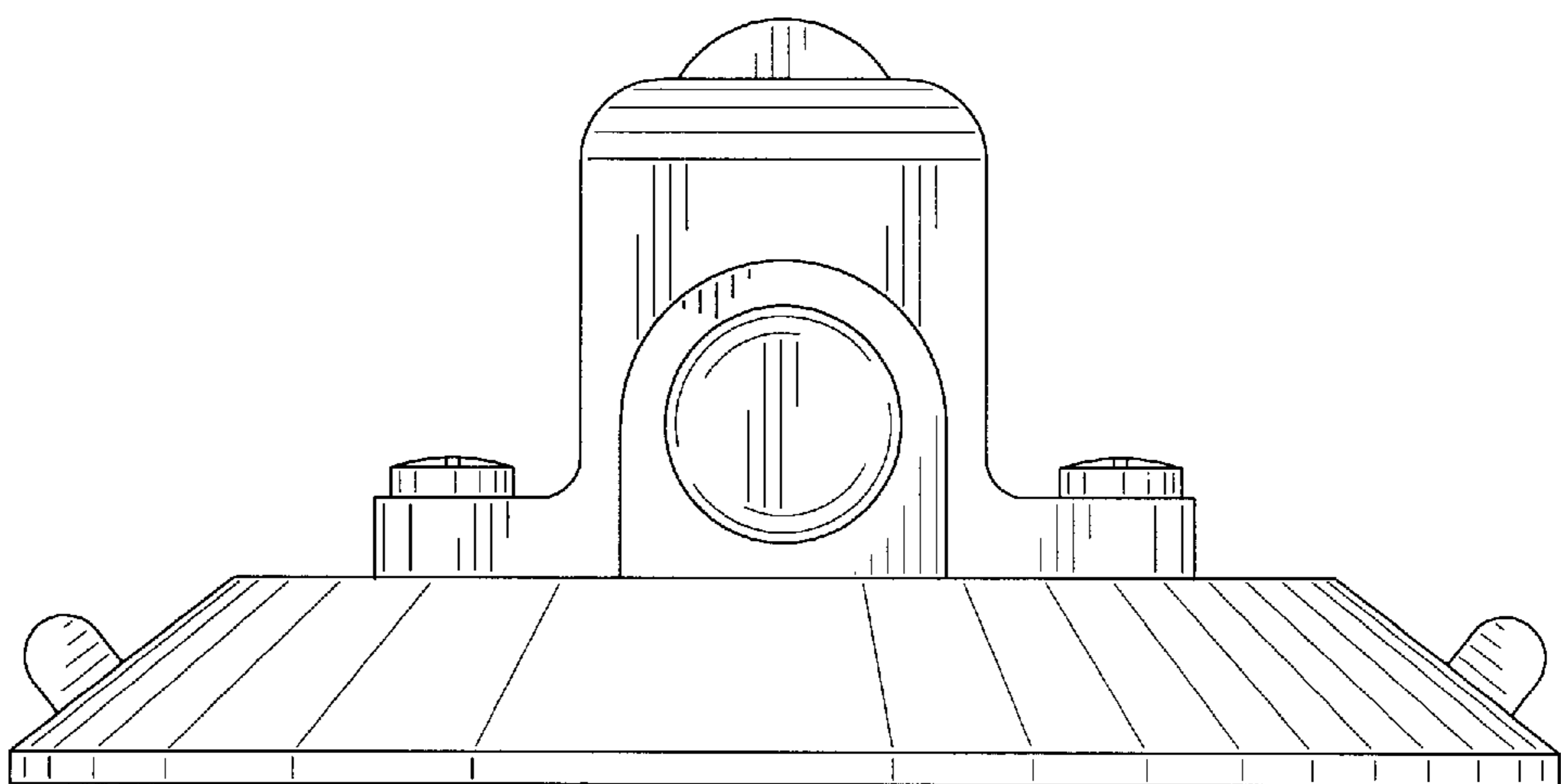

FIG. 3



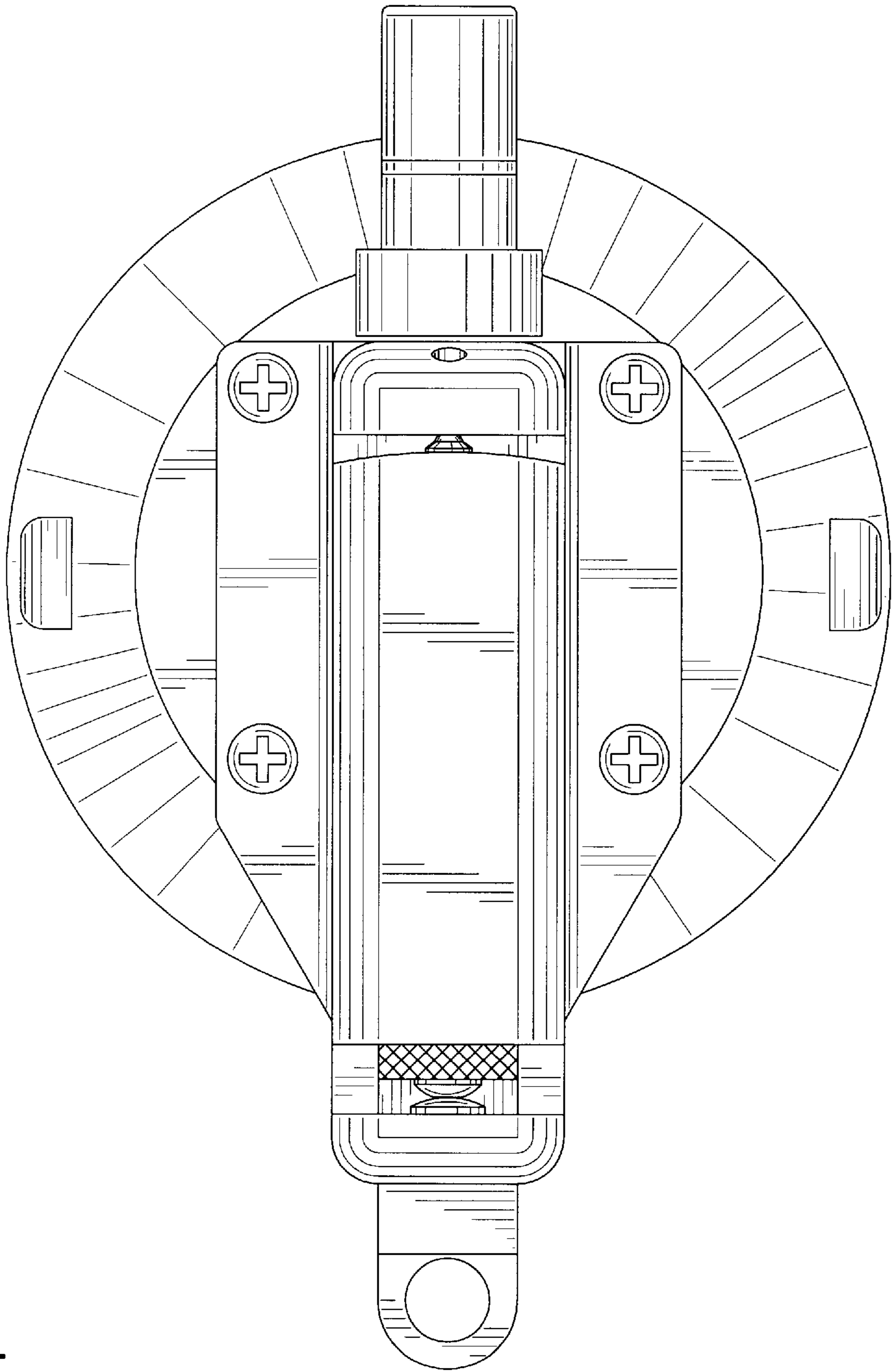

FIG. 4

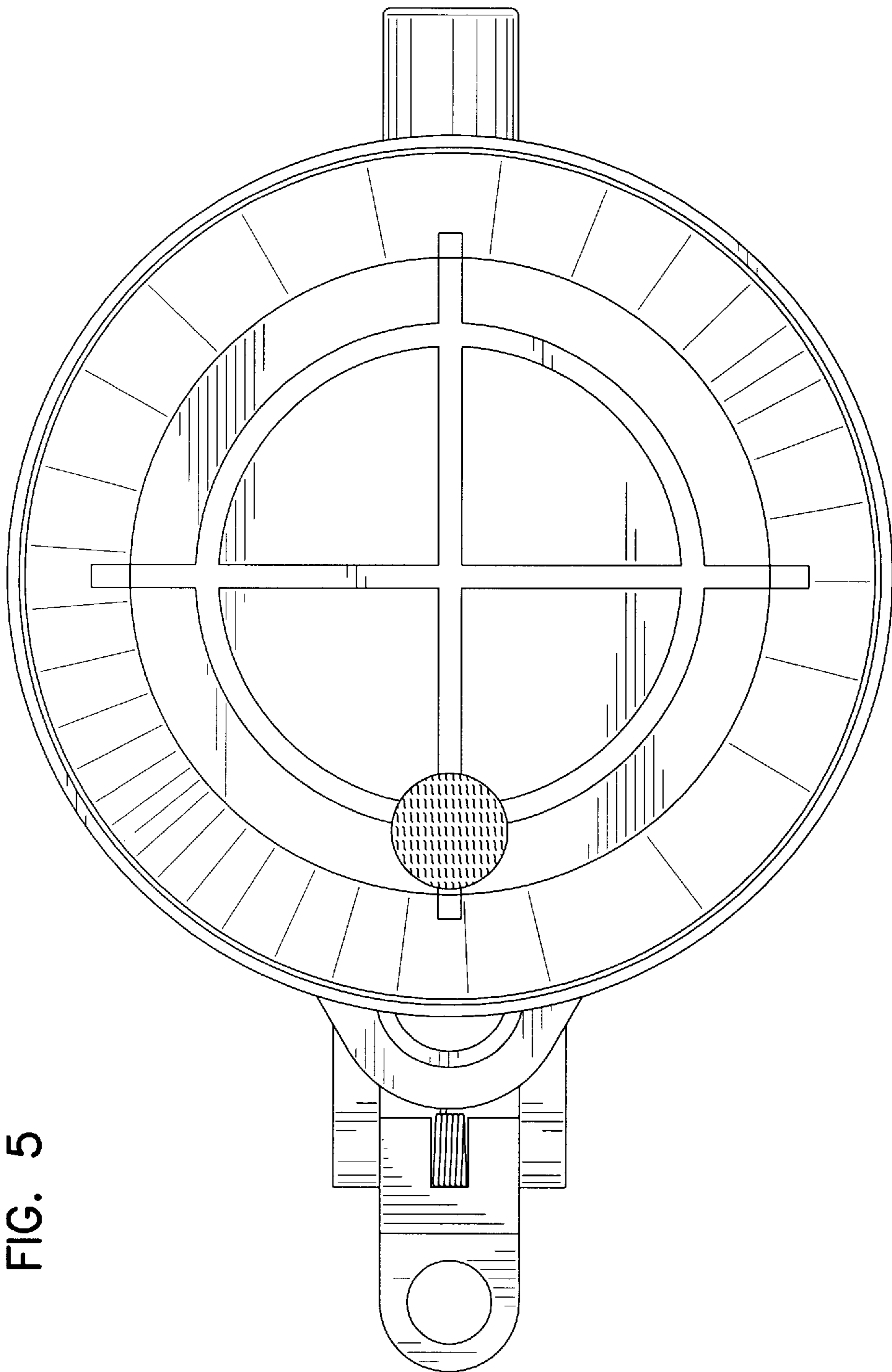

FIG. 5

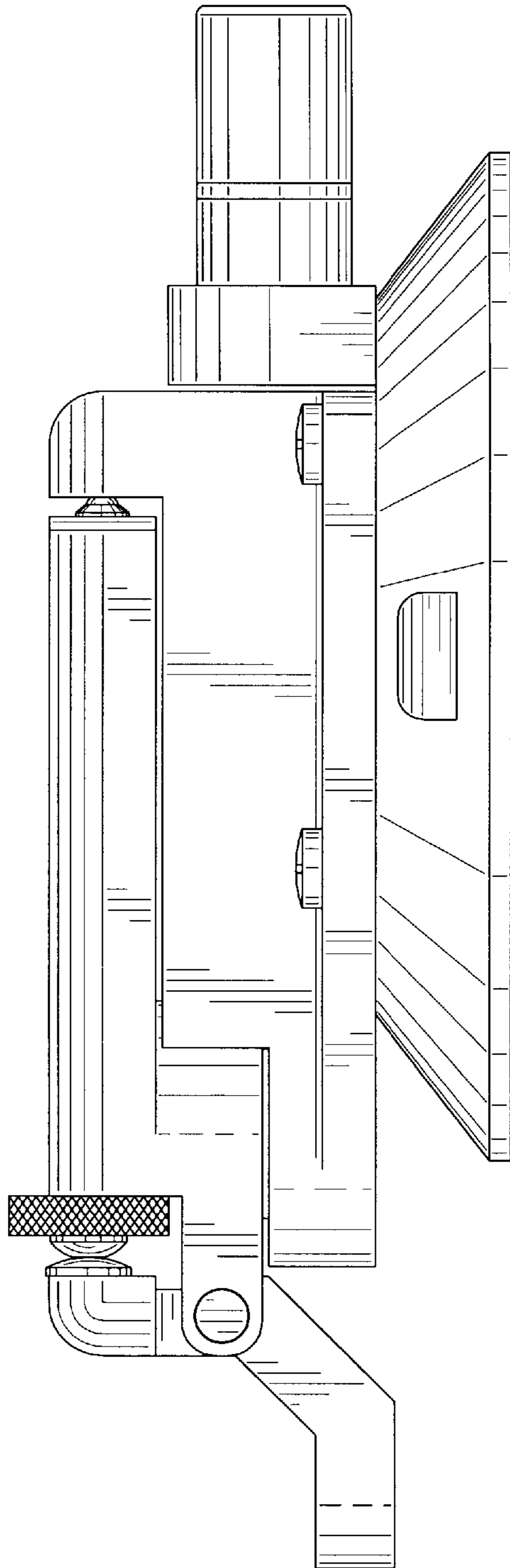

FIG. 6