



US00D406022S

United States Patent [19]
Wu

[11] **Patent Number: Des. 406,022**

[45] **Date of Patent: **Feb. 23, 1999**

[54] **PULL TOOL FOR UNLOCKING A VEHICLE DOOR WITHOUT KEY**

5,440,954 8/1995 Stevens 81/488 X

[76] Inventor: **Kuo-Shen Wu**, No. 10, Alley 14 Lane 74, Pa Te Road, Section 3, Taipei, Taiwan

[**] Term: **14 Years**

[21] Appl. No.: **40,475**

[22] Filed: **Jun. 19, 1995**

OTHER PUBLICATIONS

Neuses Inc, 1982, Cat #81A, p. 8.

Primary Examiner—Prabhakar G. Deshmukh
Attorney, Agent, or Firm—Ladas & Parry

[57] **CLAIM**

The ornamental design for a pull tool for unlocking a vehicle door without key, as shown and described.

DESCRIPTION

FIG. 1 is a perspective view of the first embodiment of the pull tool for unlocking a vehicle door without key, according to my new design;

FIG. 2 is a top plan view thereof;

FIG. 3 is a front elevational view thereof;

FIG. 4 is a bottom view thereof;

FIG. 5 is a rear elevational view thereof;

FIG. 6 is a left side elevational view thereof;

FIG. 7 is a right side elevational view thereof;

FIG. 8 is a perspective view of the second embodiment of the pull tool for unlocking a vehicle door without key, to be used by traffic constables according to my new design;

FIG. 9 is a top plan view thereof (symmetric bottom view);

FIG. 10 is a front elevational view thereof;

FIG. 11 is a bottom view thereof;

FIG. 12 is a rear elevational view thereof;

FIG. 13 is a left side elevational view thereof; and,

FIG. 14 is a right side elevational view thereof.

Related U.S. Application Data

[63] Continuation-in-part of Ser. No. 37,736, Apr. 19, 1995, abandoned.

[51] **LOC (6) Cl.** **08-05**

[52] **U.S. Cl.** **D8/14**

[58] **Field of Search** D8/14, 88, 89, D8/16, 321, 349; 254/120, 113; 81/488, 15.9; 72/458

[56] **References Cited**

U.S. PATENT DOCUMENTS

D. 344,665	3/1994	Baker	D8/88
4,622,868	11/1986	Flannigan	81/15.9
4,655,102	4/1987	Parkins	81/15.9
4,683,783	8/1987	Fanberg	81/15.9
4,706,525	11/1987	Fenner	81/15.9
4,873,897	10/1989	Williams	81/15.9
4,882,954	11/1989	Selby	81/15.9
5,123,307	6/1992	Dyer	81/15.9

1 Claim, 4 Drawing Sheets

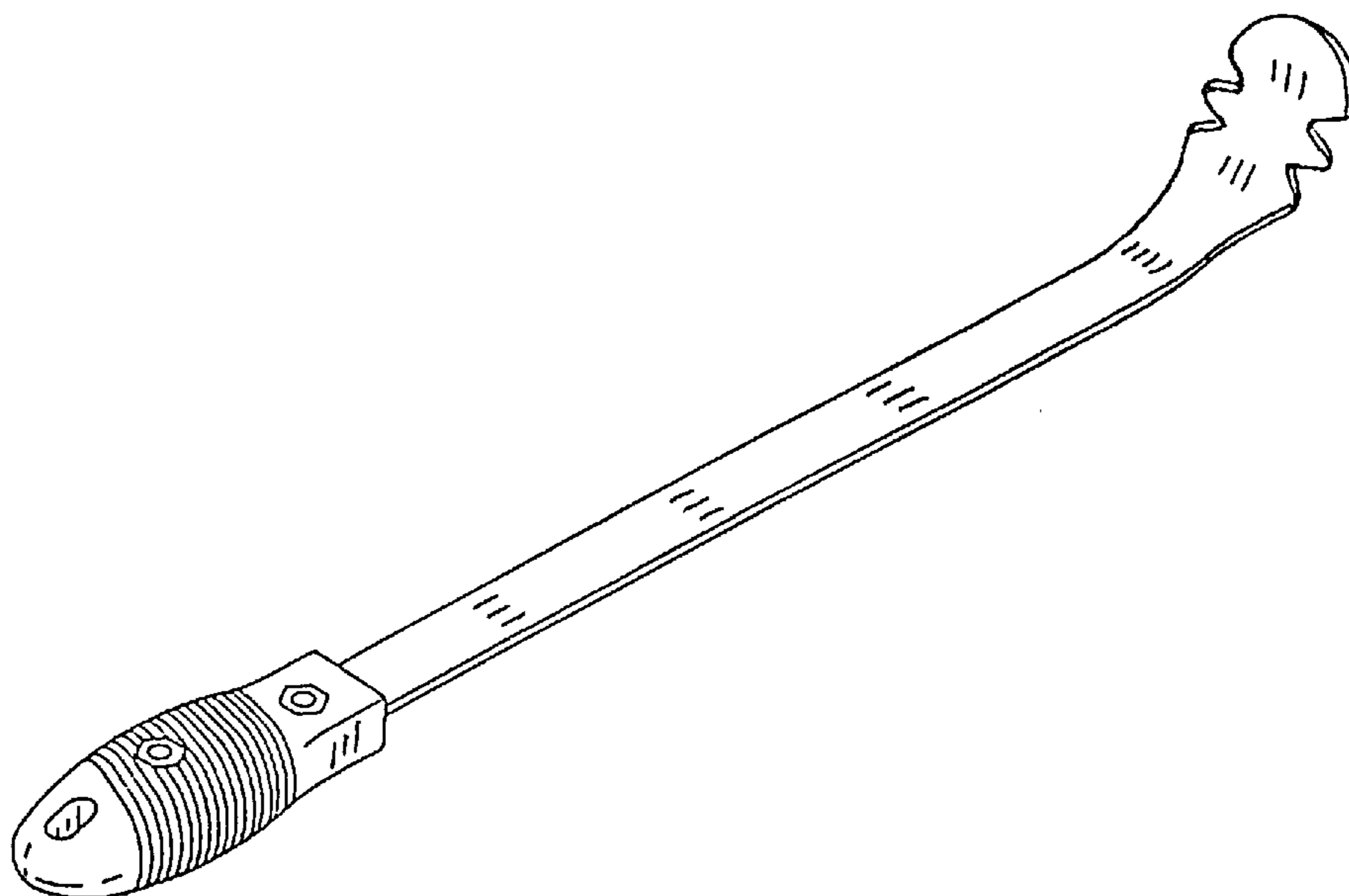

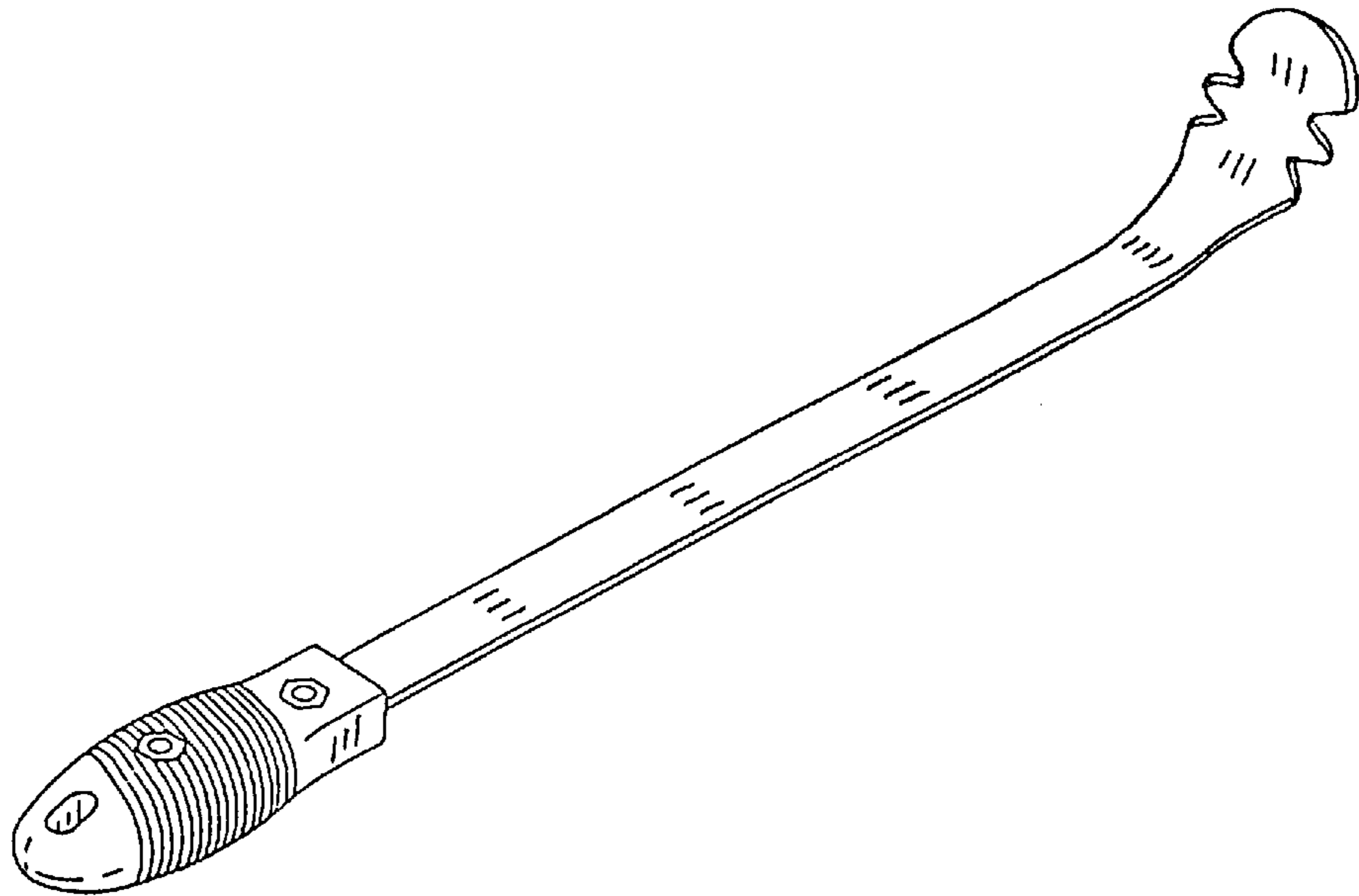

FIG. 1

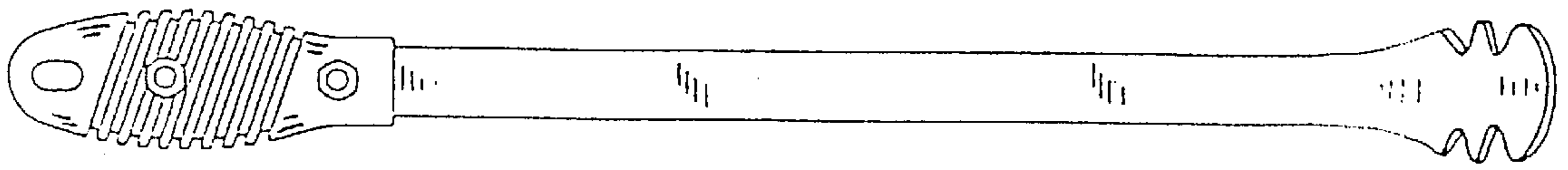

FIG. 2

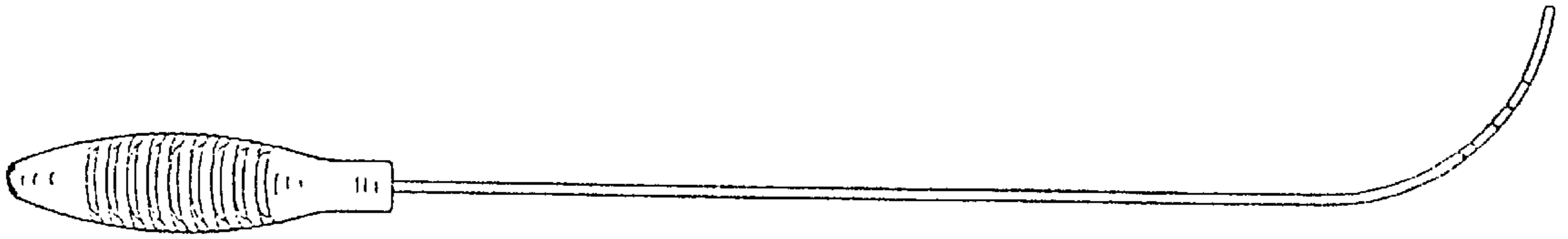

FIG. 3

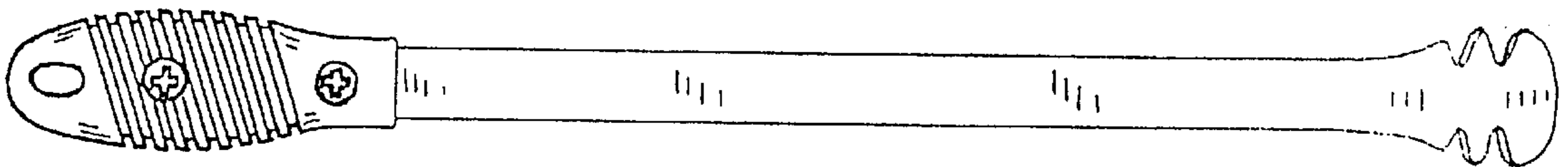

FIG. 4

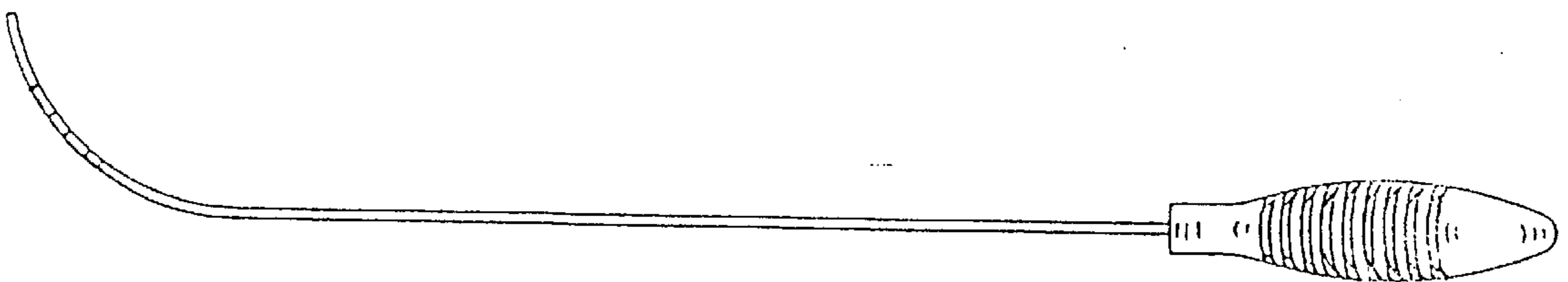

FIG. 5

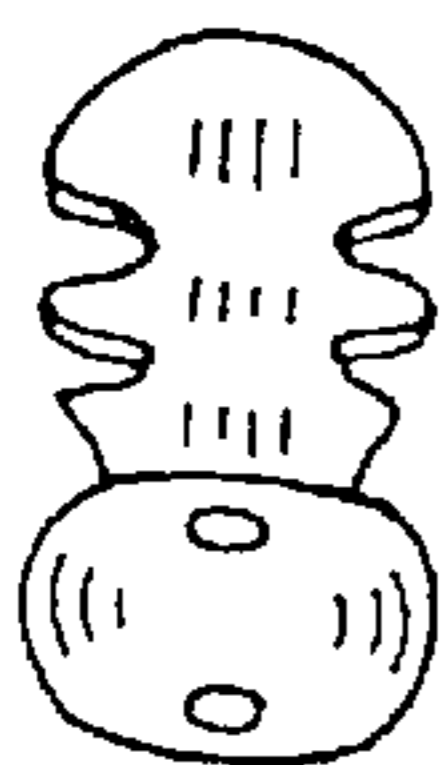

FIG. 6

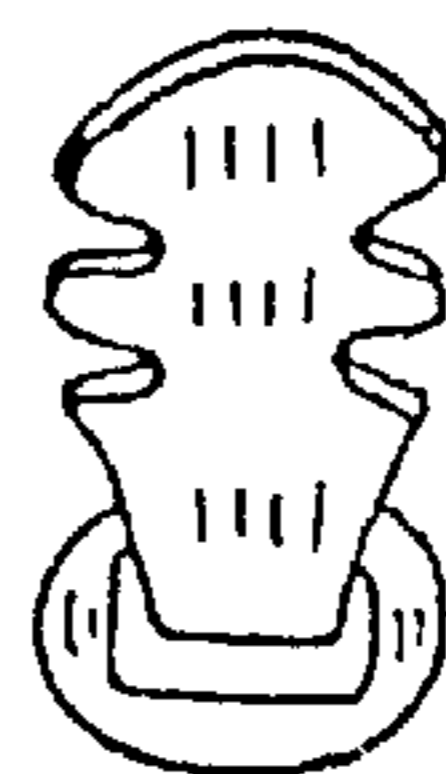

FIG. 7

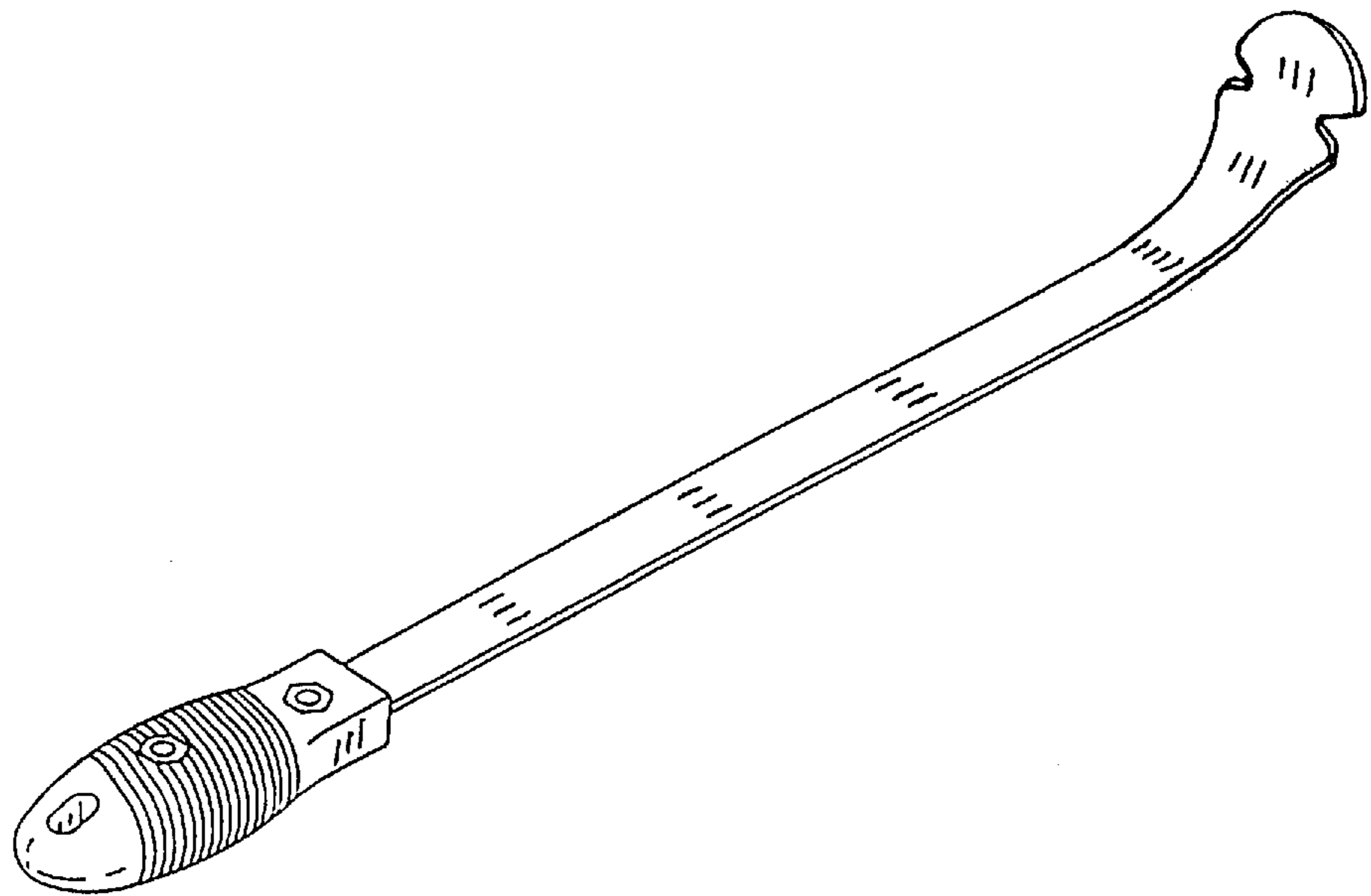

FIG. 8

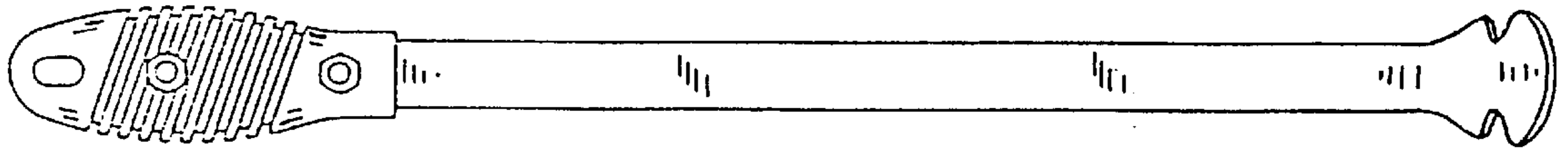

FIG. 9

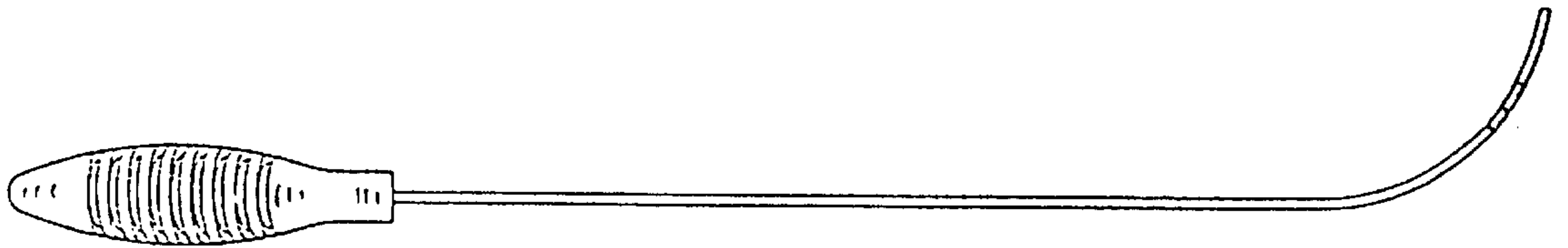

FIG. 10

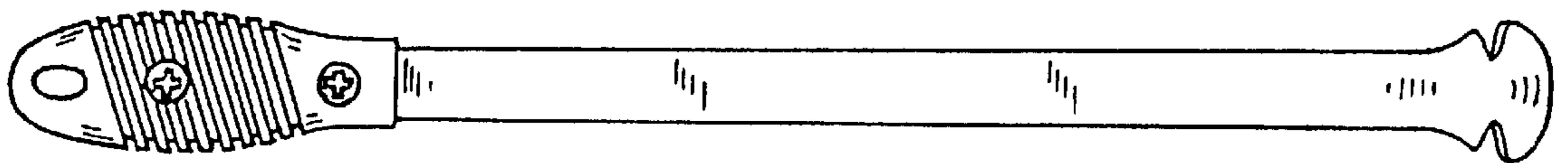

FIG. 11

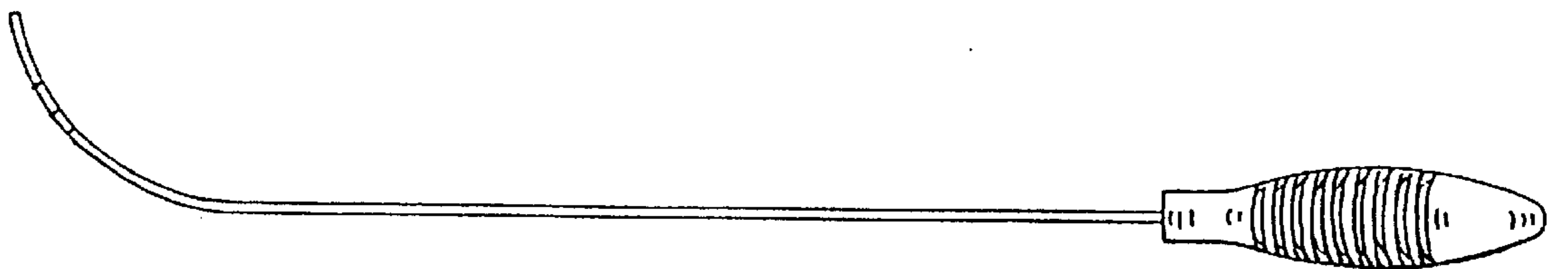

FIG. 12

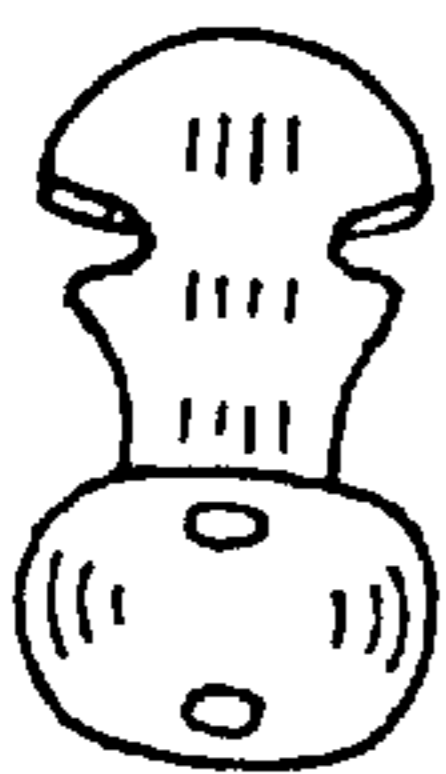

FIG. 13



FIG. 14