



US00D405550S

# United States Patent [19]

[11] **Patent Number: Des. 405,550**

**Sacco et al.**

[45] **Date of Patent: \*\*Feb. 9, 1999**

[54] **EXTERIOR SURFACE CONFIGURATION OF AN INTERIOR LIGHT FIXTURE FOR A MOTOR VEHICLE**

D. 376,437	12/1996	Karlo et al.	.....	D26/28
D. 382,659	8/1997	Kaloustian	.....	D26/28
D. 388,894	1/1998	Yeh	.....	D26/28
D. 391,651	3/1998	Sacco et al.	.....	D26/28

[75] Inventors: **Bruno Sacco**, Sindelfingen; **Peter Pfeiffer**, Boeblingen; **Hans-Dieter Futschik**, Gechingen, all of Germany

*Primary Examiner*—Marcus A. Jackson  
*Attorney, Agent, or Firm*—Evenson, McKeown, Edwards & Lenahan, P.L.L.C.

[73] Assignee: **Daimler-Benz Aktiengesellschaft**, Stuttgart, Germany

### [57] CLAIM

[\*\*] Term: **14 Years**

The ornamental design for a exterior surface configuration of an interior light fixture for a motor vehicle, as shown and described.

[21] Appl. No.: **81,978**

### DESCRIPTION

[22] Filed: **Jan. 12, 1998**

### [30] Foreign Application Priority Data

Jul. 11, 1997 [DE] Germany ..... M 97 06 342.8

[51] **LOC (6) Cl.** ..... **26-06**

[52] **U.S. Cl.** ..... **D26/28**

[58] **Field of Search** ..... D26/28-35; 362/147, 362/404-408, 432, 364, 365, 366

FIG. 1 is a front view of an exterior surface configuration of an interior light fixture for a motor vehicle according to our novel design;

FIG. 2 is a side view of an exterior surface configuration of an interior light fixture for a motor vehicle according to our novel design;

FIG. 3 is an edge view from the top of an exterior surface configuration of an interior light fixture for a motor vehicle according to our novel design; and,

FIG. 4 is an edge view from the bottom of an exterior surface configuration of an interior light fixture for a motor vehicle according to our novel design.

The dash line showing depicts environment and is not part of the claimed design.

### [56] References Cited

#### U.S. PATENT DOCUMENTS

D. 324,111	2/1992	Arbisi	.....	D26/28
D. 358,674	5/1995	Ramsey	.....	D26/28
D. 363,999	11/1995	Taylor et al.	.....	D26/28
D. 369,224	4/1996	Karlo et al.	.....	D26/28

**1 Claim, 2 Drawing Sheets**

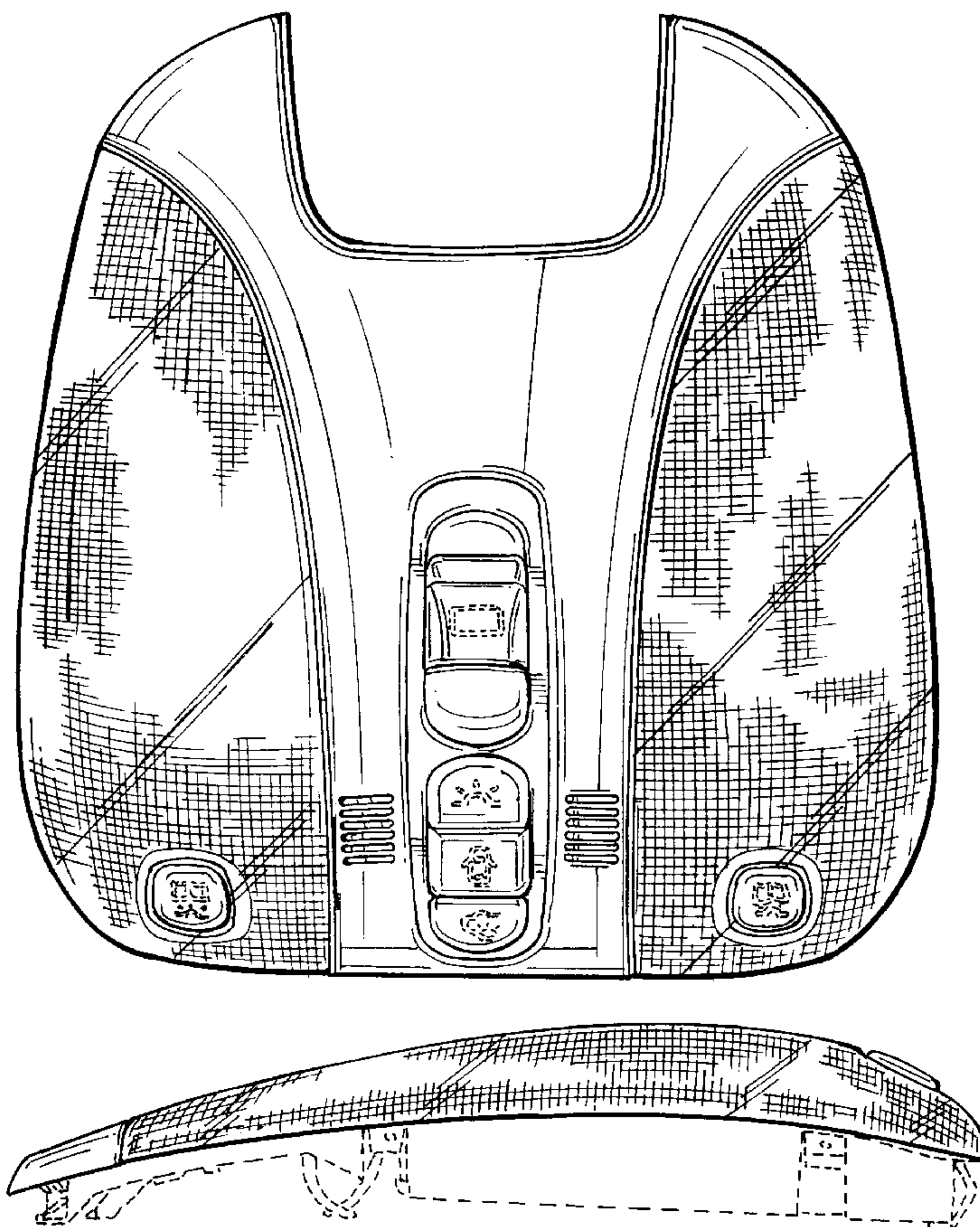

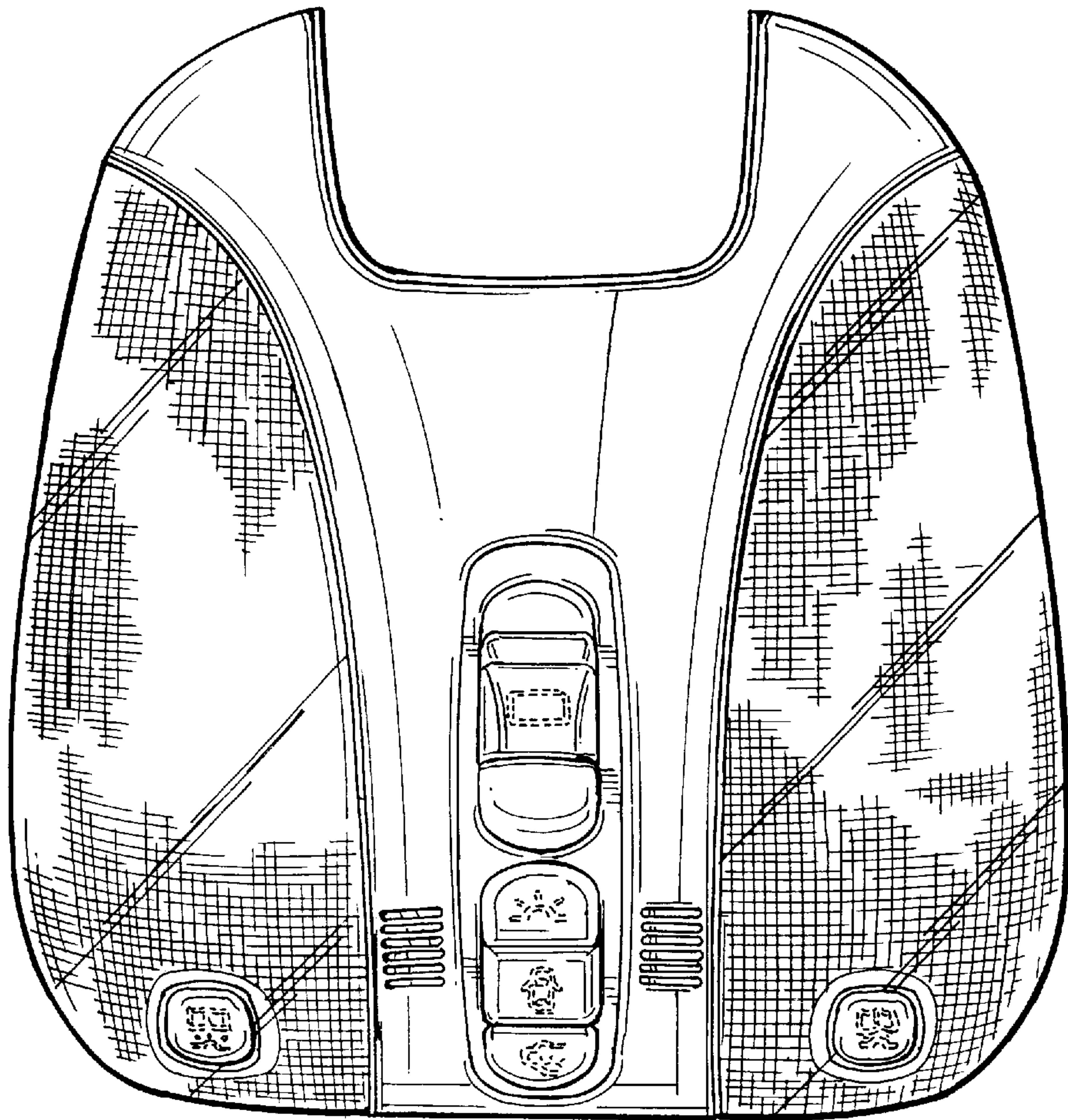

FIG. 1

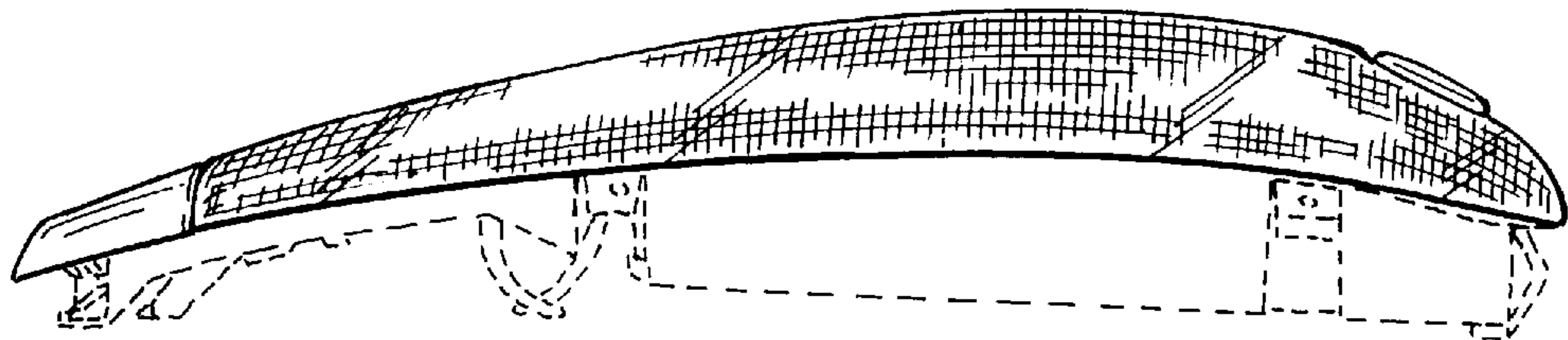

FIG. 2

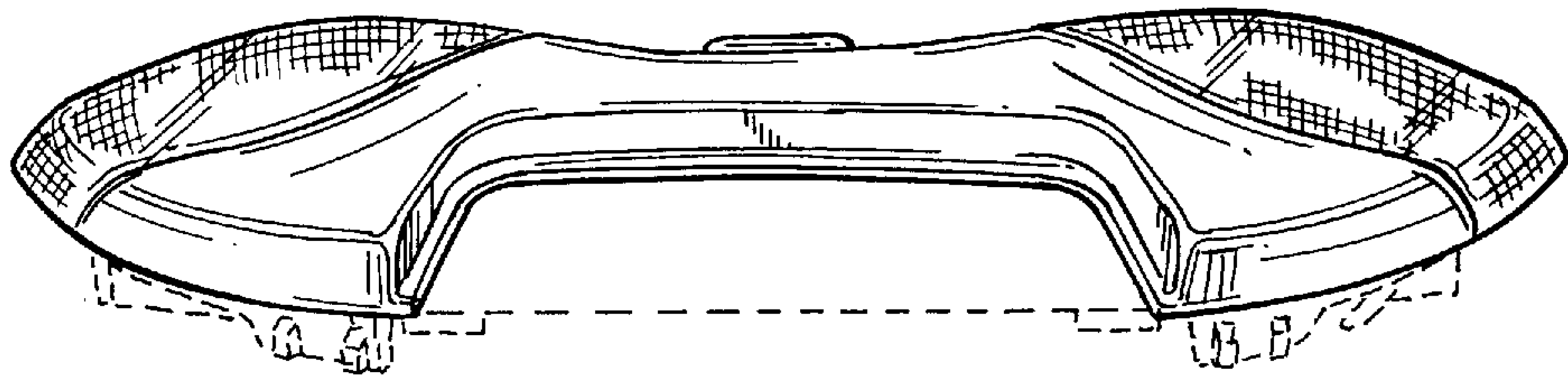

FIG. 3

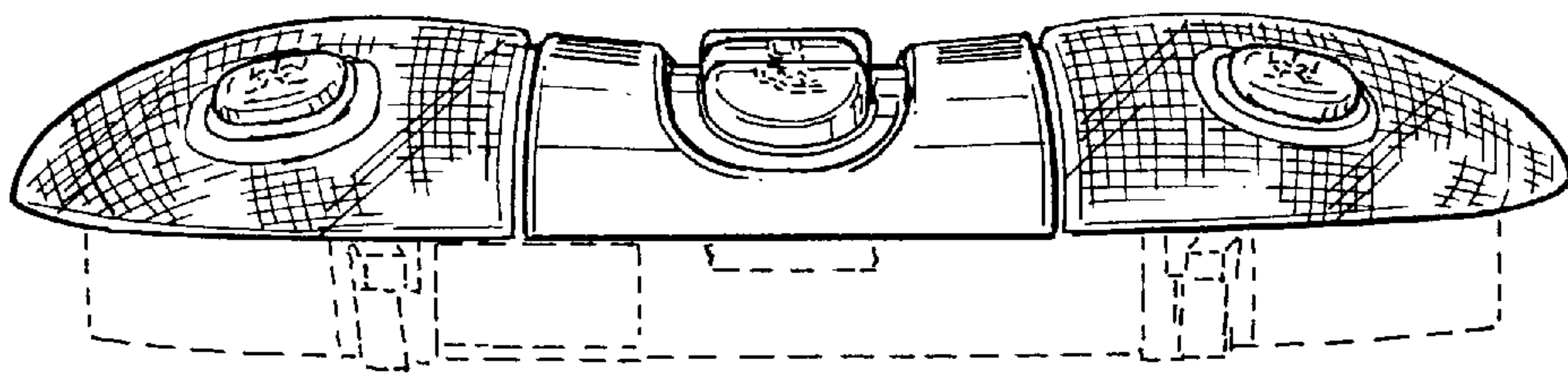

FIG. 4