



US00D405549S

United States Patent [19]

Taylor et al.

[11] **Patent Number: Des. 405,549**

[45] **Date of Patent: **Feb. 9, 1999**

[54] **BICYCLE LAMP**

[75] Inventors: **Harry B. Taylor**, Lafayette; **Paul Klinger**, Westminster, both of Colo.

[73] Assignee: **Schwinn Cycling & Fitness Inc.**, Boulder, Colo.

[**] Term: **14 Years**

[21] Appl. No.: **81,806**

[22] Filed: **Sep. 10, 1997**

Related U.S. Application Data

[63] Continuation of Ser. No. 68,595, Mar. 25, 1997, abandoned.

[51] **LOC (6) Cl.** **26-04**

[52] **U.S. Cl.** **D26/28**

[58] **Field of Search** D26/28-35; 362/61, 362/62, 64, 80, 81, 82, 83, 84, 157, 158, 183-204

[56] References Cited

U.S. PATENT DOCUMENTS

D. 295,324	4/1988	Drane	D26/28
D. 354,147	1/1995	Ueda	D26/28
D. 370,986	6/1996	Koch	D26/28
2,168,939	8/1939	Kraeft	362/72
2,323,900	6/1943	Dempsey	362/72

OTHER PUBLICATIONS

Catalog from Cat Eye Service and Research Center, Boulder, CO; 1997; pp. 1, 3, 4 and 5.

Products Catalog from VistaLite, a division of Bell Sports, Inc., Rantoul, IL, 1995-1996; pp. 1, 6, 7, 8 Systems; available as early as Mar. 25, 1997.

Brochure from Technical Lighting Systems, San Diego, CA, for NiteRider™ Technical Lighting Systems; available as early as Mar. 25, 1997.

Brochure from Turbocat Lighting Systems, Thousand Oaks, CA; 1994.

Brochure from SSB Design Inc., Irvine, CA, for Cygo-Lite; available as early as Mar. 25, 1997.

Brochure from JET Designs, Santa Cruz, CA, for Jet Lites; Sep. 10, 1996.

Brochure from Marwiusa, Olney, IL, for nightpro™; available as early as Mar. 25, 1997.

Brochure from Nightsun Performance Lighting, Pasadena, CA, for Nightsun Max; available as early as Mar. 25, 1997.

Primary Examiner—Marcus A. Jackson
Attorney, Agent, or Firm—Holland & Hart LLP

[57] CLAIM

The ornamental design for a bicycle lamp, as shown.

DESCRIPTION

FIG. 1 is a perspective view of the bicycle lamp of the present invention;

FIG. 2 is a left side elevational view thereof;

FIG. 3 is a front elevational view thereof;

FIG. 4 is a right side elevational view thereof;

FIG. 5 is a rear elevational view thereof;

FIG. 6 is a top plan view thereof; and,

FIG. 7 is a bottom plan view thereof.

1 Claim, 3 Drawing Sheets

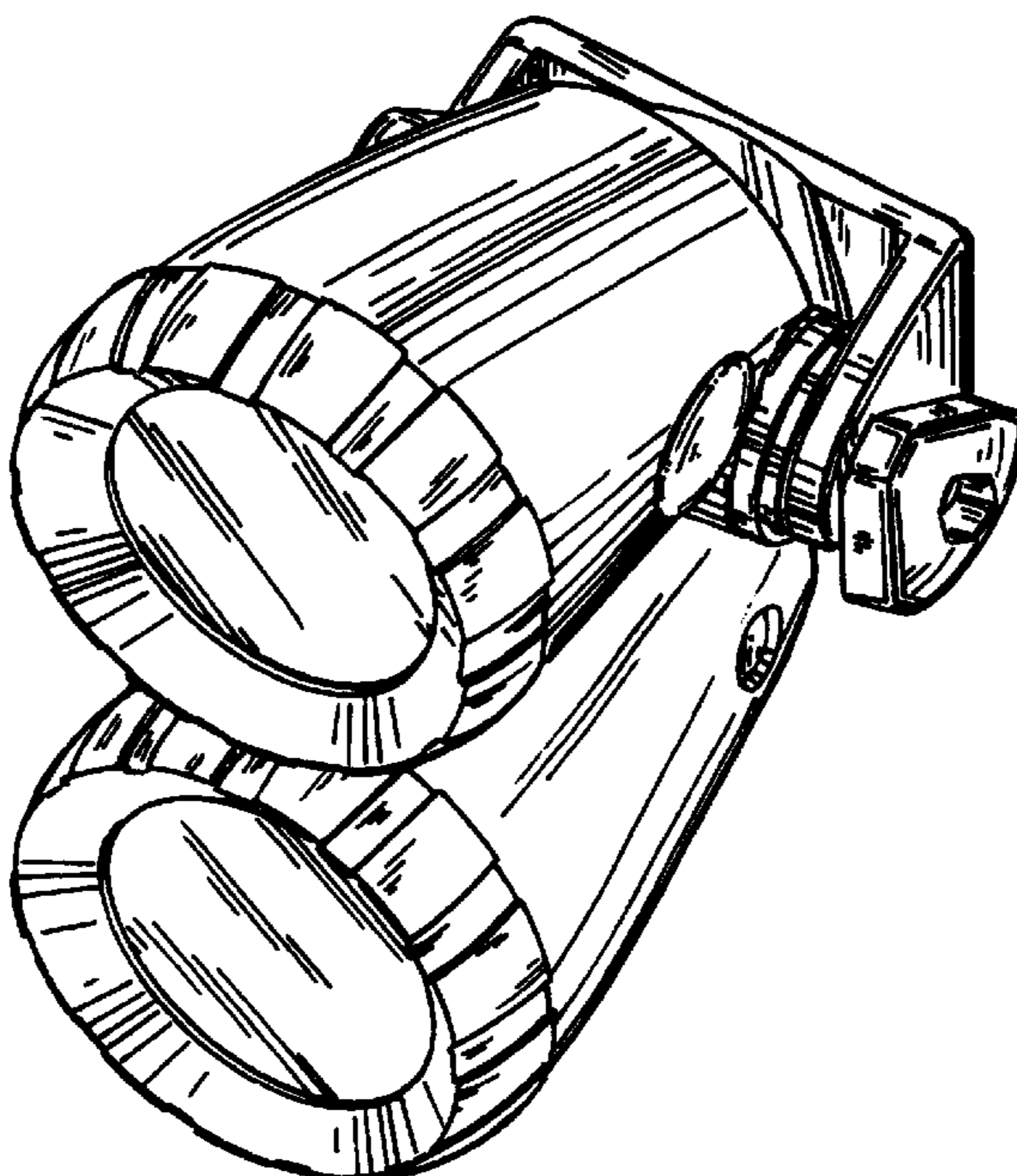

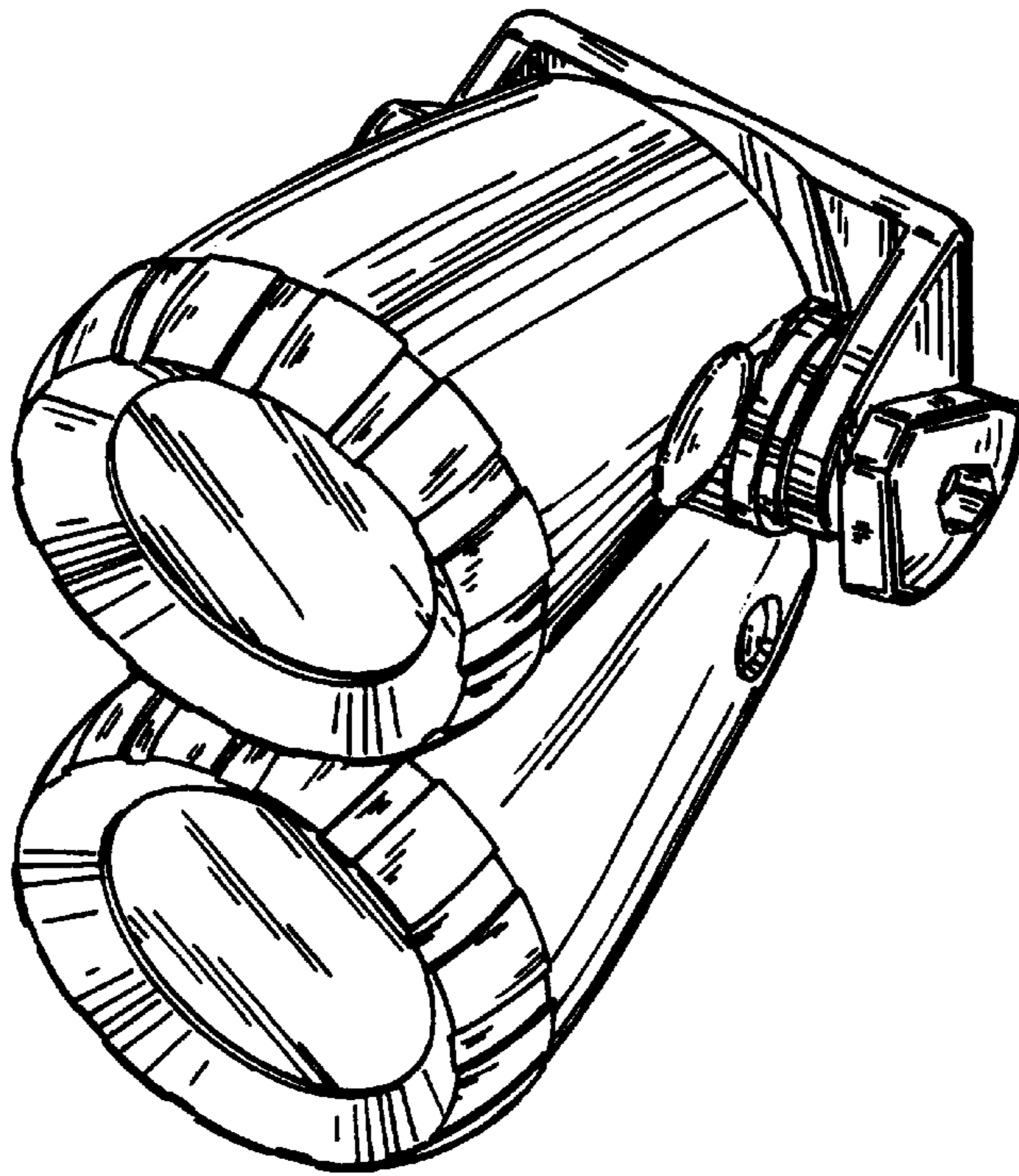

Fig. 1

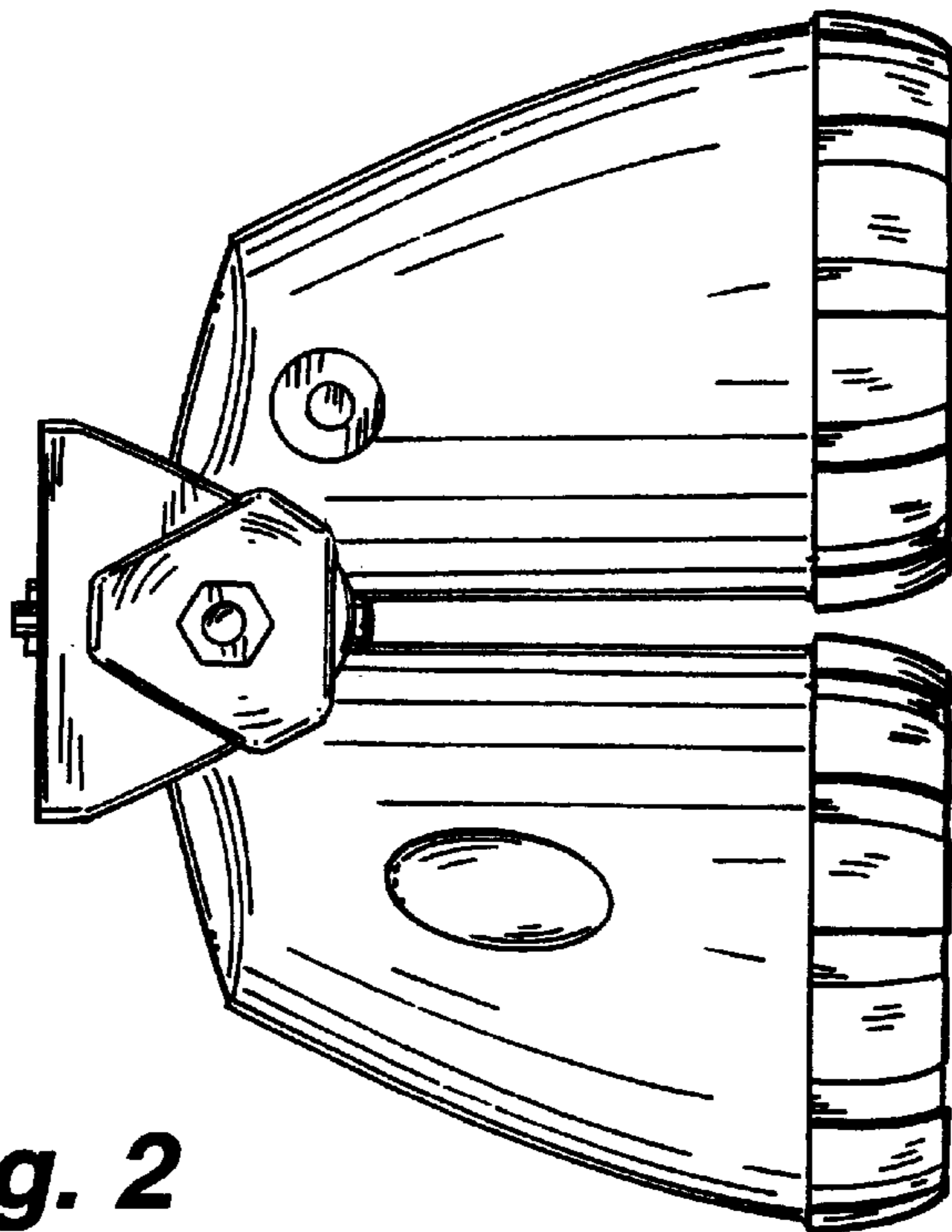

Fig. 2

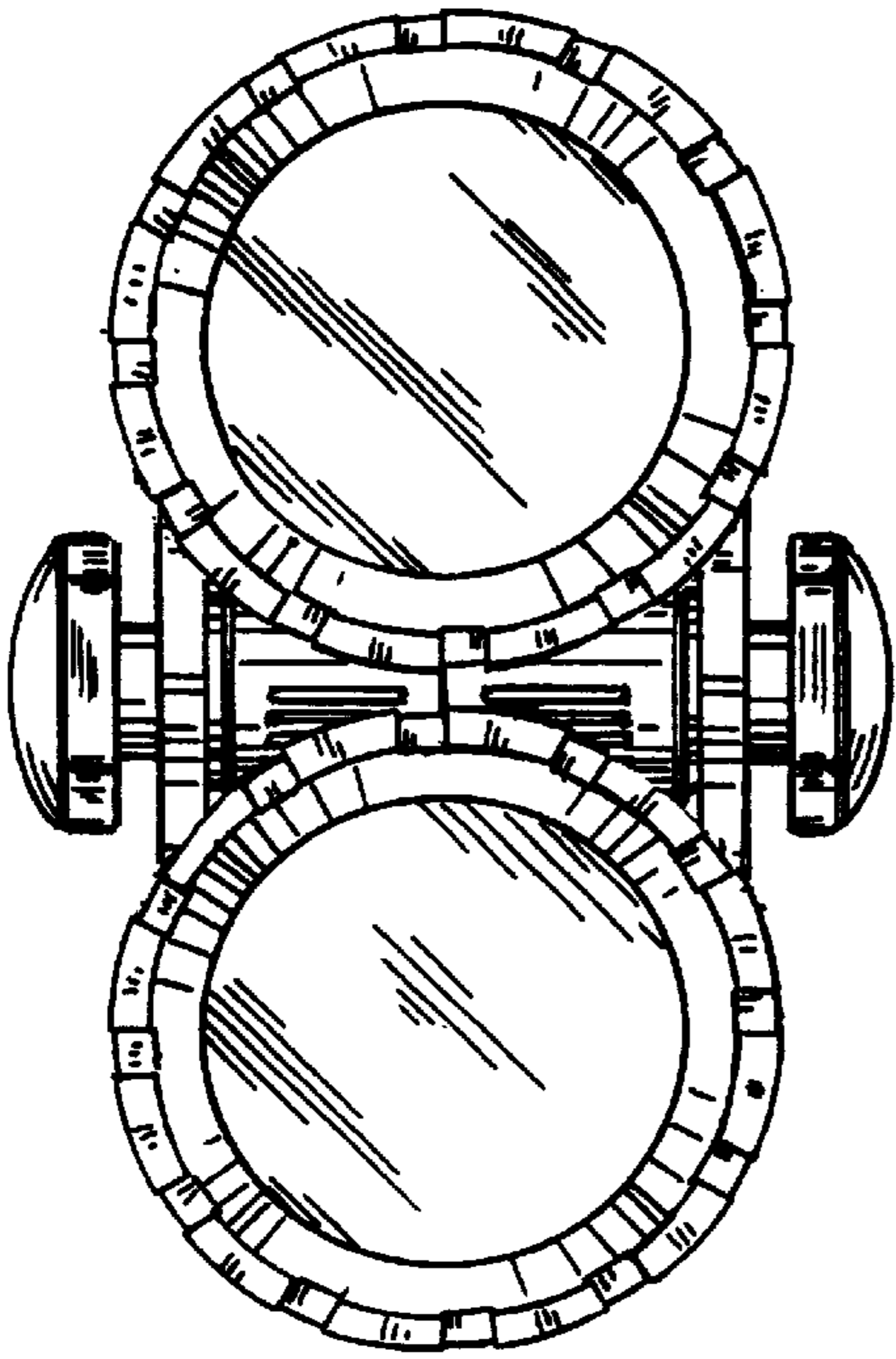

Fig. 3

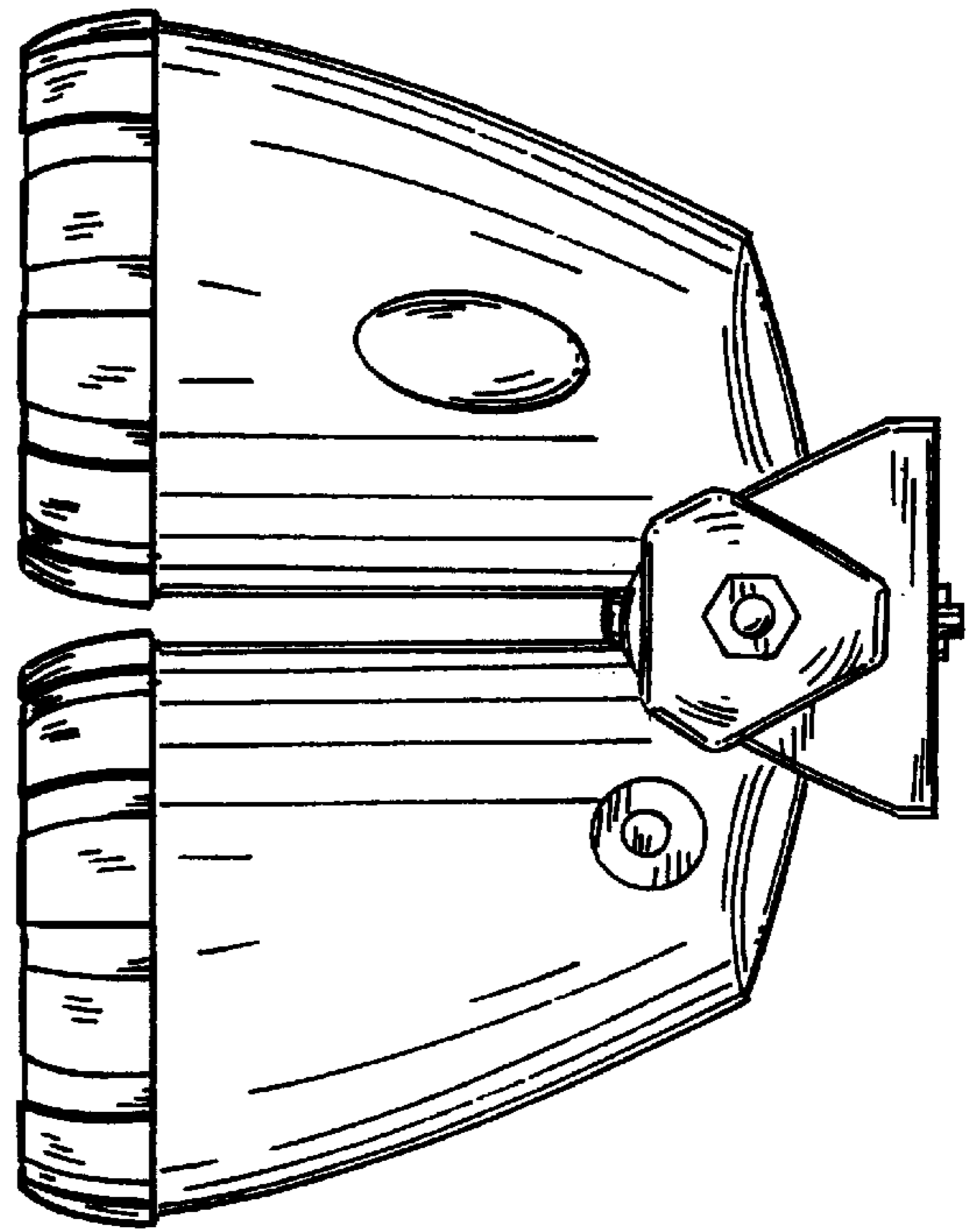

Fig. 4

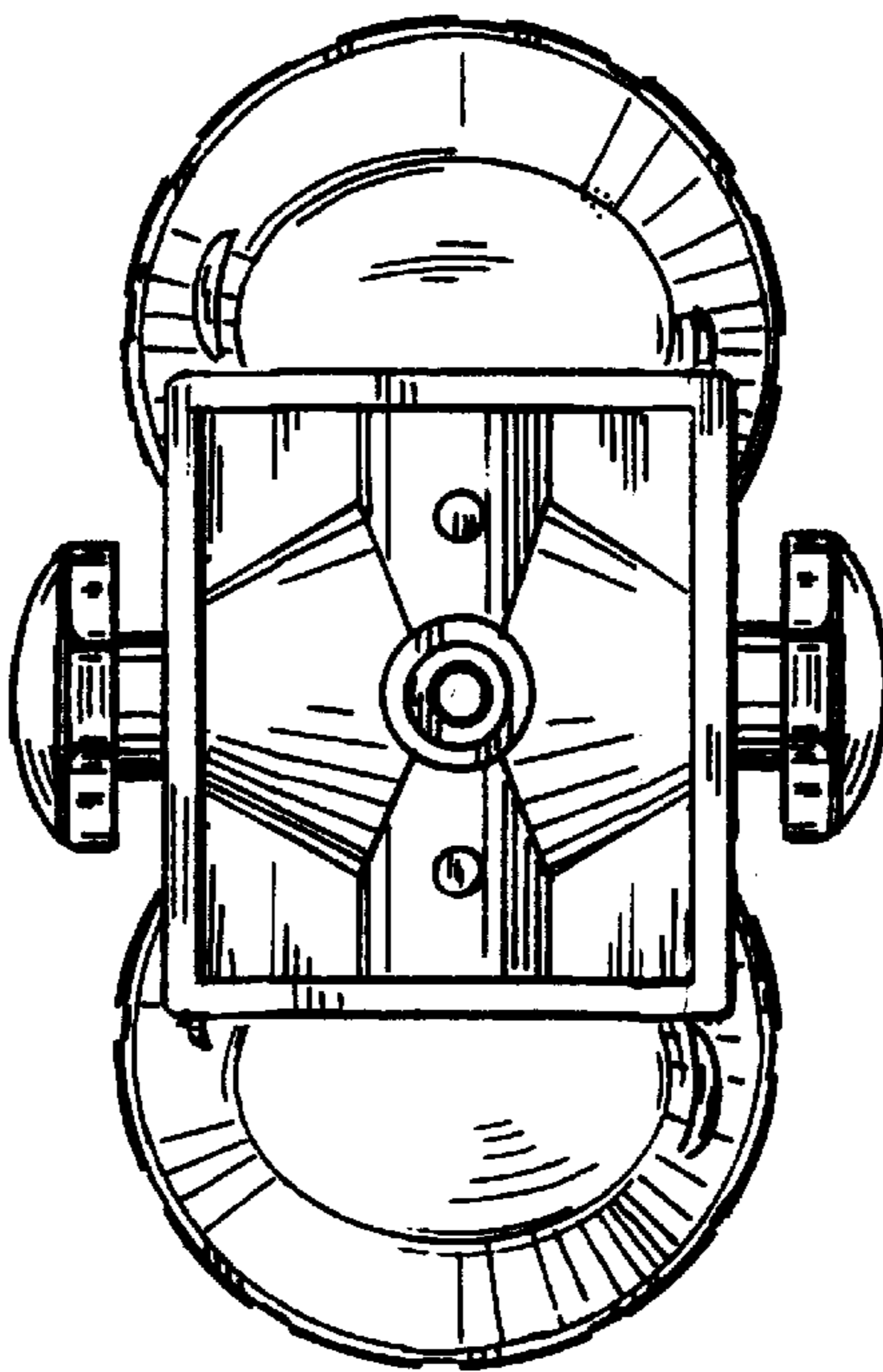

Fig. 5

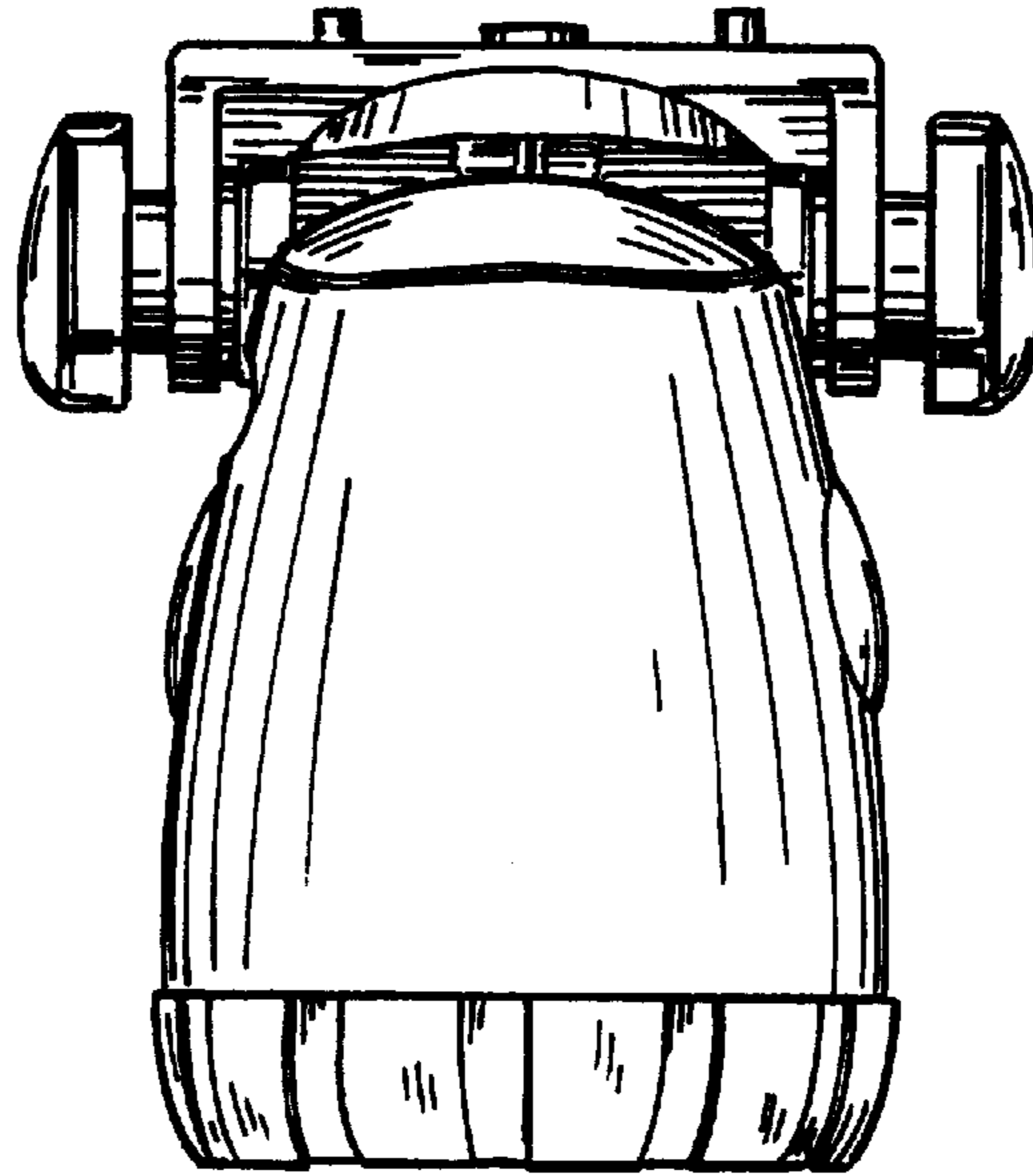

Fig. 6

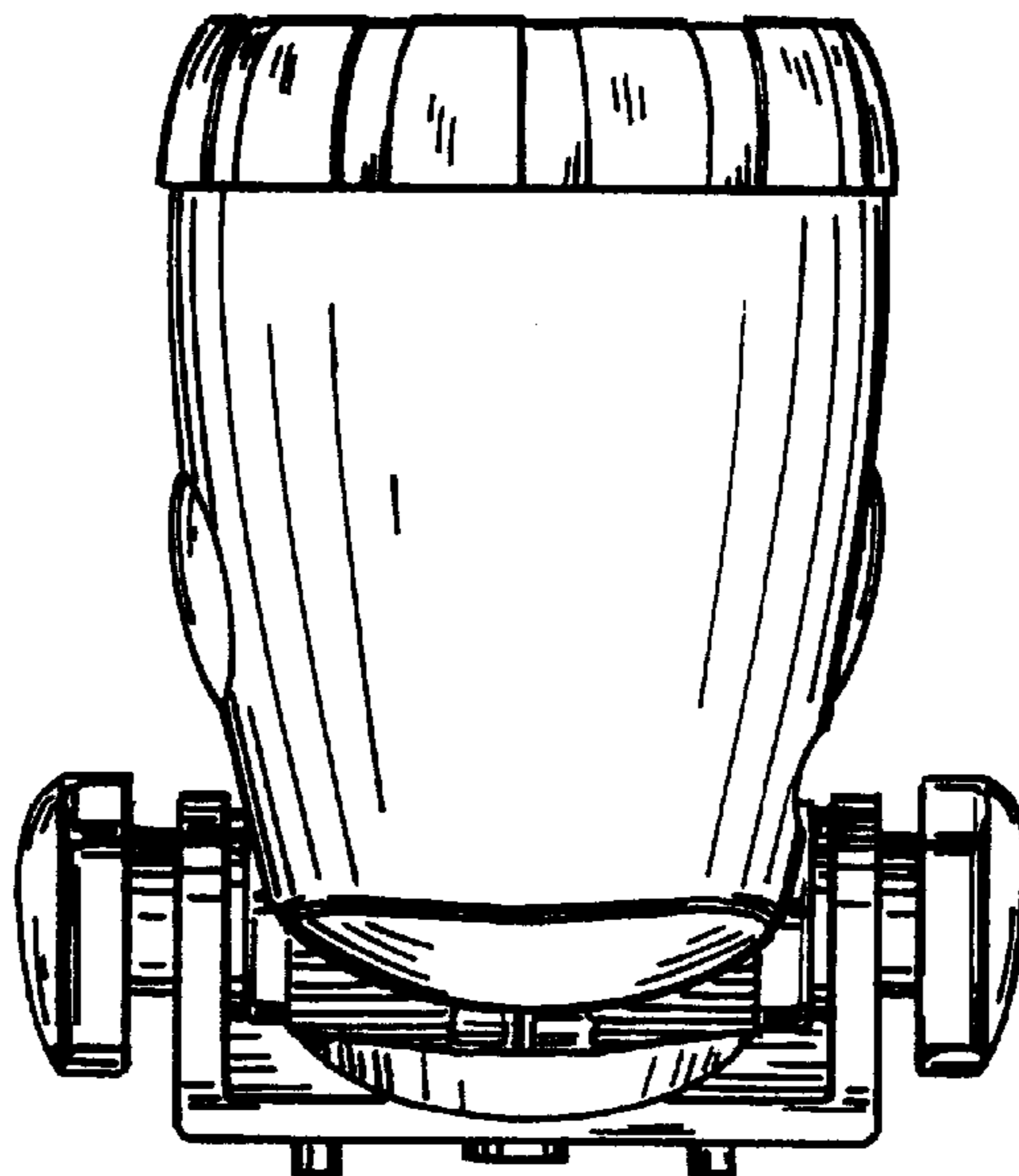

Fig. 7