



US00D405520S

**United States Patent** [19]  
**Birdsell et al.**

[11] **Patent Number: Des. 405,520**  
[45] **Date of Patent: \*\*Feb. 9, 1999**

[54] **PORTABLE FAN**

[75] Inventors: **Walter Birdsell**, Marlborough;  
**Christopher Lozzio**, Medway; **Stanley Gresens**, Charlestown; **Kenneth David Harris, Jr.**, Cambridge, all of Mass.

[73] Assignee: **Honeywell Consumer Products, Inc.**,  
Southborough, Mass.

[\*\*] Term: **14 Years**

[21] Appl. No.: **76,422**

[22] Filed: **Sep. 9, 1997**

**Related U.S. Application Data**

[63] Continuation-in-part of Ser. No. 60,086, Sep. 20, 1996.

[51] **LOC (6) Cl.** ..... **23-04**

[52] **U.S. Cl.** ..... **D23/382; D23/381**

[58] **Field of Search** ..... D23/382, 381,  
D23/335-337, 411, 412, 332, 328; 416/246,  
247; 248/676; 392/365-369

[56] **References Cited**

**U.S. PATENT DOCUMENTS**

- D. 276,550 11/1984 Kouno et al. .... D23/155
- D. 306,903 3/1990 Shin-Chin ..... D23/382
- D. 309,182 7/1990 Hsu ..... D23/382
- D. 312,124 11/1990 Coup et al. .... D23/382

- D. 323,708 2/1992 Wang ..... D23/382
- D. 329,089 9/1992 Coup et al. .... D23/382
- D. 339,859 9/1993 Cheslock ..... D23/382
- D. 344,583 2/1994 Hsu ..... D23/412
- D. 346,019 4/1994 Cheslock et al. .... D23/382
- D. 358,639 5/1995 Chiu ..... D23/411
- D. 359,116 6/1995 Marvin et al. .... D23/382
- D. 367,320 2/1996 Huang ..... D23/382
- D. 372,527 8/1996 Radtke ..... D23/382
- D. 376,005 11/1996 Litvin ..... D23/382

*Primary Examiner*—Lisa Lichtenstein  
*Attorney, Agent, or Firm*—Loletta L. Darden

[57] **CLAIM**

The ornamental design for a portable fan, as shown.

**DESCRIPTION**

FIG. 1 is a front perspective view of a portable fan showing our design;  
 FIG. 2 is a rear perspective view of the portable fan shown in FIG. 1;  
 FIG. 3 is a right side perspective view of the portable fan shown in FIG. 1;  
 FIG. 4 is a left side perspective view of the portable fan shown in FIG. 1;  
 FIG. 5 is a top perspective view of the portable fan shown in FIG. 1; and,  
 FIG. 6 is a bottom perspective view of the portable fan shown in FIG. 1.

**1 Claim, 6 Drawing Sheets**

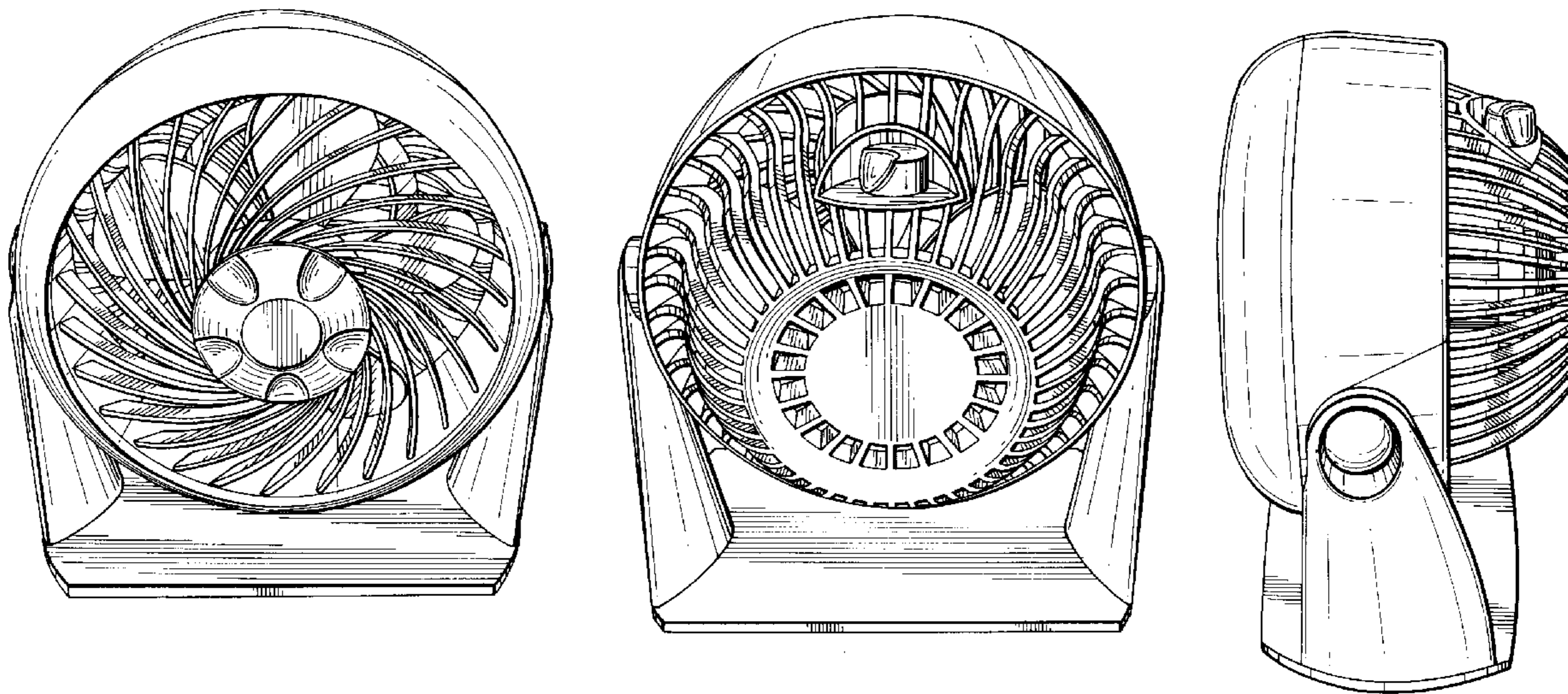

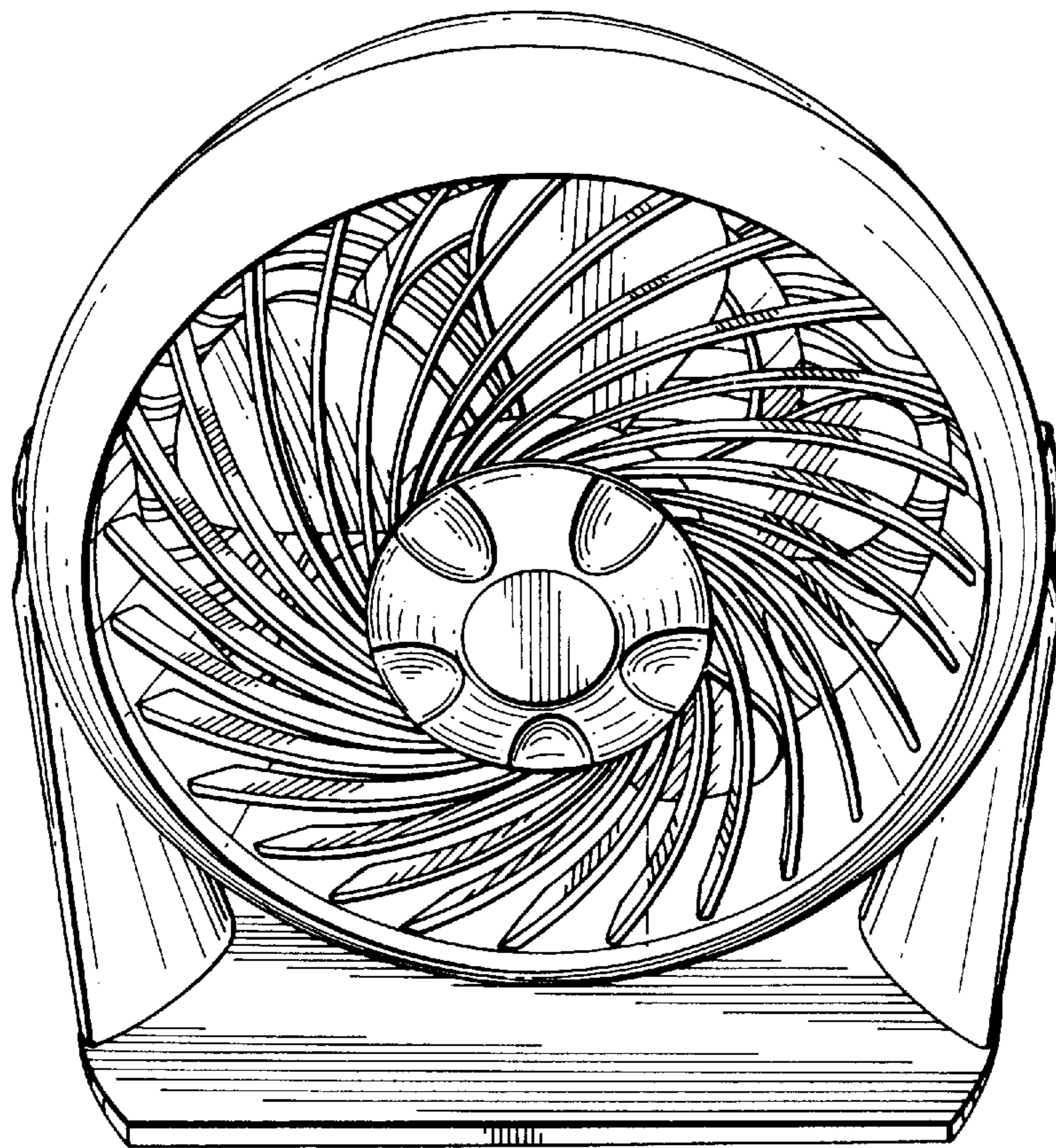

FIG. 1

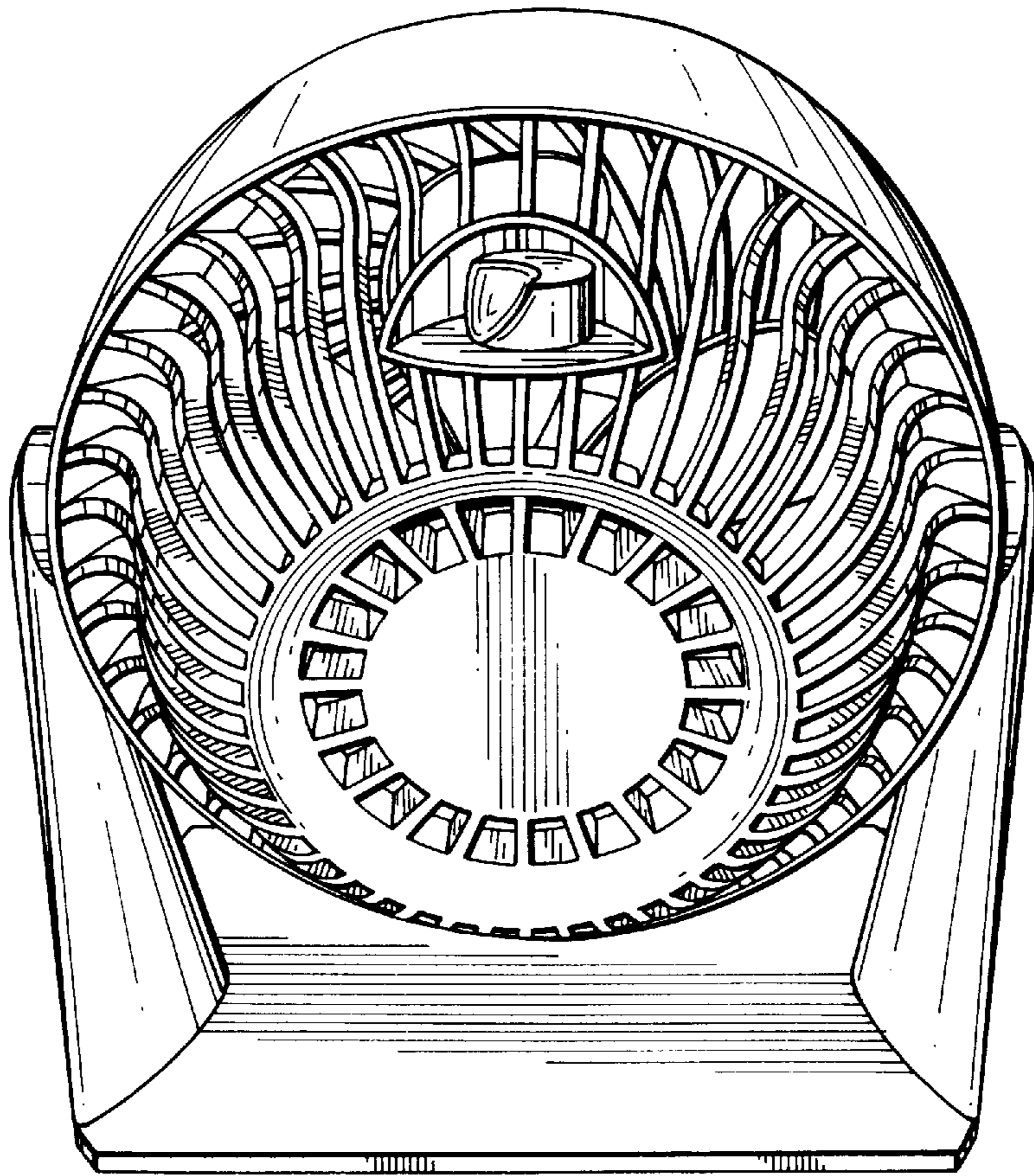

FIG. 2

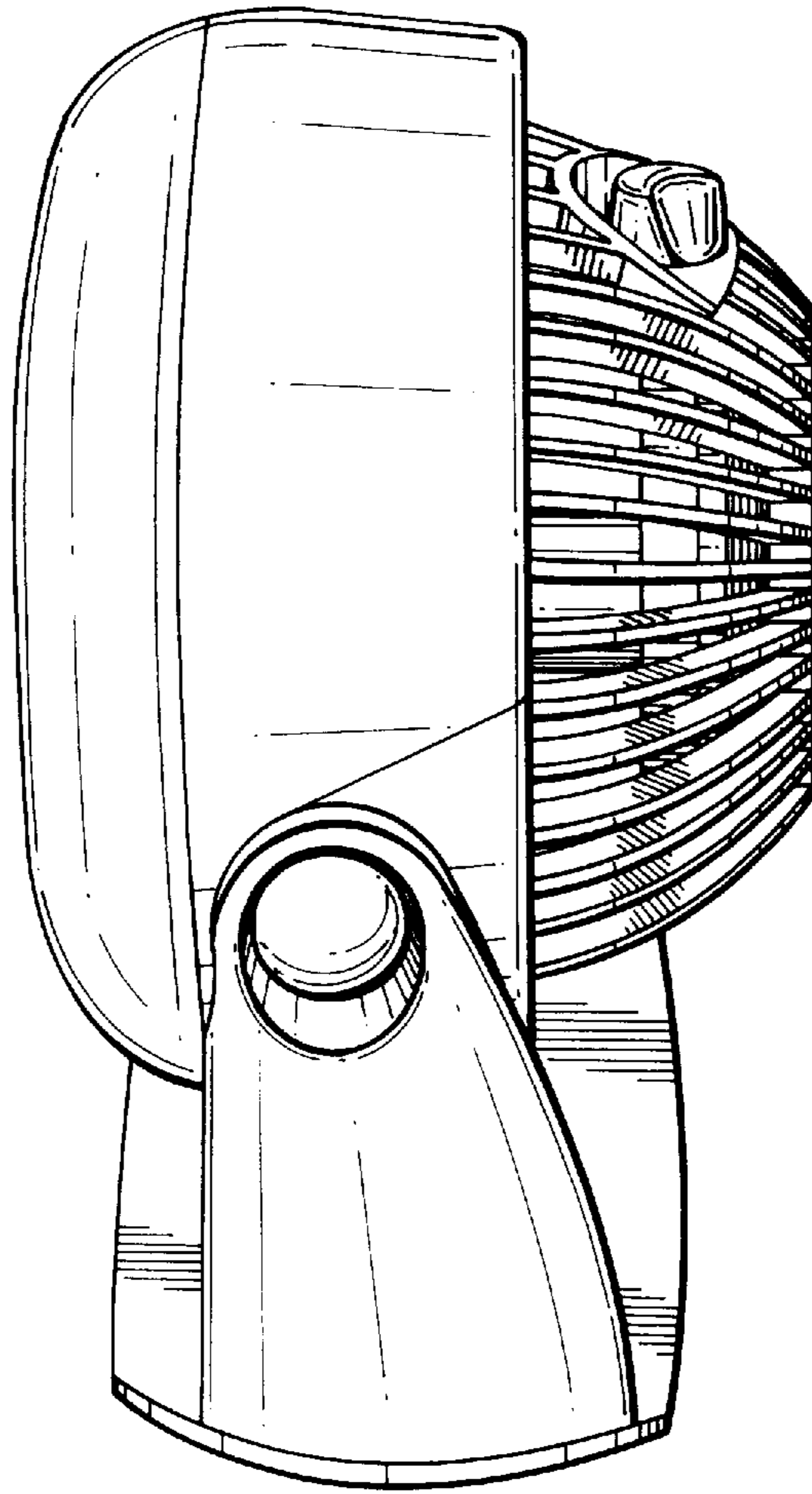

FIG. 3

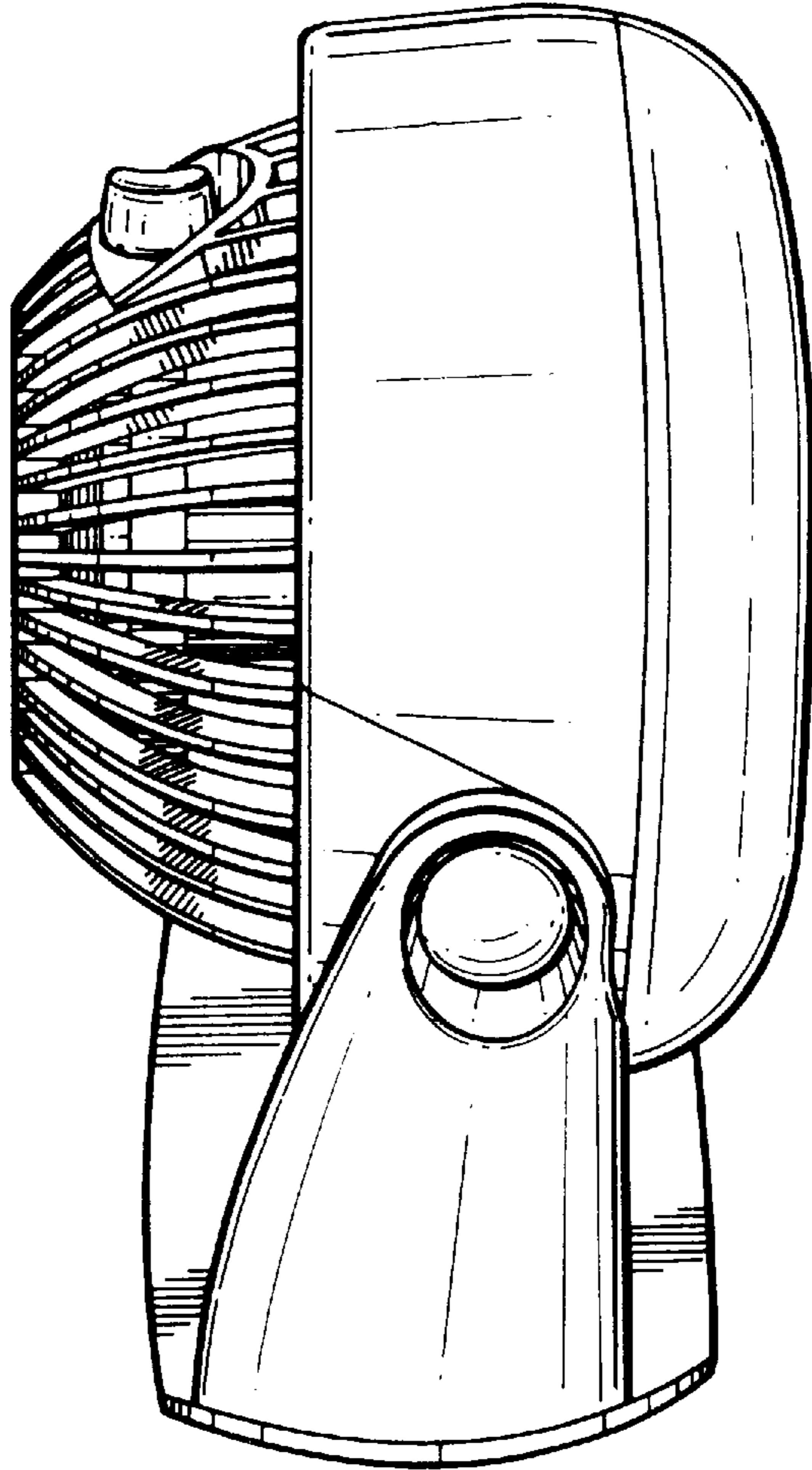

FIG. 4

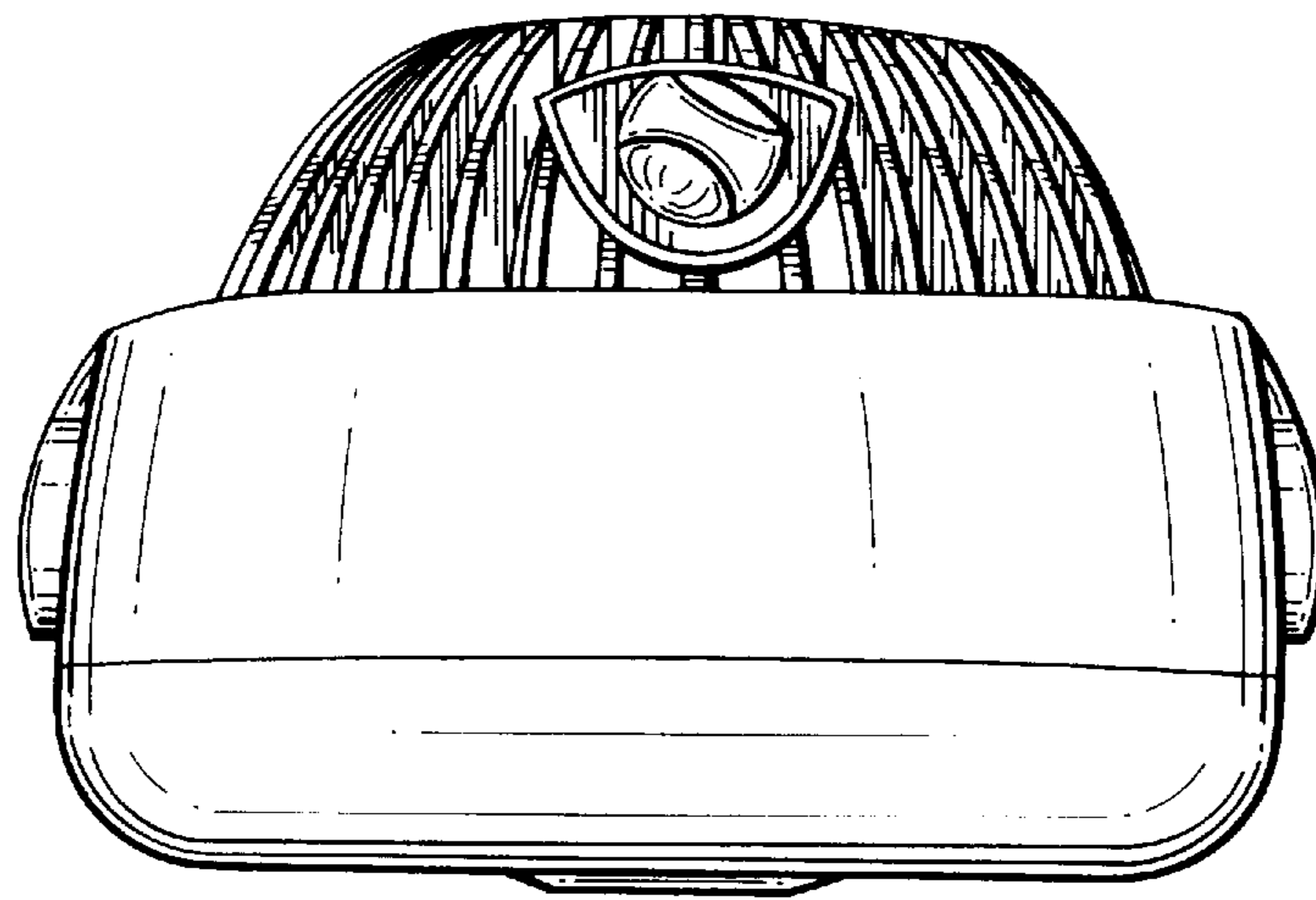

FIG. 5

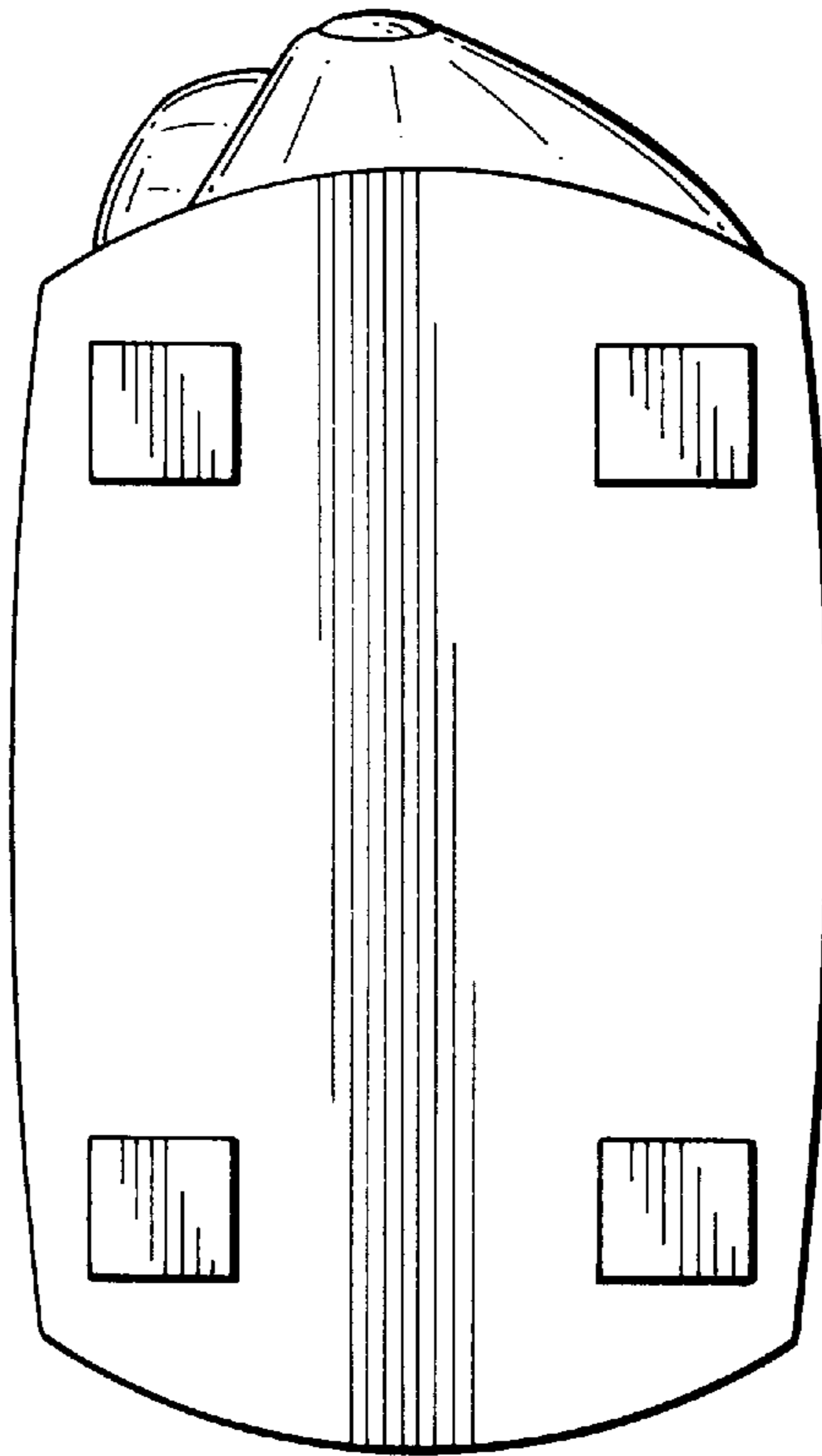

FIG. 6