



US00D405452S

United States Patent [19]

Shinkawa et al.

[11] Patent Number: **Des. 405,452**

[45] Date of Patent: ****Feb. 9, 1999**

[54] **AUTOMOBILE ANTENNA**

[75] Inventors: **Masaki Shinkawa**, Yamato; **Ryouichi Miyakawa**, Tokyo; **Hiroshi Komachi**, Higashimurayama; **Takashi Sakoda**, Kawasaki, all of Japan

[73] Assignee: **Harada Industry Co., Ltd.**, Tokyo, Japan

[**] Term: **14 Years**

[21] Appl. No.: **63,545**

[22] Filed: **Dec. 10, 1996**

[30] **Foreign Application Priority Data**

Jun. 13, 1996 [JP] Japan 8-17313

[51] **LOC (6) Cl.** **14-03**

[52] **U.S. Cl.** **D14/230**

[58] **Field of Search** D14/230-238;
343/900-903, 883, 872, 715, 877

[56] **References Cited**

U.S. PATENT DOCUMENTS

- D. 294,026 2/1988 Shinkawa D14/230
- D. 333,138 2/1993 Egashira et al. D14/234
- D. 333,469 2/1993 Tezuka D14/234

- D. 333,660 3/1993 Miyakawa .
- D. 338,205 8/1993 Egashira et al. D14/234
- D. 387,355 12/1997 Shinkawa et al. D14/230
- D. 391,965 3/1998 Kimura D14/230

Primary Examiner—Ruth McInroy
Attorney, Agent, or Firm—Irving M. Fishman; Michael J. Brown

[57] **CLAIM**

We claim the ornamental design for the automobile antenna, as shown and described.

DESCRIPTION

FIG. 1 is a front elevational view of an automobile antenna showing our new design with the antenna element in a collapsed (hidden) position;

FIG. 2 is a rear elevational view thereof;

FIG. 3 is a top plan view thereof;

FIG. 4 is a bottom plan view thereof;

FIG. 5 is a left side elevational view thereof;

FIG. 6 is a right side elevational view thereof; and,

FIG. 7 is a front elevational view thereof with the antenna element in an extended (visible) position.

The telescoping portion shown in broken lines in FIG. 7 is for illustrative purposes only and forms no part of the claimed design.

1 Claim, 3 Drawing Sheets

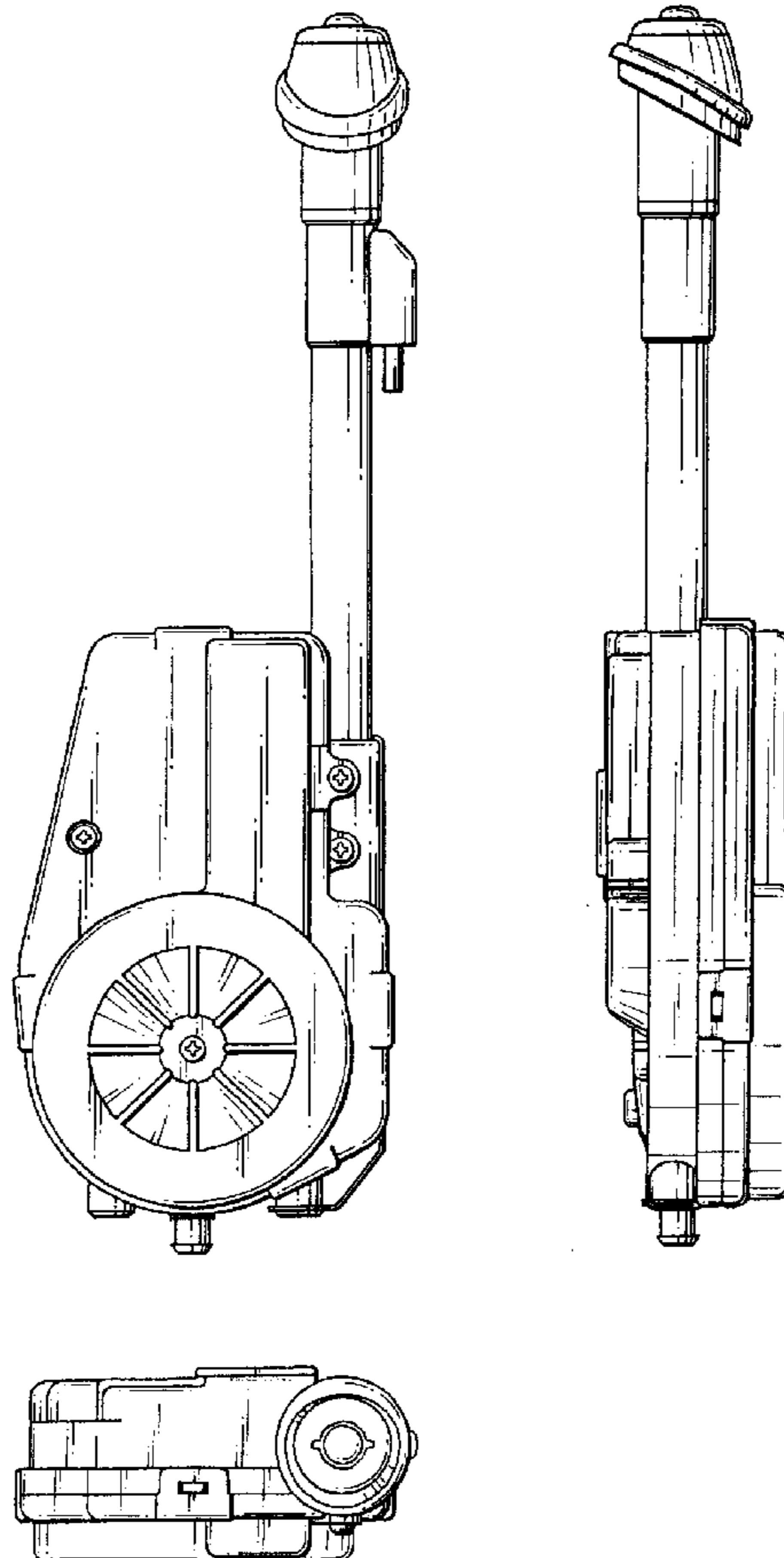

FIG. 1

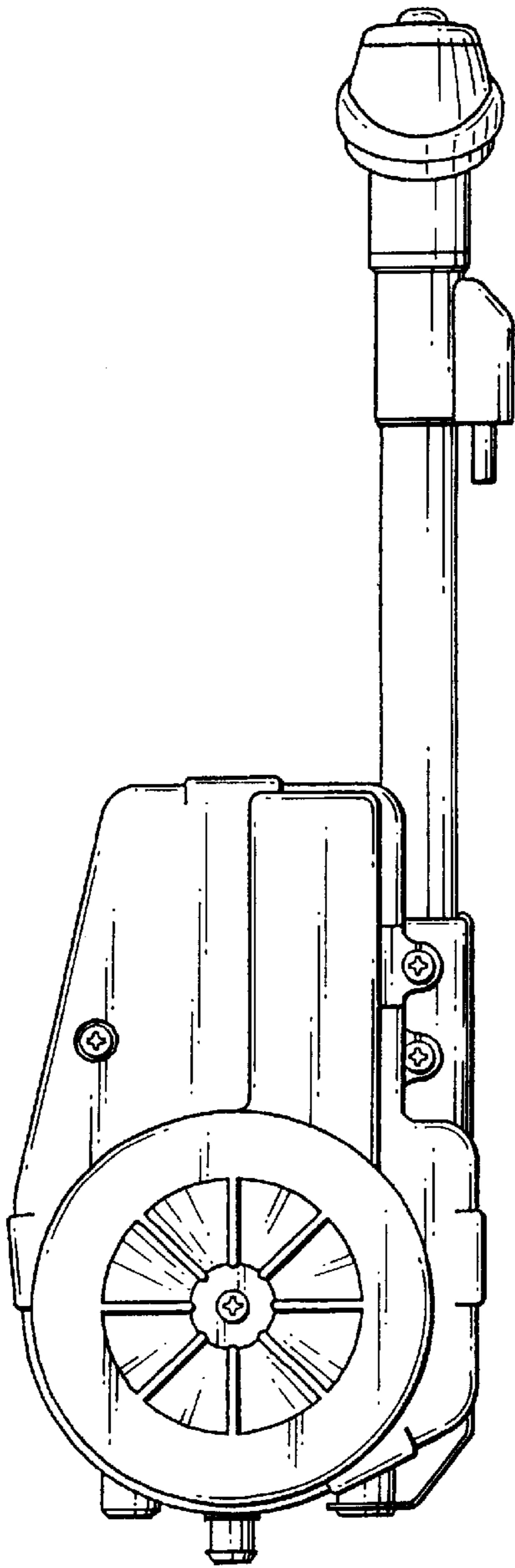

FIG. 2

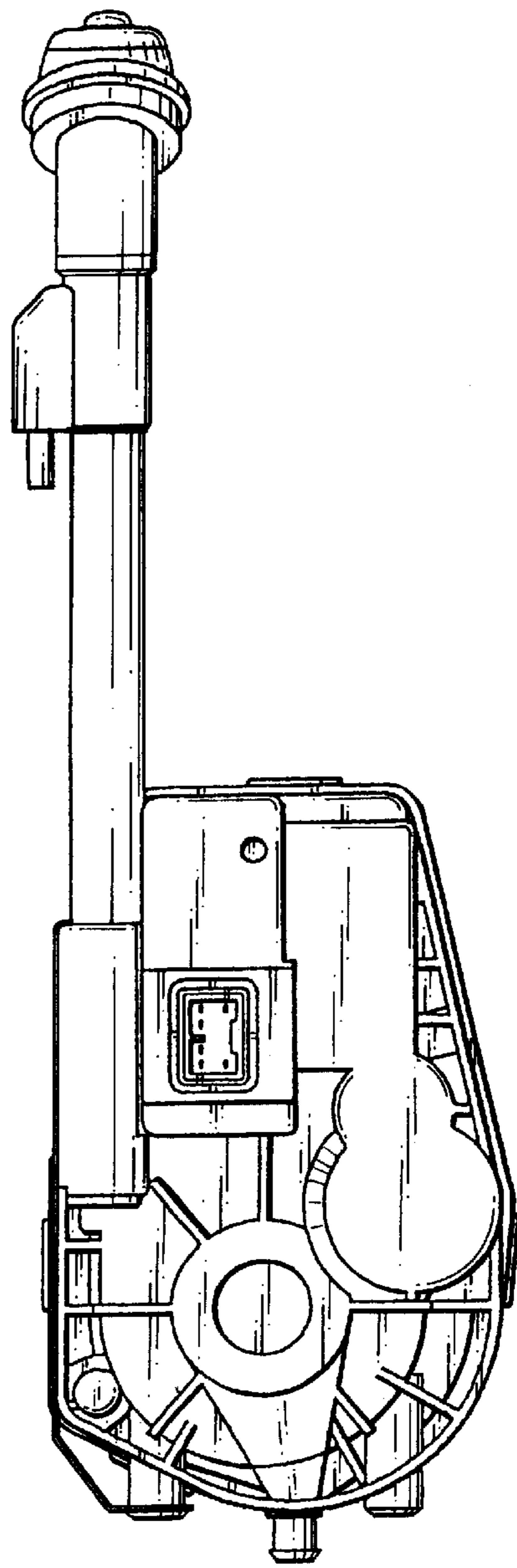

FIG. 3

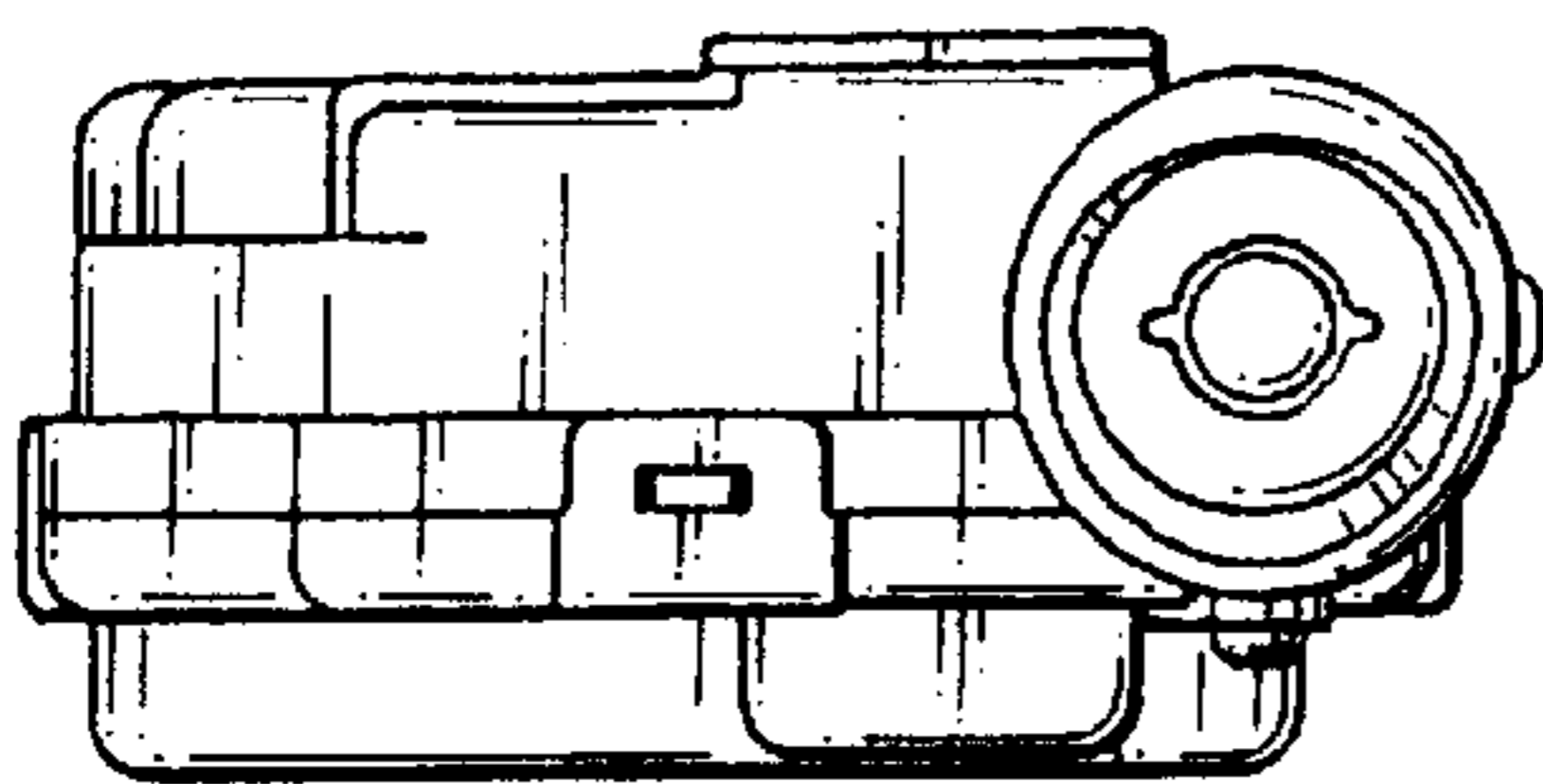

FIG. 4

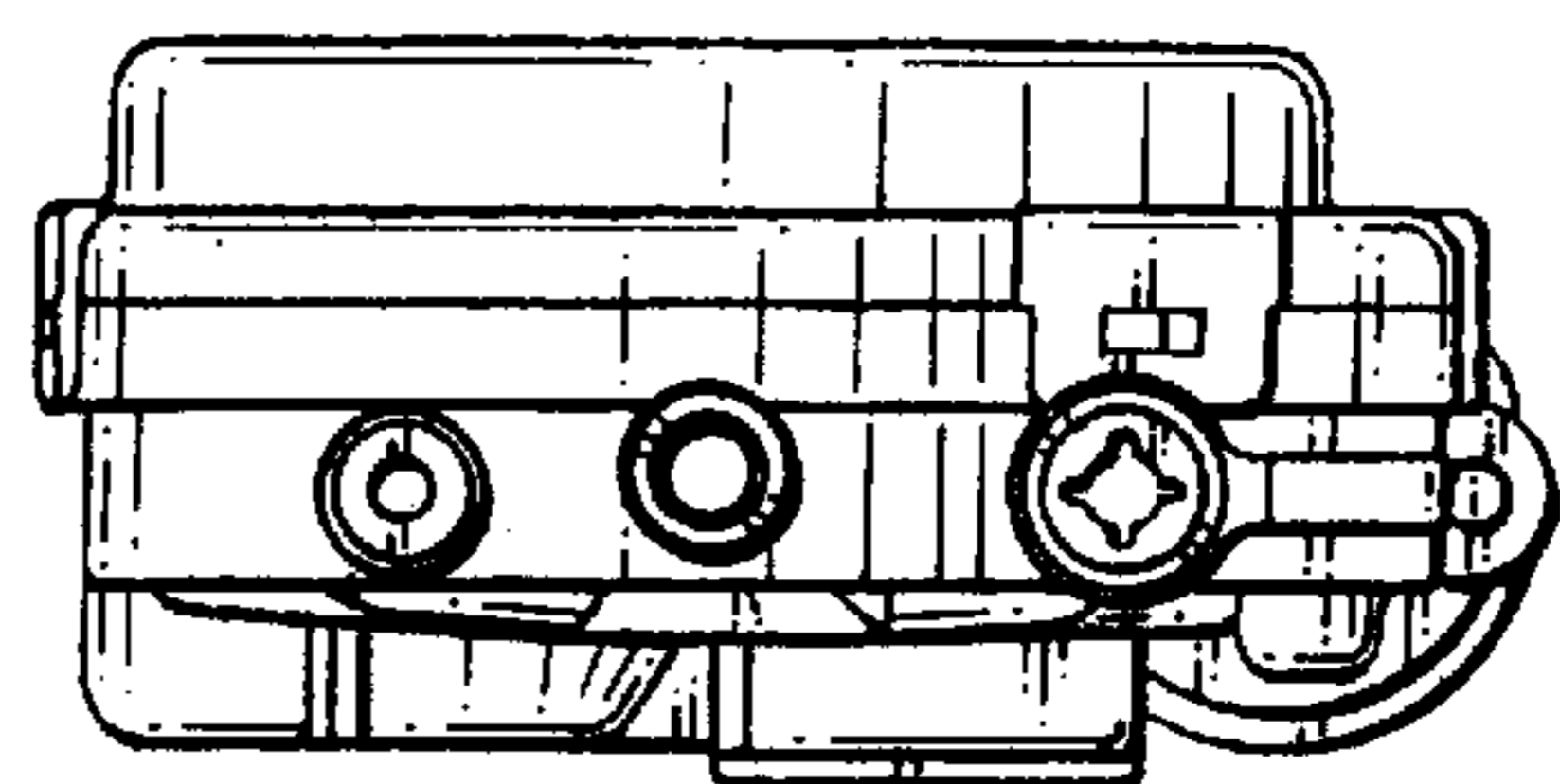

FIG. 5

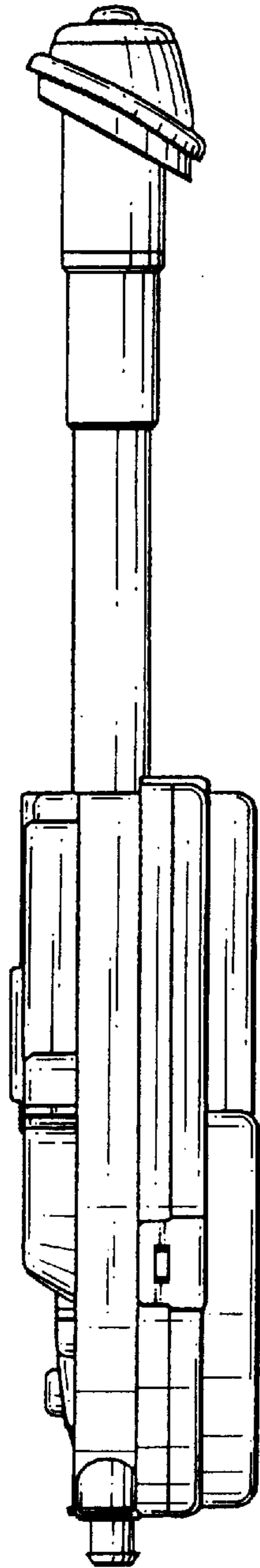

FIG. 6

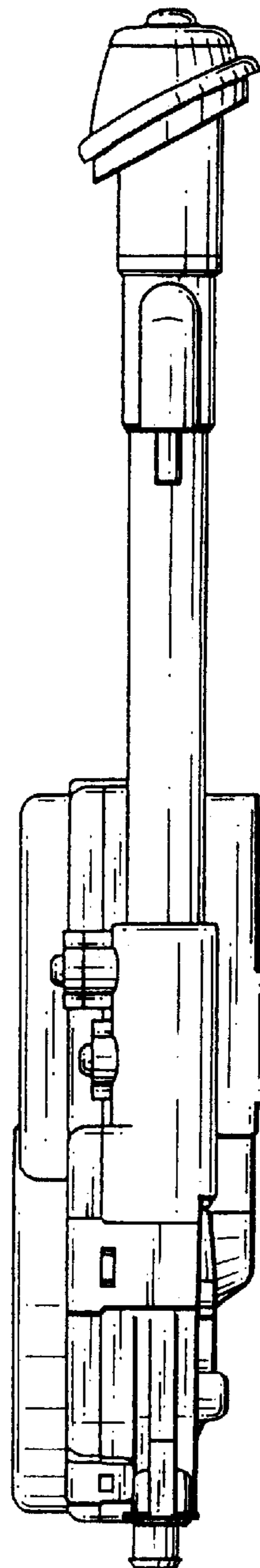

FIG. 7

