



US00D405412S

# United States Patent [19]

Gogan et al.

[11] Patent Number: **Des. 405,412**

[45] Date of Patent: **\*\*Feb. 9, 1999**

## [54] MOTORCYCLE LUGGAGE CARRIER

[75] Inventors: **Donald M. Gogan**, Brookfield;  
**Thomas G. Parsons**, Dousman, both of Wis.

[73] Assignee: **Harley-Davidson Motor Company**, Milwaukee, Wis.

[\*\*] Term: **14 Years**

[21] Appl. No.: **57,407**

[22] Filed: **Jul. 24, 1996**

### Related U.S. Application Data

[63] Continuation-in-part of Ser. No. 41,645, Jul. 20, 1995, abandoned.

[51] **LOC (6) Cl.** ..... **12-16**

[52] **U.S. Cl.** ..... **D12/407**

[58] **Field of Search** ..... D12/407; 224/412, 224/415, 423, 924

### [56] References Cited

#### U.S. PATENT DOCUMENTS

D. 203,960	3/1966	Stone	.....	D12/407
D. 208,895	10/1967	Lahti	.....	D12/407
D. 230,965	3/1974	Heltzen	.....	D12/407
D. 244,928	7/1977	Oakes	.....	D12/407
D. 255,561	6/1980	Pold et al.	.....	D12/407
D. 276,331	11/1984	Haiman et al.	.....	D12/407
D. 374,422	10/1996	Gogan et al.	.....	D12/407
4,032,189	6/1977	Benavente et al.	.....	297/352
4,993,731	2/1991	Fuller	.....	280/202

## OTHER PUBLICATIONS

Custom Chrome 1994 Catalog, pp. 623-624.  
V-twin 1993 Catalog, p. 511.  
Harley-Davidson 1992 Accessories Catalog.  
Harley-Davidson 1993 Accessories Catalog, p. 20.  
Harley-Davidson 1995 Parts and Accessories Catalog, pp. 41, 63, 73 and 82.  
"Sissy Bars, Racks & Bags," from *Hot Road Bikes*, pp. 67-68, Jan. 1996.

*Primary Examiner*—Melody N. Brown  
*Attorney, Agent, or Firm*—Michael, Best & Friedrich LLP

## [57] CLAIM

We claim the ornamental design for a motorcycle luggage carrier, as shown and described.

## DESCRIPTION

FIG. 1 is a right side view of a luggage rack embodying the present invention;  
FIG. 2 is a left side view of the luggage rack shown in FIG. 1;  
FIG. 3 is a top view of the luggage rack shown in FIG. 1;  
FIG. 4 is a front view of the luggage rack shown in FIG. 1; and,  
FIG. 5 is a rear view of the luggage rack shown in FIG. 1. The bottom view of the luggage rack is not visible in its normal or intended use because it is substantially obscured by the motorcycle. Therefore, the bottom view is not a matter of ornamental concern, and has been omitted from the drawings.

**1 Claim, 2 Drawing Sheets**

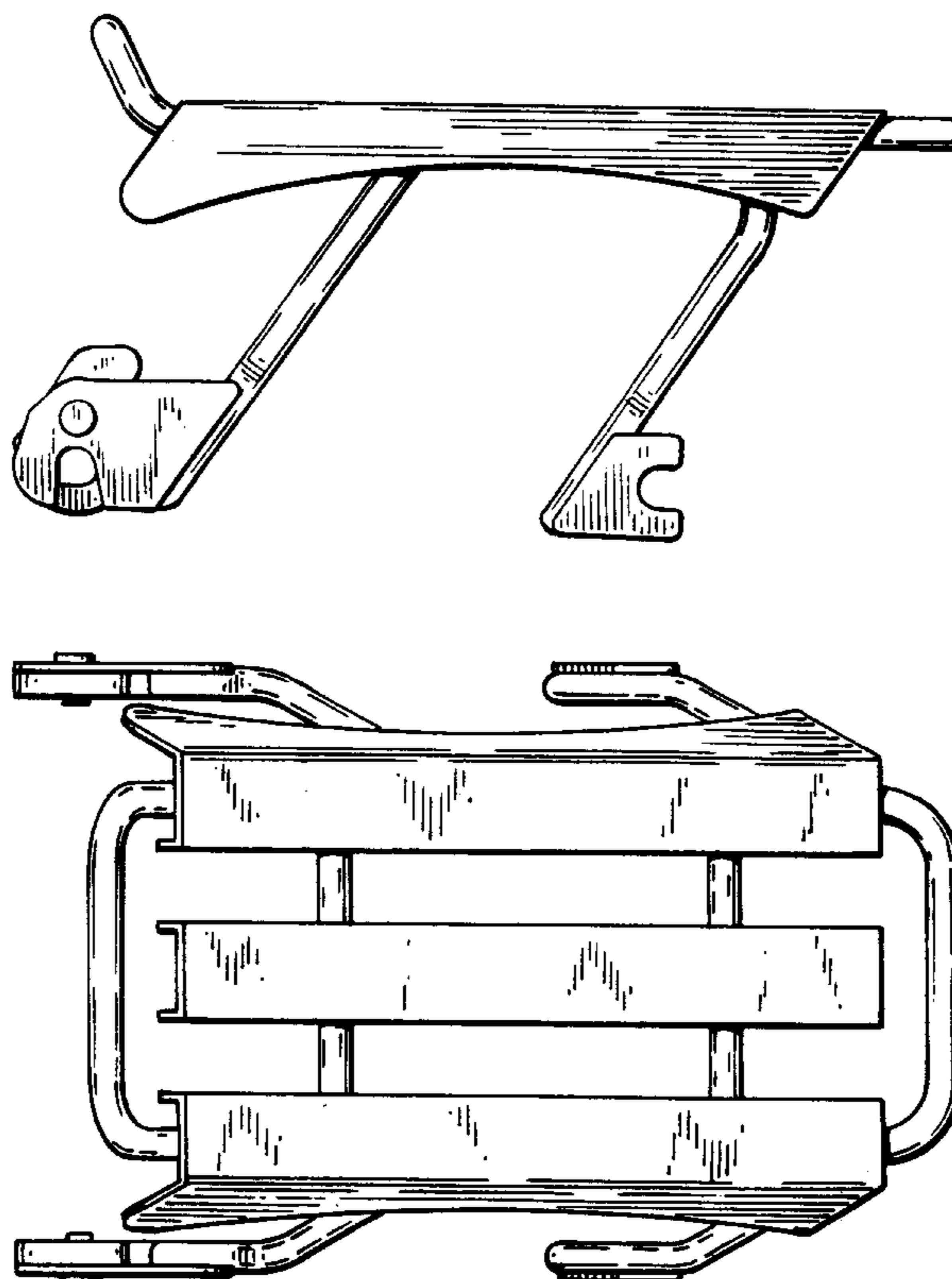

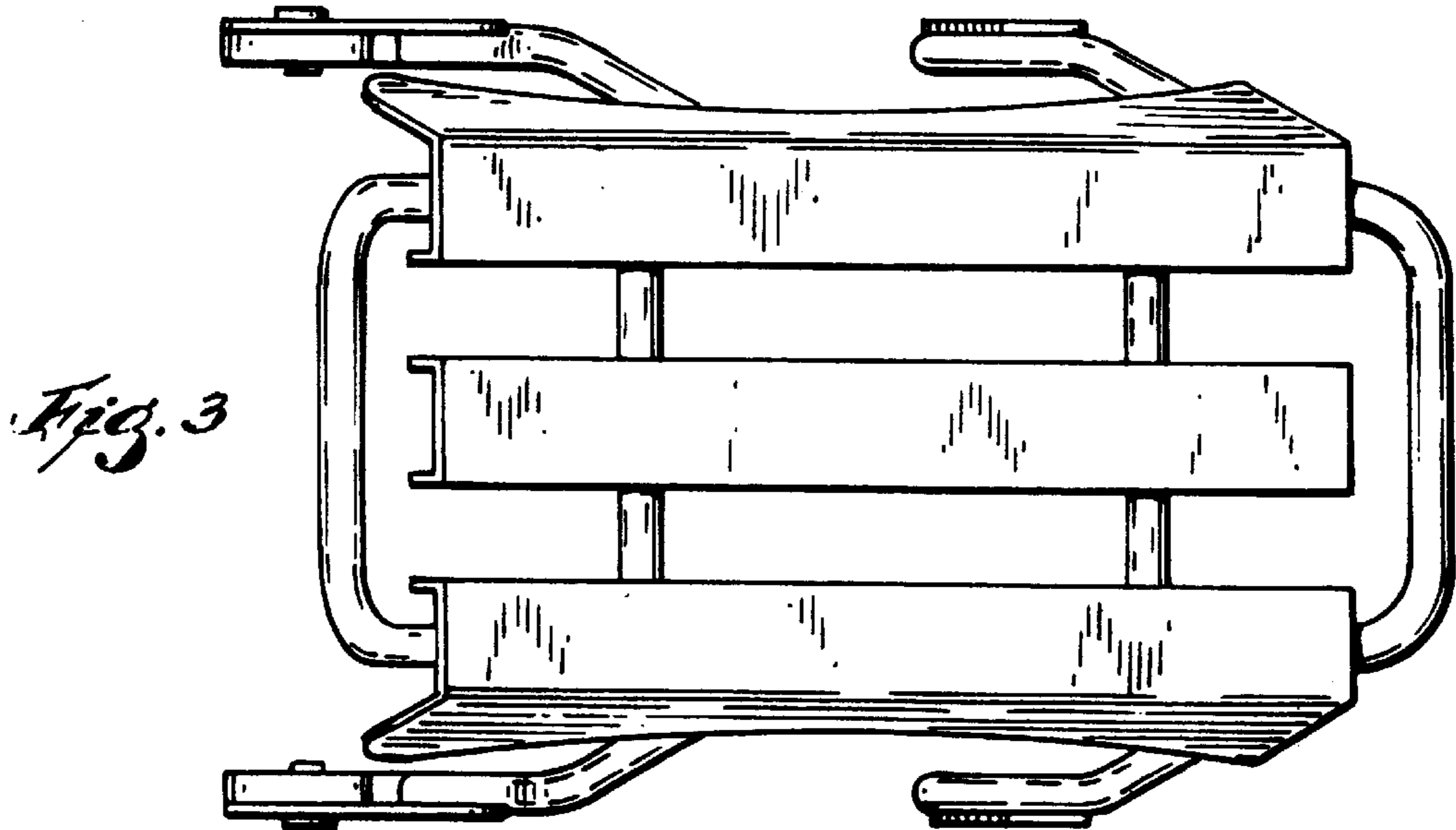
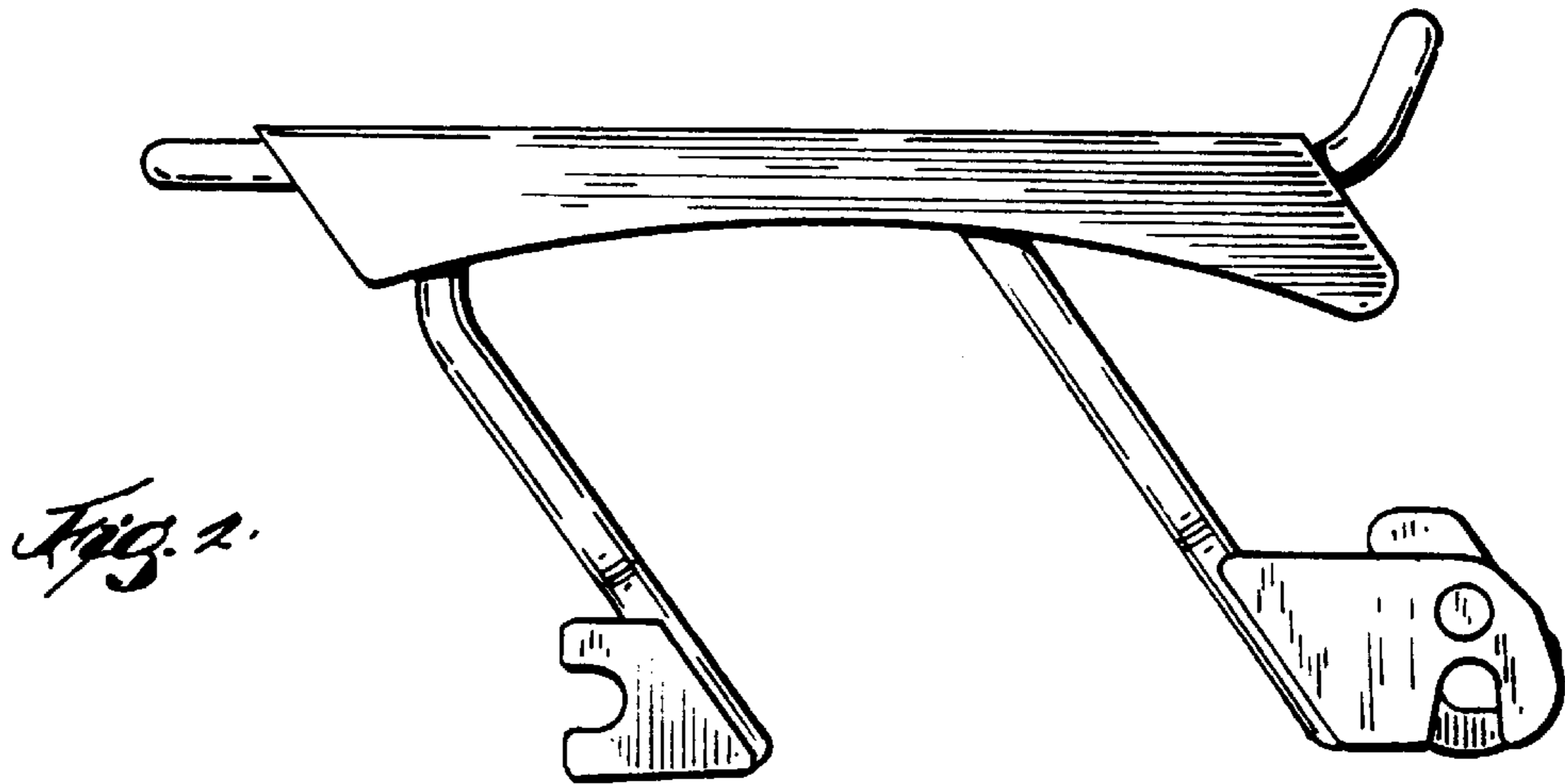
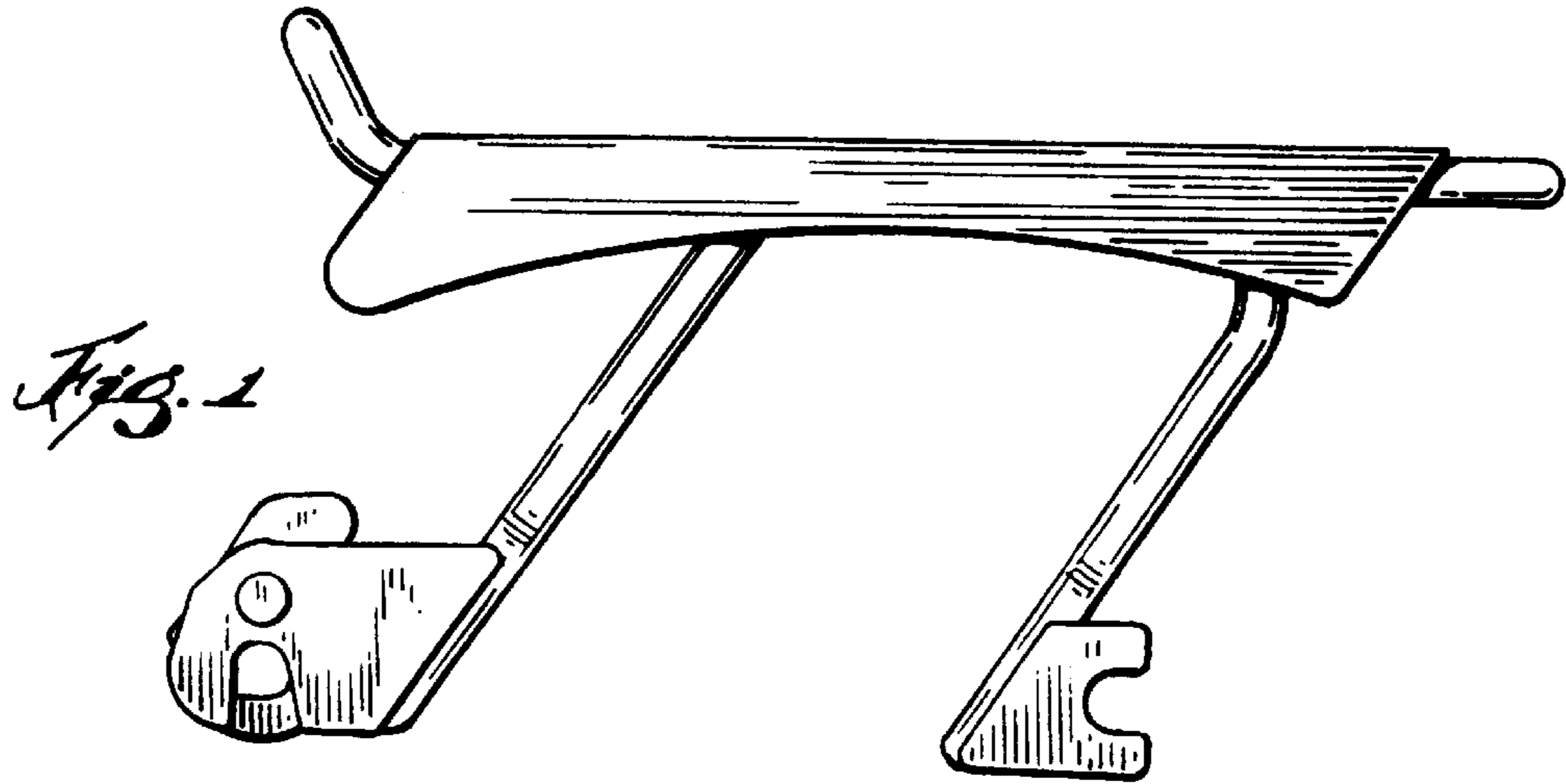

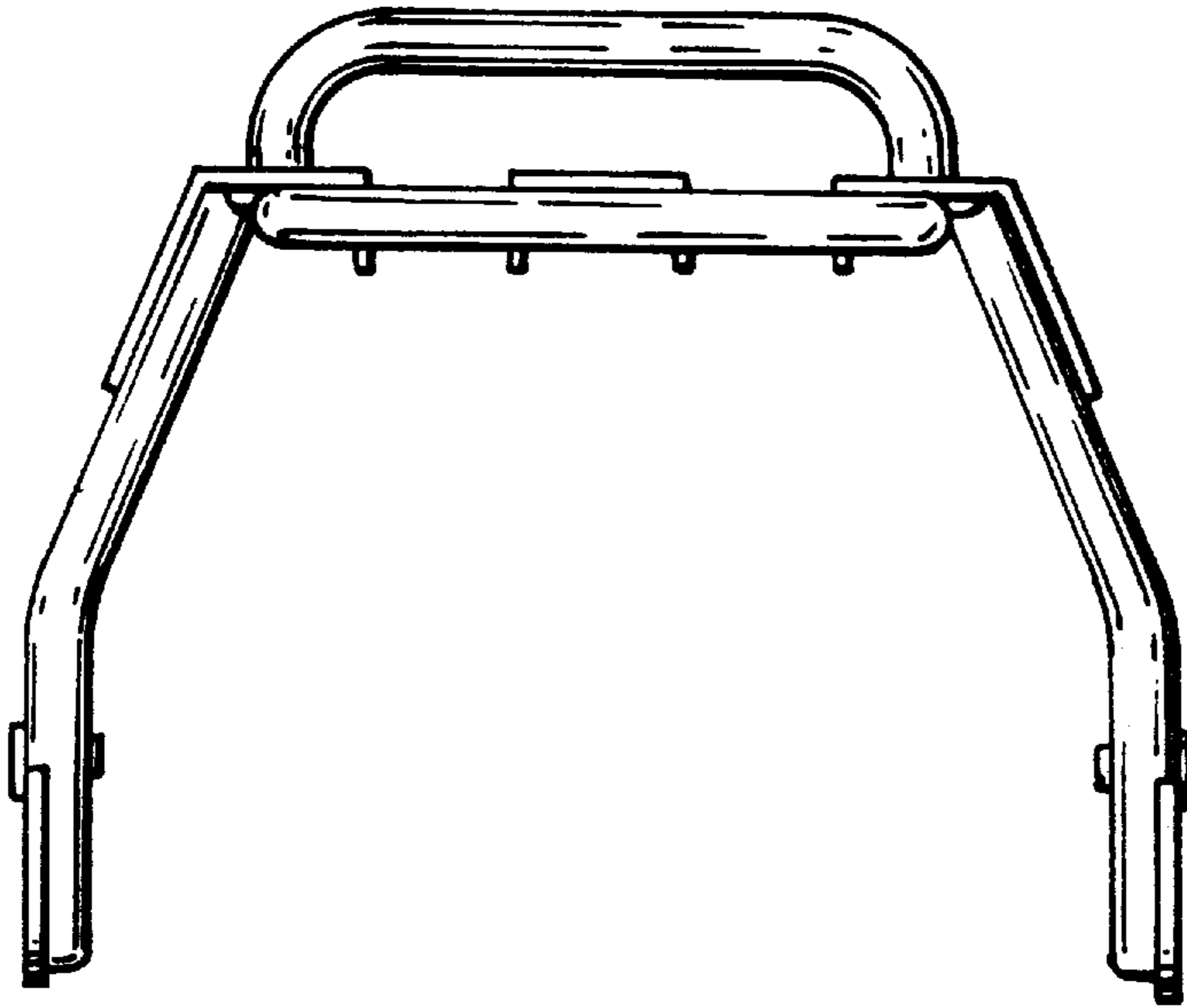

*Fig. 4*

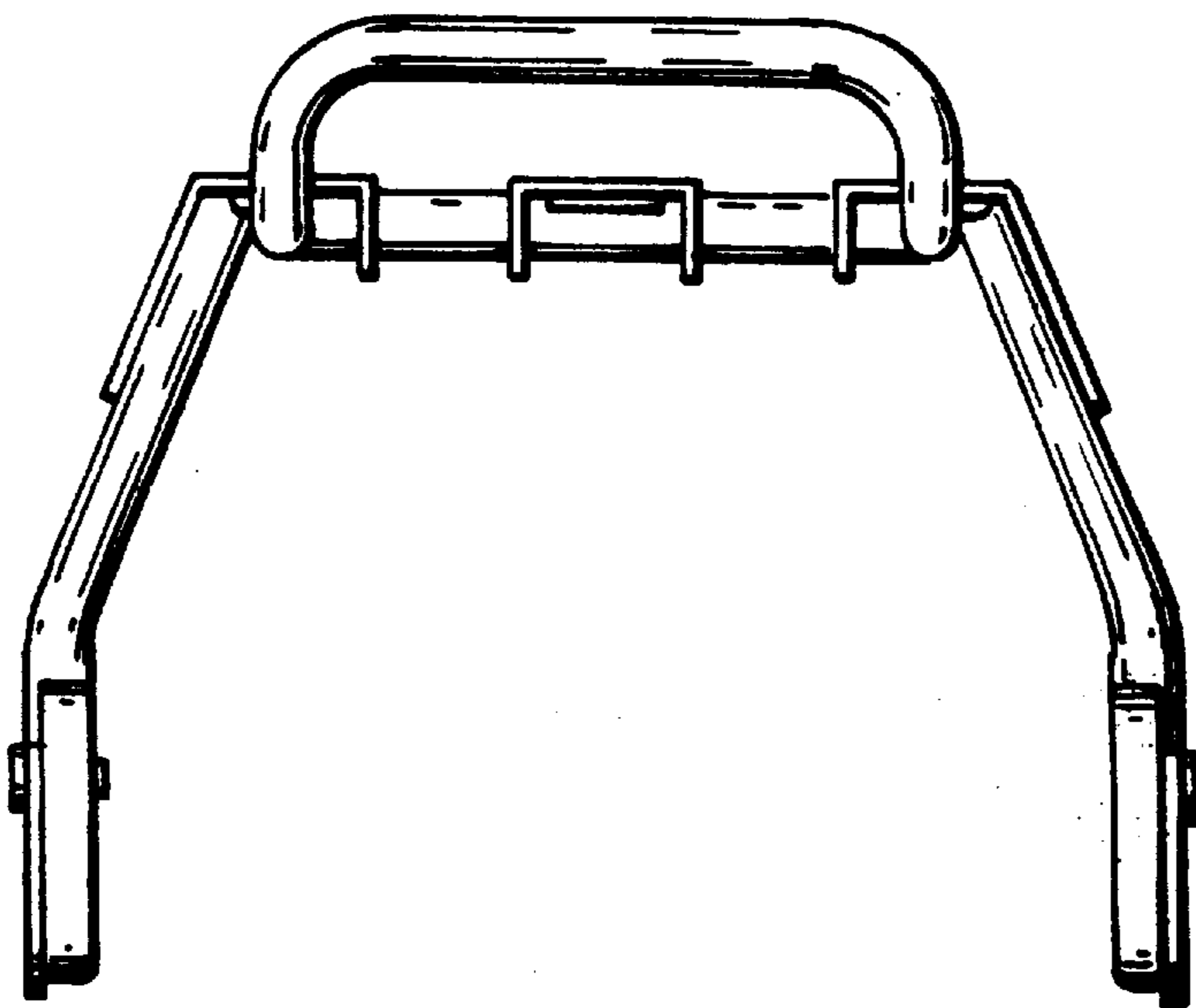

*Fig. 5*