



US00D405393S

United States Patent [19]
Stahel

[11] **Patent Number: Des. 405,393**

[45] **Date of Patent: **Feb. 9, 1999**

[54] **MOTORCYCLE FOOT PEG**

[75] Inventor: **Alwin J. Stahel**, New Brighton, Minn.

[73] Assignee: **KuryAkyn Holdings, Inc.**, Somerset, Wis.

[**] Term: **14 Years**

[21] Appl. No.: **84,992**

[22] Filed: **Feb. 27, 1998**

[51] **LOC (6) Cl.** **12-10**

[52] **U.S. Cl.** **D12/114**

[58] **Field of Search** D12/114, 120,
D12/125; 280/288.4, 291, 293; 180/219;
74/564, 594.4, 594.6

[56] **References Cited**

U.S. PATENT DOCUMENTS

D. 282,154	1/1986	Cruze et al.	D12/114
D. 291,293	8/1987	Downing et al.	D12/125
D. 319,037	8/1991	Hoeptner, III	D12/114
D. 378,667	4/1997	Ortega	D12/114

Primary Examiner—Melody N. Brown
Attorney, Agent, or Firm—Hessian & McKasy, P.A.; Glen E. Schumann

[57] **CLAIM**

A new and ornamental design for a motorcycle foot peg, as shown and described.

DESCRIPTION

FIG. 1 is a view in perspective as seen from the top, side and one end of a “motorcycle foot peg” showing our new design; FIG. 2 is an end elevation as seen from the end shown in FIG. 1;

FIG. 3 is an end elevation as seen from the end opposite that shown in FIG. 2;

FIG. 4 is a view in top plan;

FIG. 5 is a side elevation as seen from bottom to top of FIG. 4;

FIG. 6 is a side elevation as seen from the side opposite that shown in FIG. 5; and,

FIG. 7 is a view in bottom plan.

1 Claim, 3 Drawing Sheets

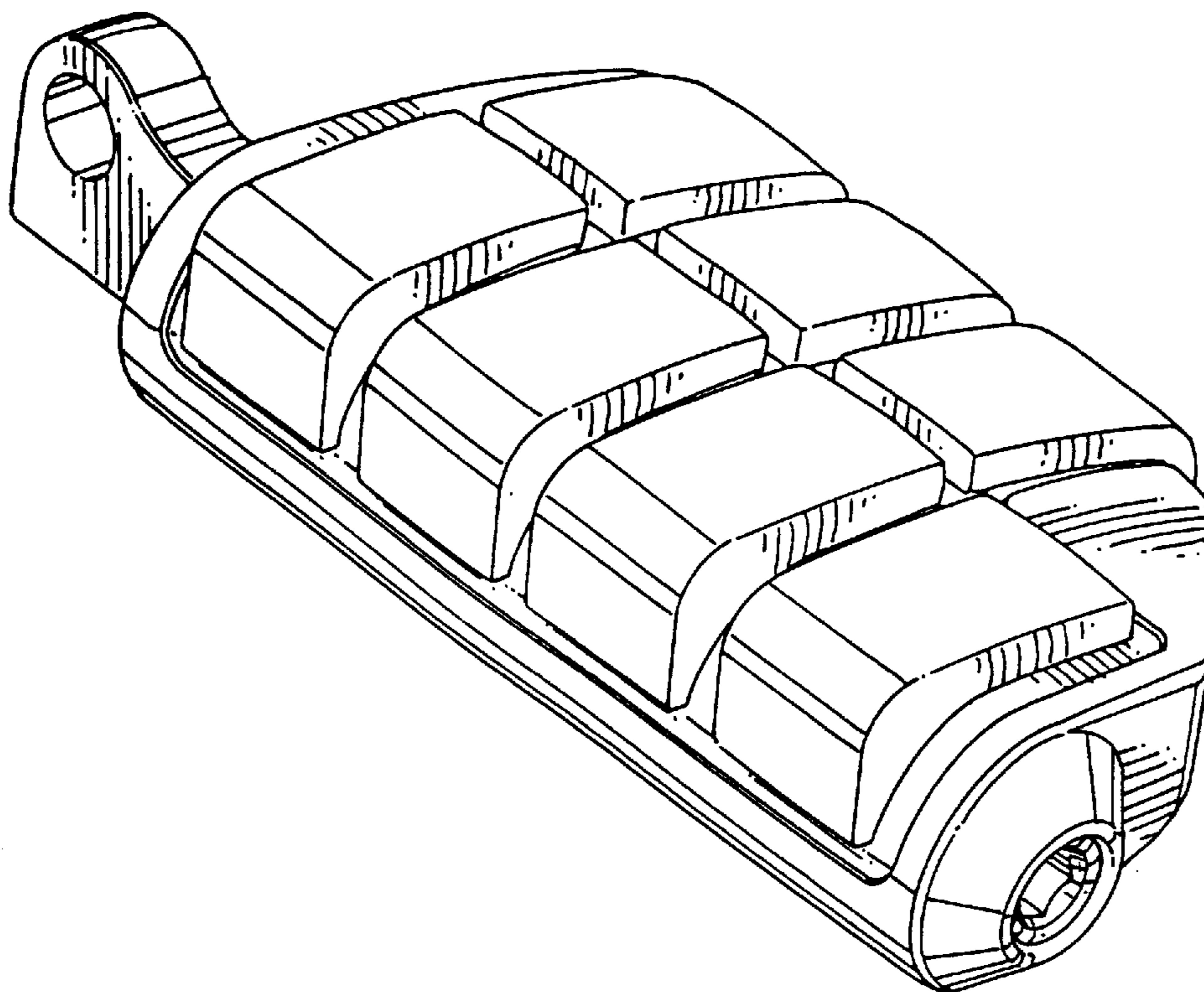

FIG. 1

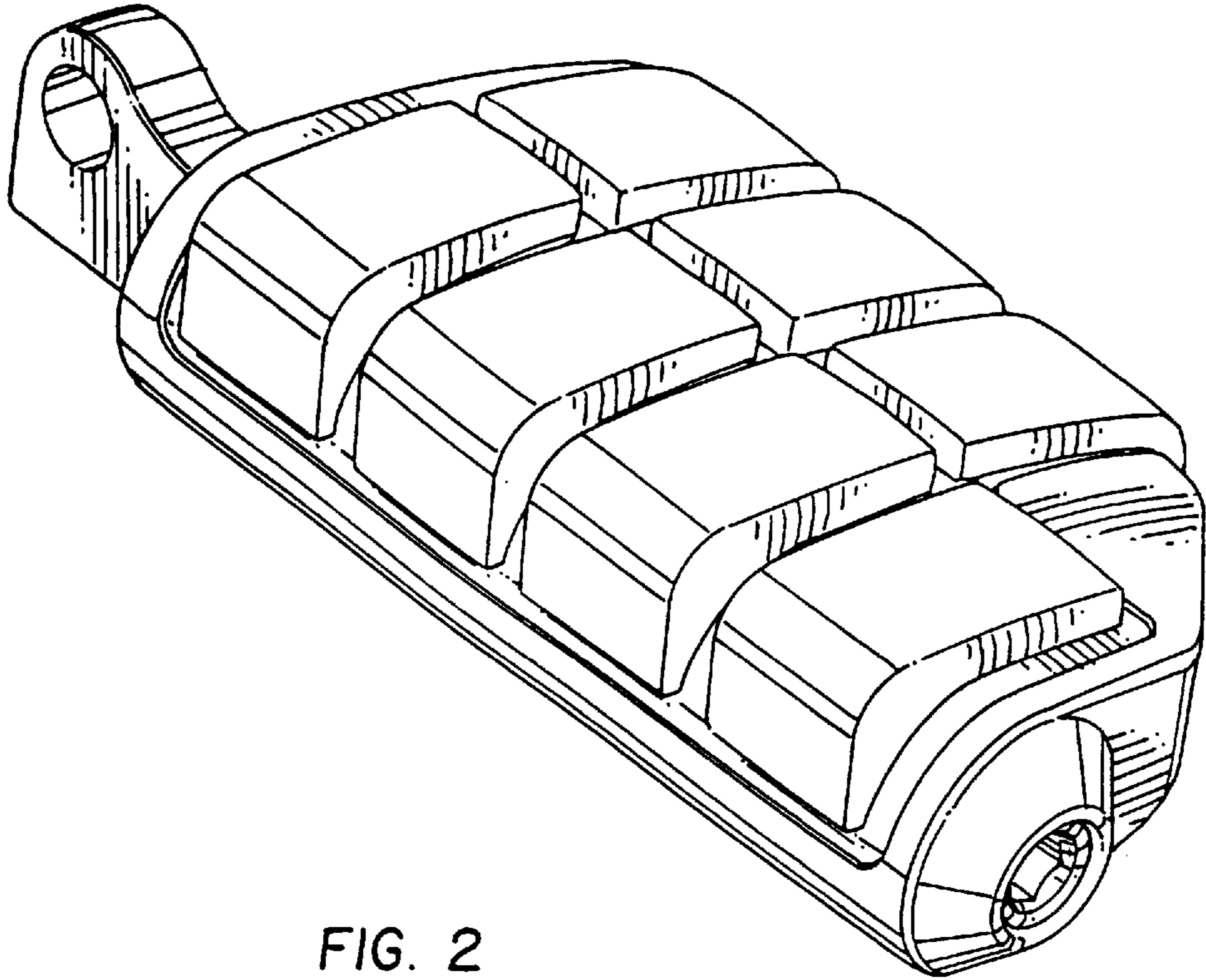

FIG. 2

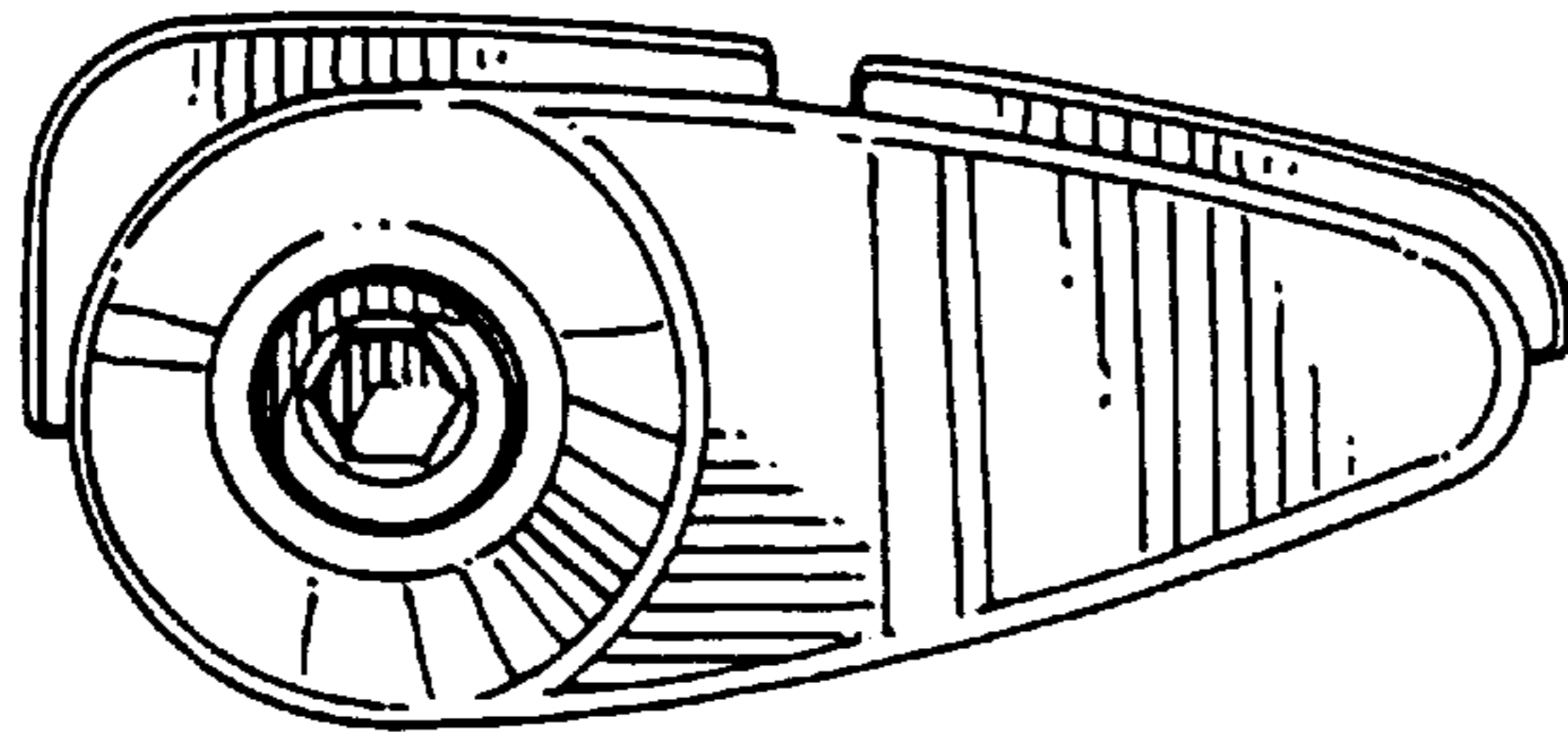

FIG. 3

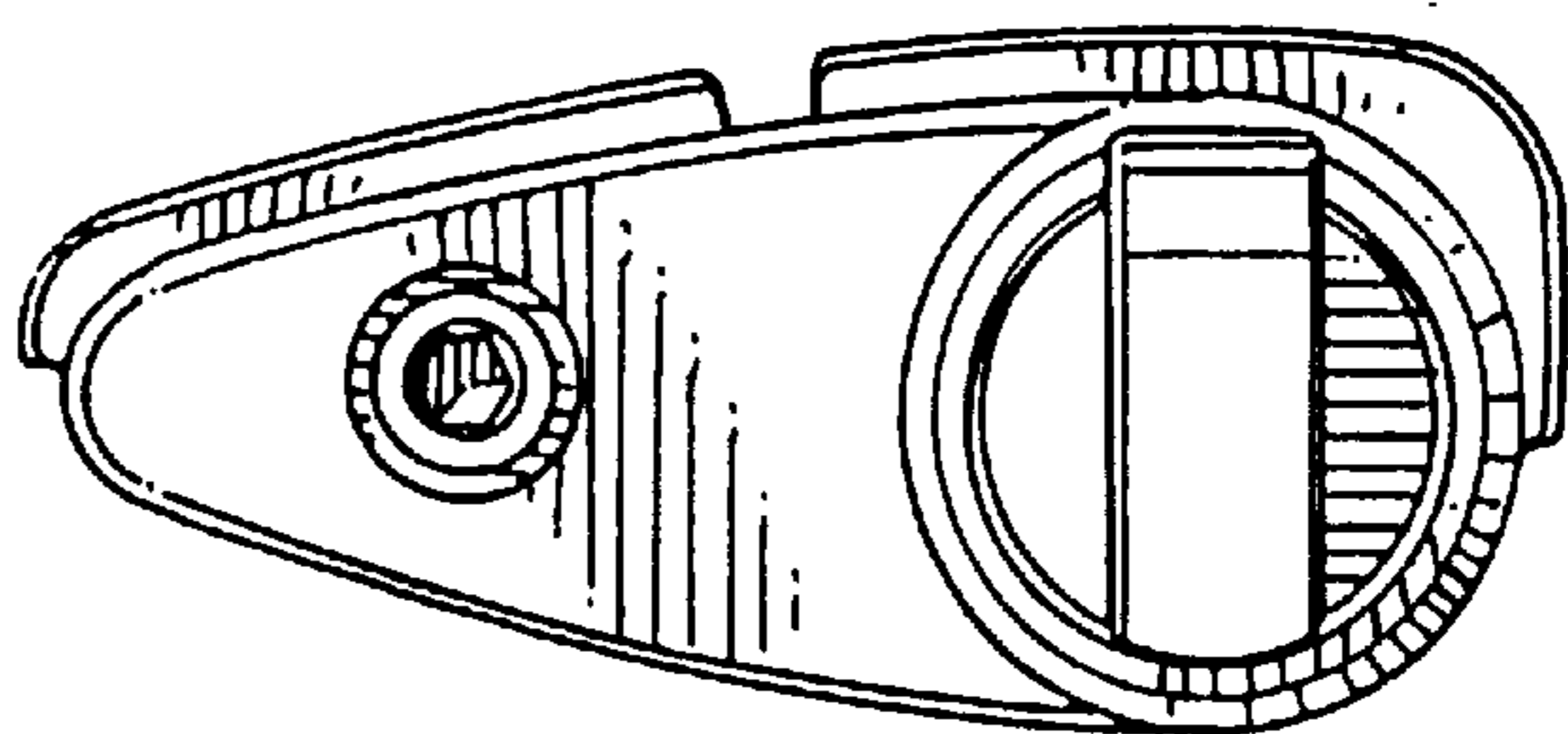

FIG. 4

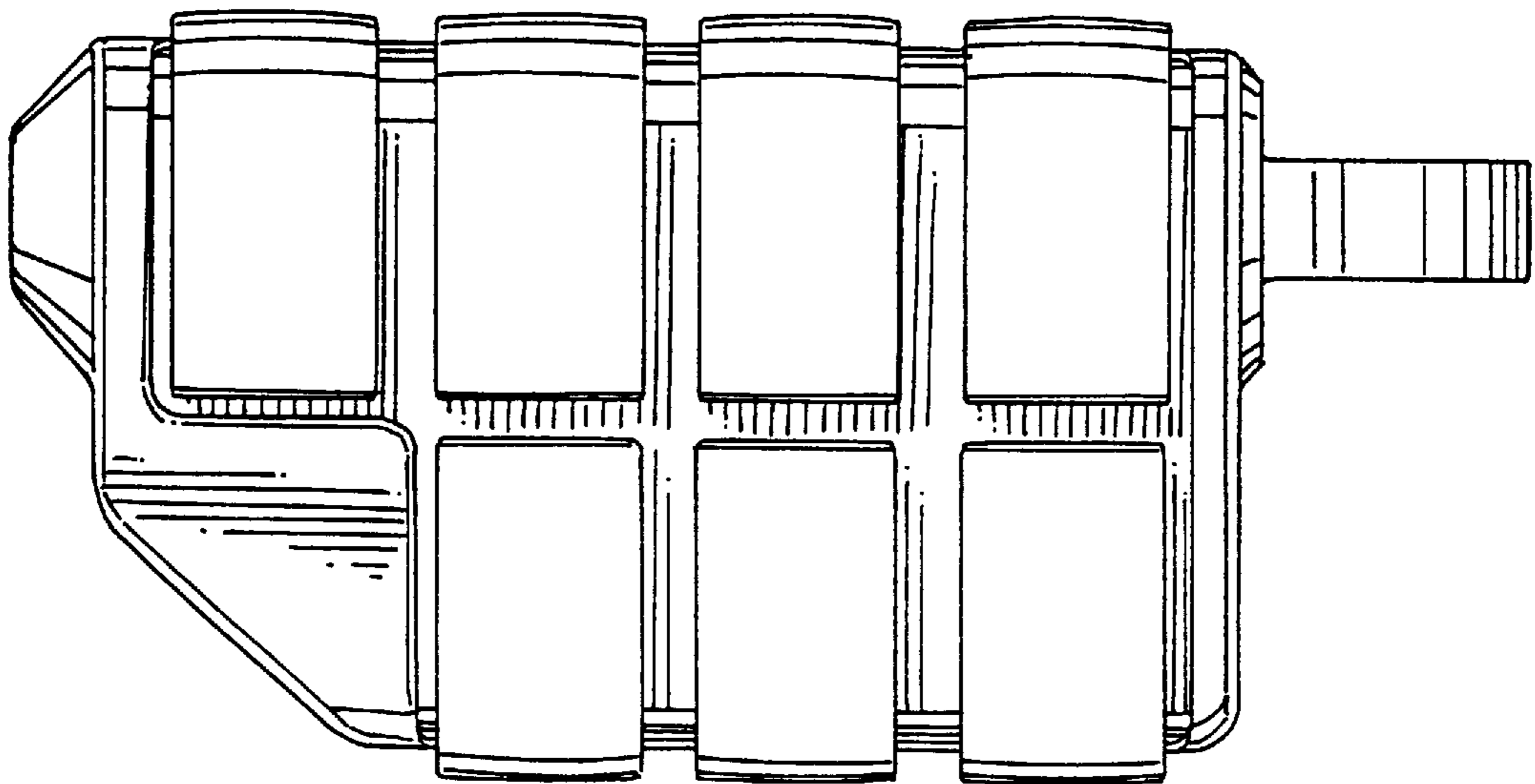

FIG. 5

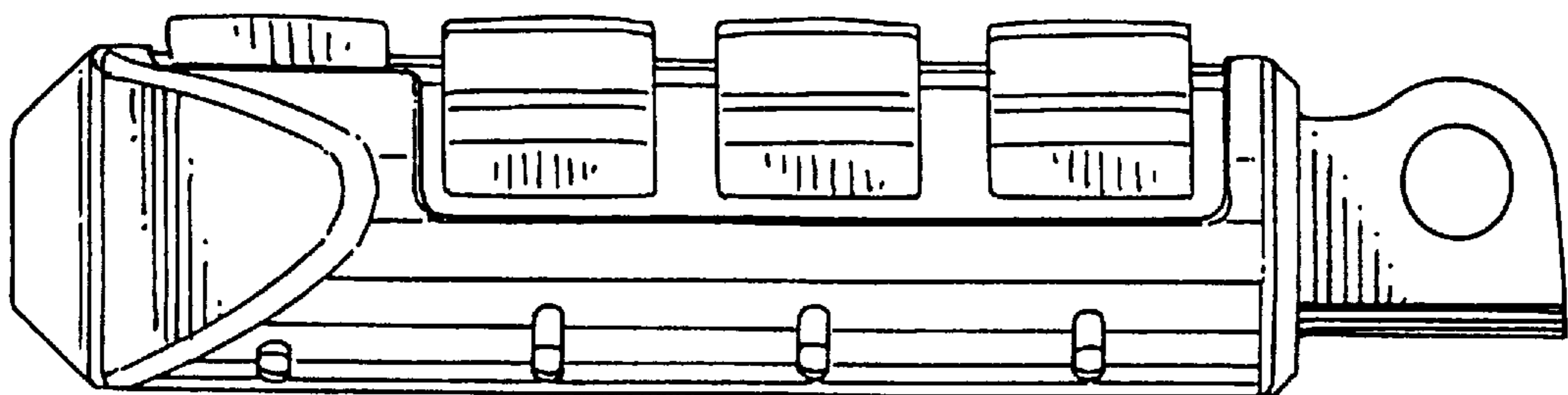

FIG. 6

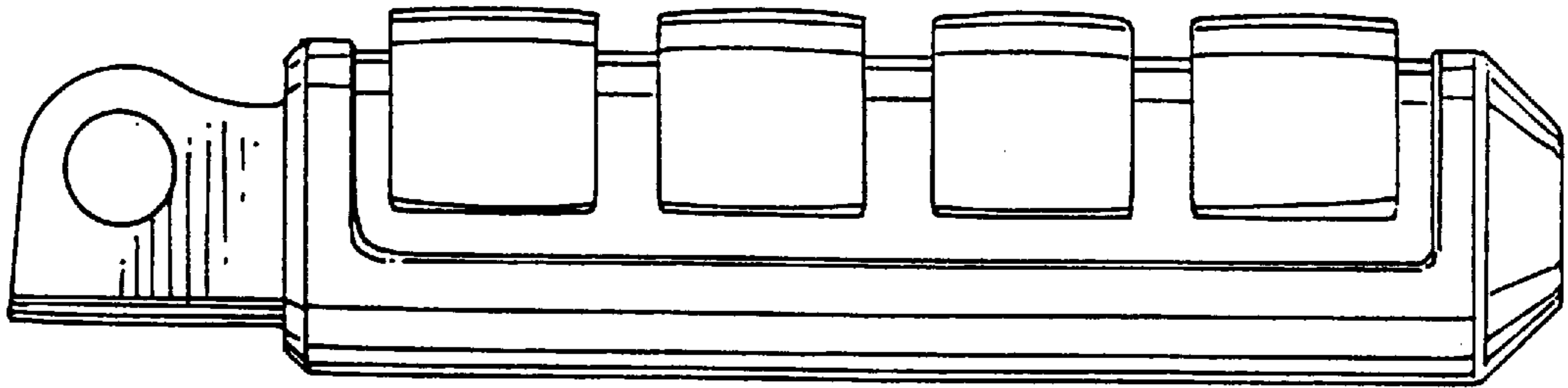

FIG. 7

